

Specification Sheet ICE 823B Excavator Mounted Vibratory Hammer

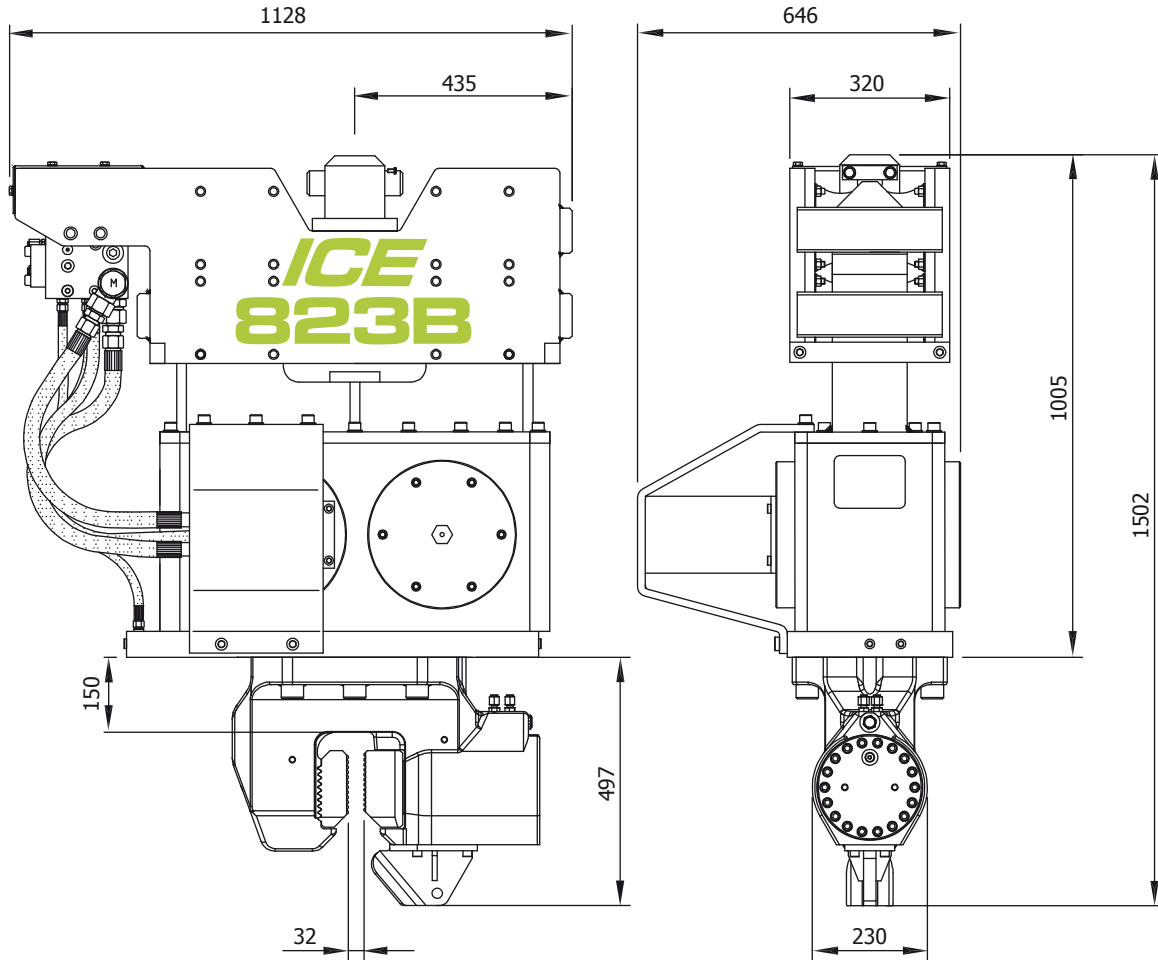

Specifications

823B

| | | | | |
|-------------------------------------|---------|-------|----------------------------|--------|
| Eccentric moment | 8 | kgm | Clamps: | |
| Max. centrifugal force | 464 | kN | Sheet pile clamp | 60TU |
| Max. frequency | 2300 | rpm | Transport weight per piece | 250 kg |
| Max. amplitude excluding 60TU | 23.2 | mm | | |
| Max. amplitude including 60TU | 17 | mm | | |
| Max. static line-pull | 120 | kN | | |
| Max hydraulic power | 108/147 | kW/HP | | |
| Max. operating pressure | 350 | bar | | |
| Max. oil flow | 185 | l/min | | |
| Forced lubrication | no | | | |
| Dynamic weight excluding 60TU | 690 | kg | | |
| Dynamic weight including 60TU | 940 | kg | | |
| Total weight excluding 60TU & hoses | 1060 | kg | | |

