

Specifications :

ICE 150NF

Eccentric moment	150 kgm	Clamps:	
Max. centrifugal force	3224 kN	Double clamps	200TC
Max. frequency	1400 rpm	Transport weight per piece	1350 kg
Max. amplitude excl. PPK 200TC (2x)	26.3 mm		
Max. amplitude incl. PPK 200TC (2x)	21.3 mm		
Max. static line-pull	1260 kN		
Max. operating pressure	350 bar	Powerpack:	
Max. oil flow	1293 l/min	Model	1400 series
Forced lubrication	yes		
Dynamic weight excl. PPK 200TC (2x)	11400 kg	Hose set:	
Dynamic weight incl. PPK 200TC (2x)	14100 kg	Length	60 m
Total weight excl. PPK 200TC (2x) & hoses	17780 kg	Transport weight (±)	1640 kg

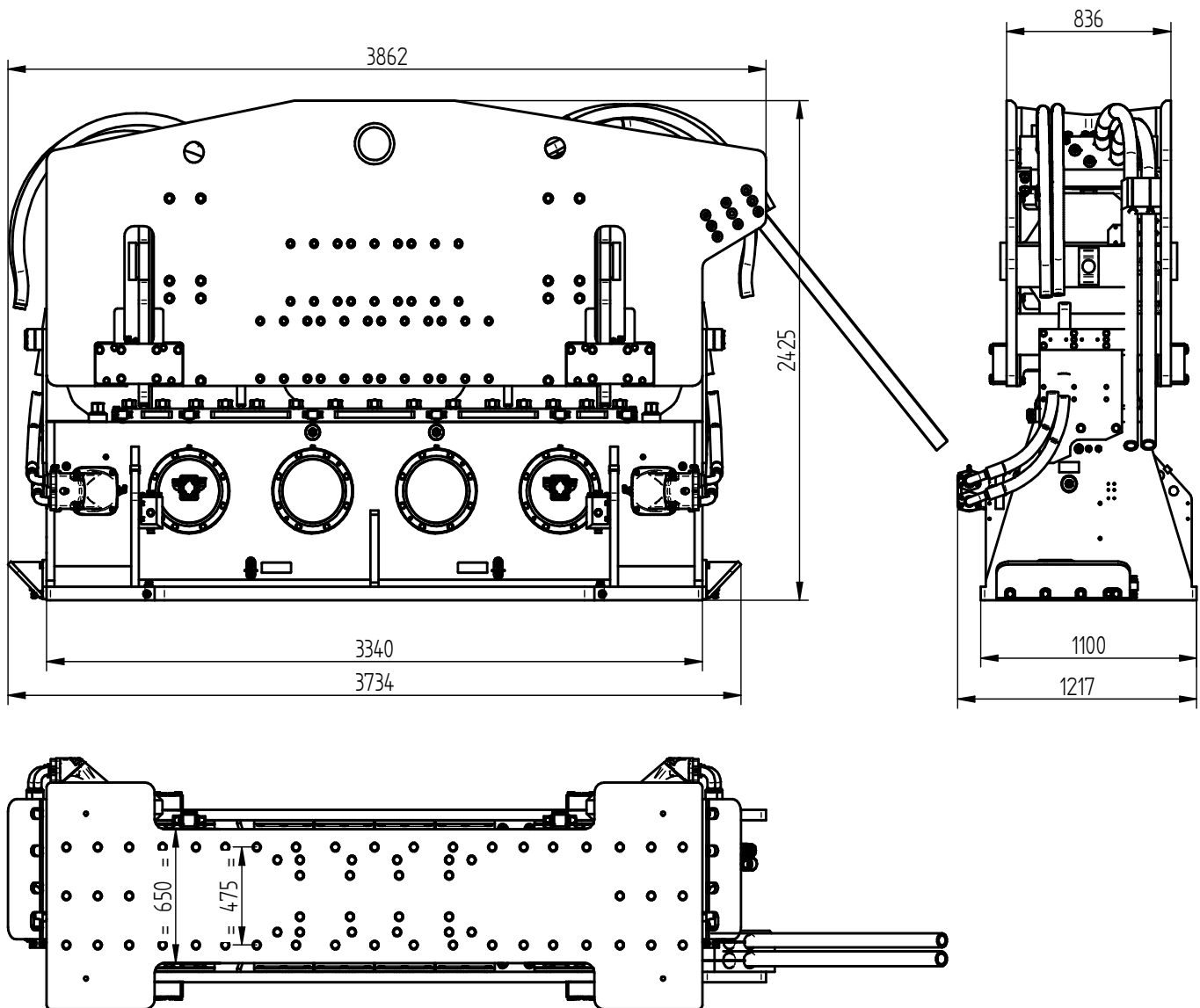

Technische Daten :

ICE 150NF

Statisches Moment	150 kgm	Klemmzange:	
Max. Fliehkraft	3224 kN	Rohrklemmzange	200TC
Max. Drehzahl	1400 rpm	Transportgew. pro Stück	1350 kg
Max. Amplitude ohne PPK 200TC (2x)	26.3 mm		
Max. Amplitude mit PPK 200TC (2x)	21.3 mm		
Max. Statische Zugkraft	1260 kN		
Max. Betriebsdruck	350 bar	Aggregat:	
Max. Fördermenge	1293 l/min	Modell	1400 series
Zwangsschmierung	ja		
Dyn. Gewicht ohne PPK 200TC (2x)	11400 kg	Schlauchsatz:	
Dyn. Gewicht mit PPK 200TC (2x)	14100 kg	Länge	60 m
Gesamtgew. ohne PPK 200TC (2x) & Schläuche	17780 kg	Transportgewicht (±)	1640 kg

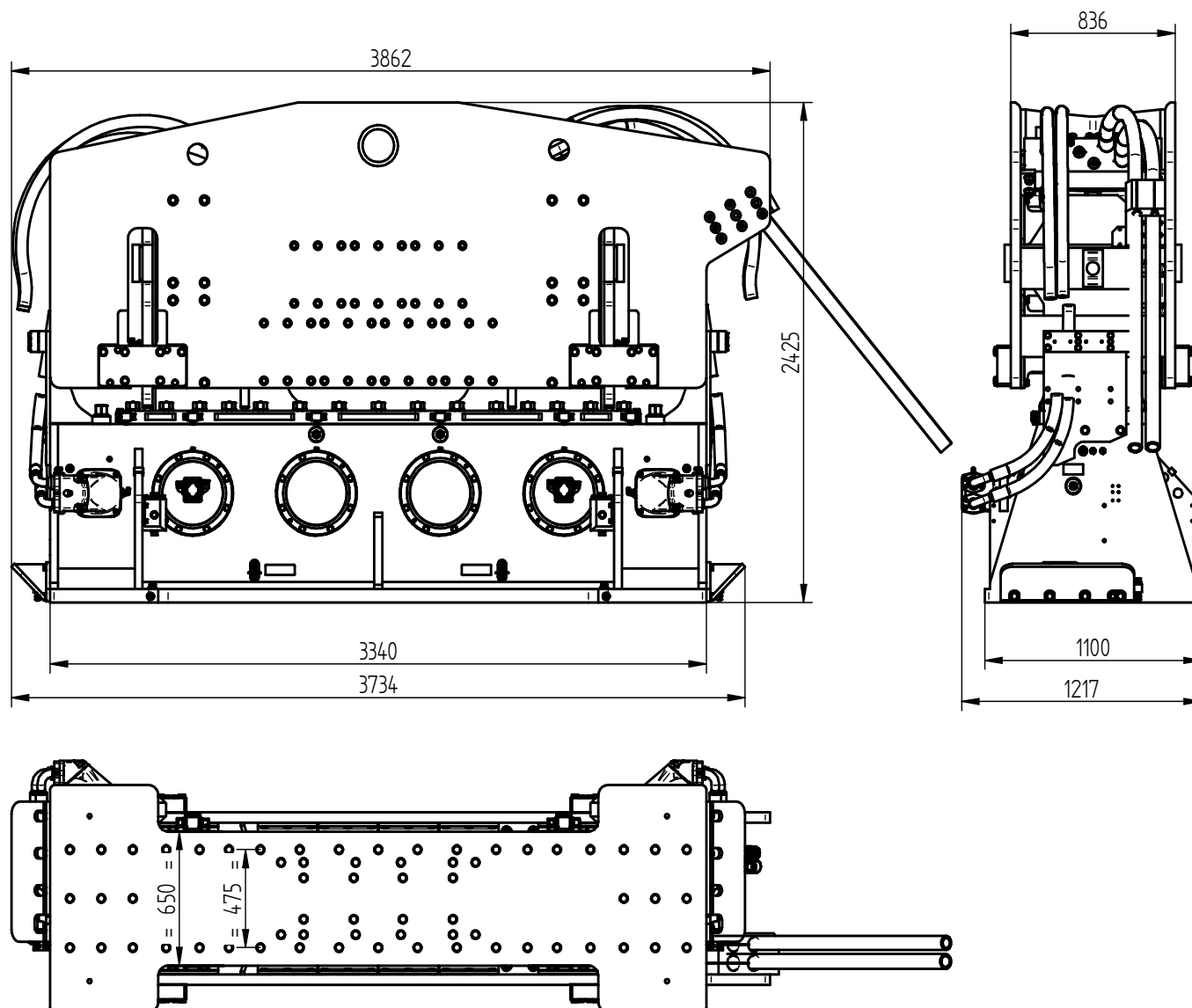

Spécifications

ICE 150NF

Moment excentrique	150 kgm	Pinces:	
Max. force centrifuge	3224 kN	Pince tube	200TC
Max. fréquence	1400 rpm	Poids de transport par pièce	1350 kg
Max. amplitude sans PPK 200TC (2x)	26.3 mm		
Max. amplitude avec PPK 200TC (2x)	21.3 mm		
Force de traction statique	1260 kN		
Pression de travail max.	350 bar	Groupe hydraulique:	
Débit d'huile max.	1293 l/min	Modèle	1400 series
Huile lubrifiante	oui		
Poids dynamique sans PPK 200TC (2x)	11400 kg	Jeu de tuyau:	
Poids dynamique avec PPK 200TC (2x)	14100 kg	Longueur	60 m
Poids total sans PPK 200TC (2x) & tuyaux	17780 kg	Poids de transport (±)	1640 kg

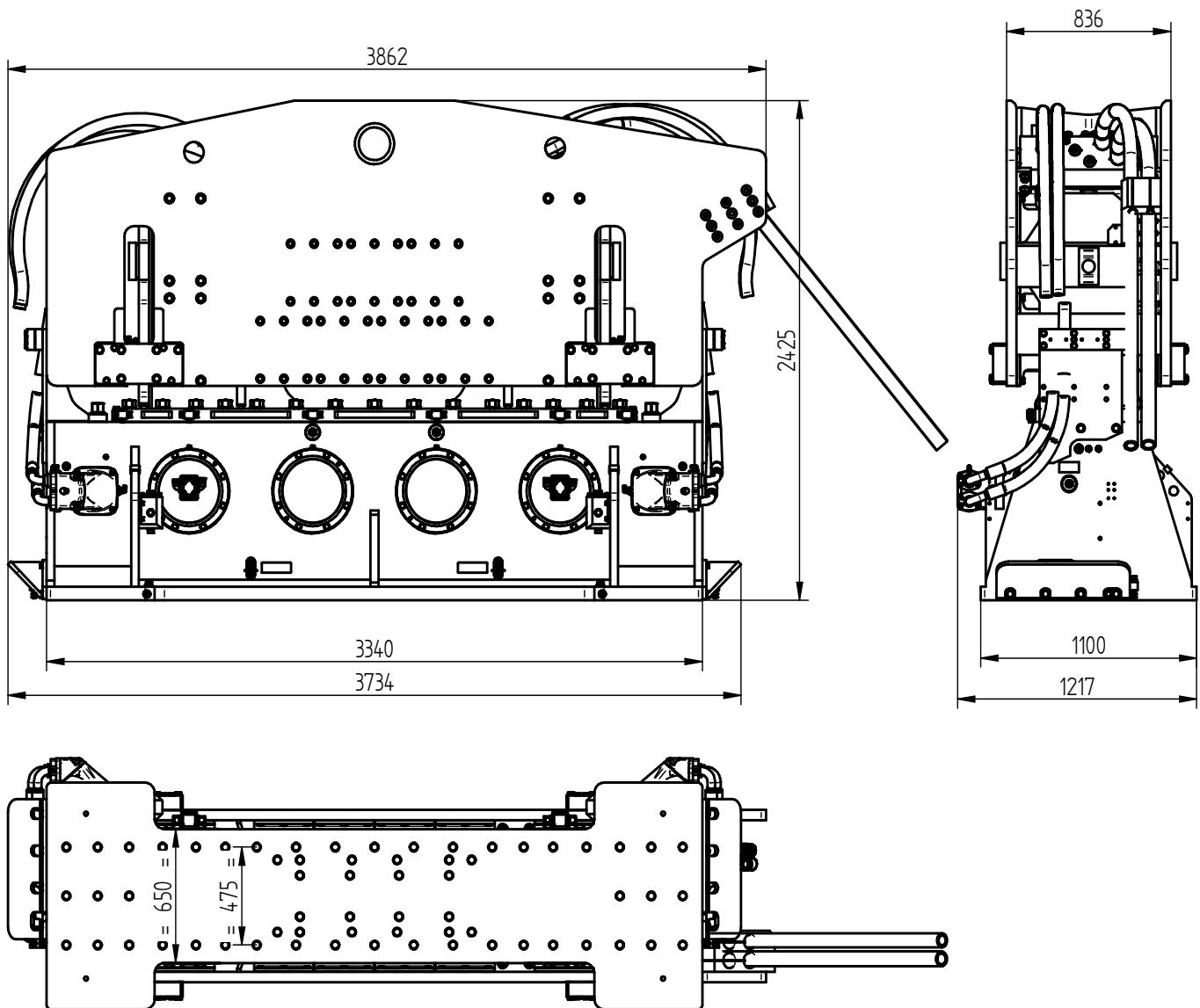
Specificaties
ICE 150NF

Excentrisch moment	150 kgm	Klemmen:	
Max. centrifugaalkracht	3224 kN	Pijpenklem	200TC
Max. toerental	1400 rpm	Transportgewicht per klem	1350 kg
Max. amplitude excl. PPK 200TC (2x)	26.3 mm		
Max. amplitude incl. PPK 200TC (2x)	21.3 mm		
Max. statische trekkracht	1260 kN		
Max. werkdruk	350 bar	Aggregaat:	
Max. oliedoorstroming	1293 l/min	Model	1400 series
Geforceerde smering	ja		
Dynamisch gewicht excl. PPK 200TC (2x)	11400 kg	Slangenset:	
Dynamisch gewicht incl. PPK 200TC (2x)	14100 kg	Lengte	60 m
Totaalgewicht excl. PPK 200TC (2x) & slangen	17780 kg	Transportgewicht (±)	1640 kg

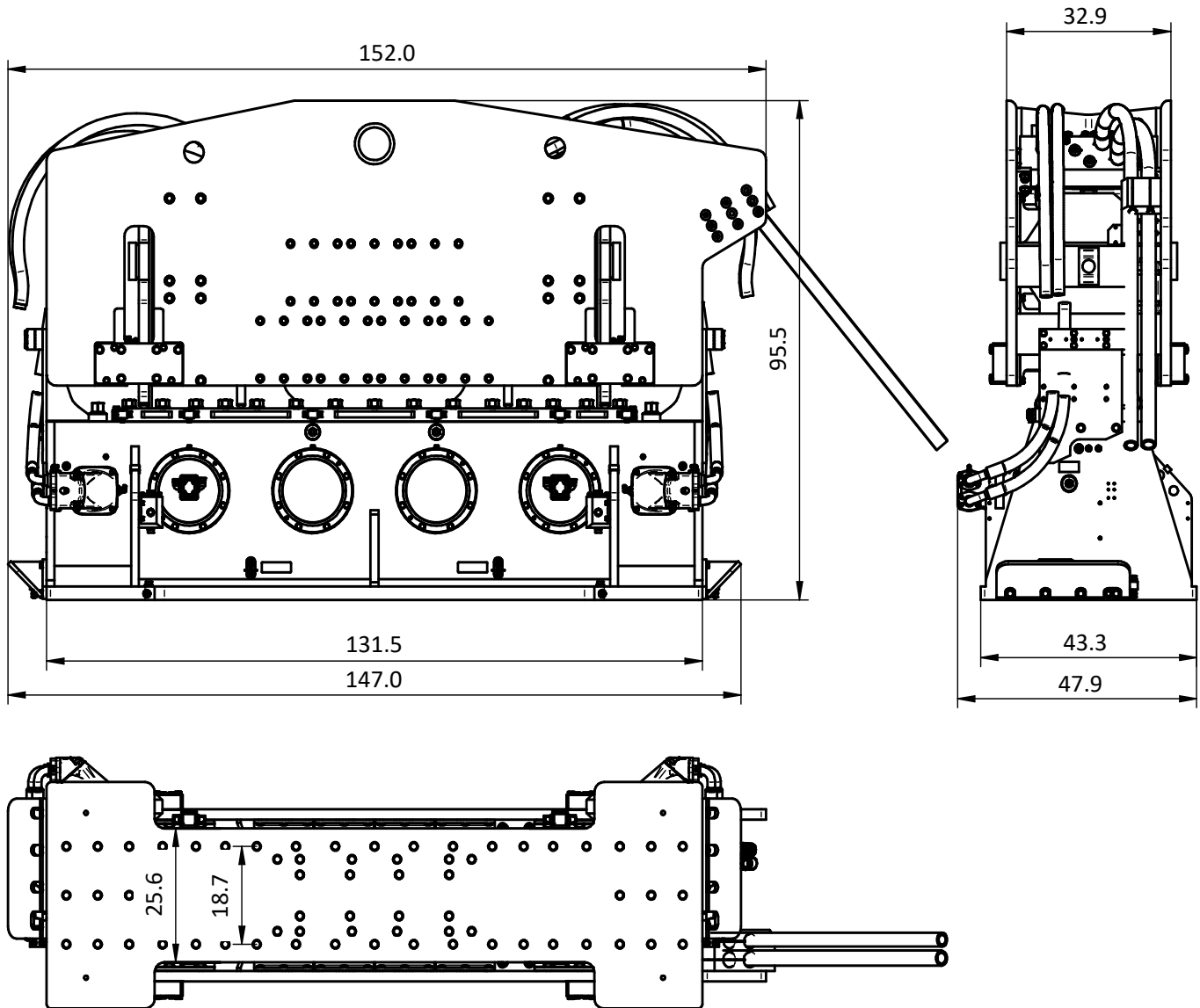

Specifications

ICE 150NF

Eccentric moment	0-13020.8 lbs in	Clamps:	
Max. centrifugal force	0-362.4 US tn	Double clamps	200TC
Max. frequency	1400 rpm	Transport weight per piece	2976 lbs
Max. amplitude excluding PPK 200TC (2x)	1.04 in		
Max. amplitude including PPK 200TC (2x)	0.84 in		
Max. static line-pull	128.5 US tn		
Max. operating pressure	5076 psi	Powerpack:	
Max. oil flow	342 gal/min	Model	1400 series
Forced lubrication	yes		
Dynamic weight excluding PPK 200TC (2x)	25133 lbs	Hose set:	
Dynamic weight including PPK 200TC (2x)	31085 lbs	Length	197 ft
Total weight excluding PPK 200TC (2x) & hoses	39198 lbs	Transport weight (±)	3616 lbs