

#### Specifications :

#### ICE 200NF

Eccentric moment	200 kgm	<b>Clamps:</b>	
Max. centrifugal force	4300 kN	Double clamps	PPK 150T (4x)
Max. frequency	1400 rpm	Transport weight per piece	1300 kg
Max. amplitude excluding PPK 150T (4x)	19 mm		
Max. amplitude including PPK 150T (4x)	15.3 mm		
Max. static line-pull	1800 kN		
Max. operating pressure	350 bar	<b>Powerpack:</b>	
Max. oil flow	1680 l/min	Model	1600 series
Forced lubrication	yes		
Dynamic weight excluding PPK 150T (4x)	21000 kg	<b>Hose set:</b>	
Dynamic weight including PPK 150T (4x)	26200 kg	Length	60 m
Total weight excluding PPK 150T (4x) & hoses	29000 kg	Transport weight (±)	3050 kg

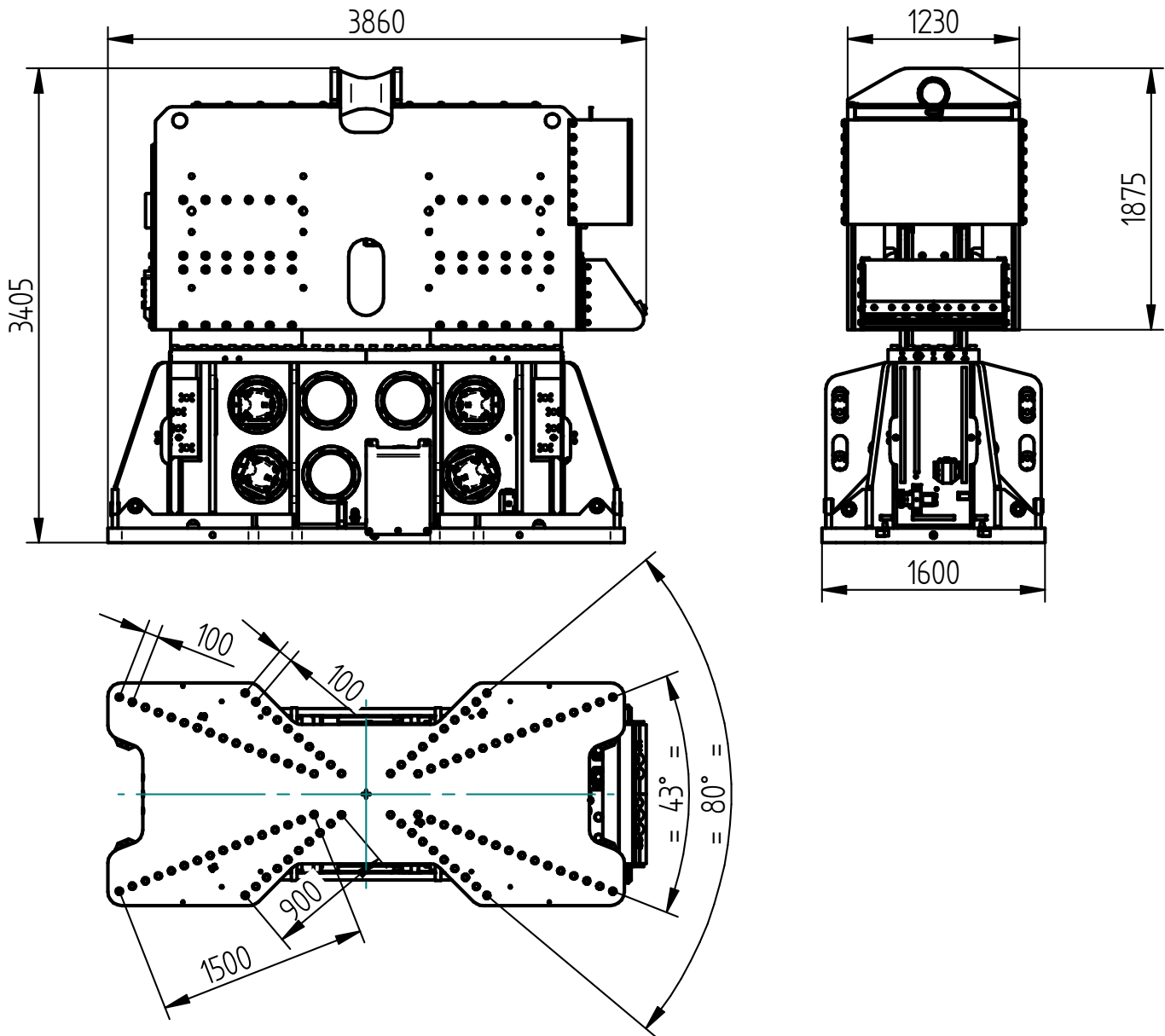

#### Technische Daten :

#### ICE 200NF

Statisches Moment	200 kgm	<b>Klemmzange:</b>	
Max. Fliehkraft	4300 kN	Rohrklemmzange	PPK 150T (4x)
Max. Drehzahl	1400 rpm	Transportgew. pro Stück	1300 kg
Max. Amplitude ohne PPK 150T (4x)	19 mm		
Max. Amplitude mit PPK 150T (4x)	15.3 mm		
Max. Statische Zugkraft	1800 kN		
Max. Betriebsdruck	350 bar	<b>Aggregat:</b>	
Max. Fördermenge	1680 l/min	Modell	1600 series
Zwangsschmierung	ja		
Dyn. Gewicht ohne PPK 150T (4x)	21000 kg	<b>Schlauchsatz:</b>	
Dyn. Gewicht mit PPK 150T (4x)	26200 kg	Länge	60 m
Gesamtgew. ohne PPK 150T (4x) & Schläuche	29000 kg	Transportgewicht (±)	3050 kg

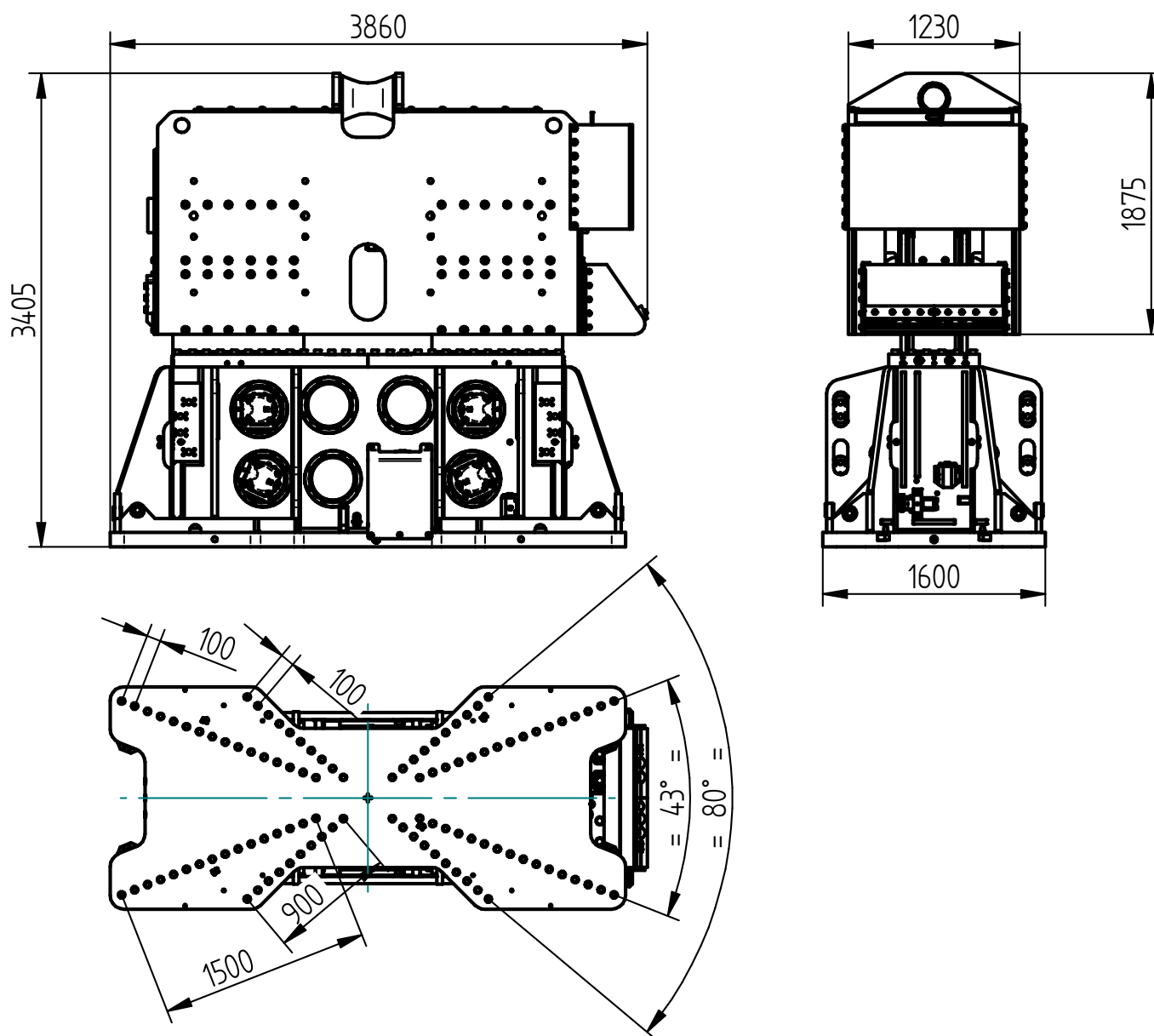

### Spécifications

### ICE 200NF

Moment excentrique	200 kgm	<b>Pinces:</b>	
Max. force centrifuge	4300 kN	Pince tube	PPK 150T (4x)
Max. fréquence	1400 rpm	Poids de transport par pièce	1300 kg
Max. amplitude sans PPK 150T (4x)	19 mm		
Max. amplitude avec PPK 150T (4x)	15.3 mm		
Force de traction statique	1800 kN		
Pression de travail max.	350 bar	<b>Groupe hydraulique:</b>	
Débit d'huile max.	1680 l/min	Modèle	1600 series
Huile lubrifiante	oui		
Poids dynamique sans PPK 150T (4x)	21000 kg	<b>Jeu de tuyau:</b>	
Poids dynamique avec PPK 150T (4x)	26200 kg	Longueur	60 m
Poids total sans PPK 150T (4x) & tuyaux	29000 kg	Poids de transport (±)	3050 kg

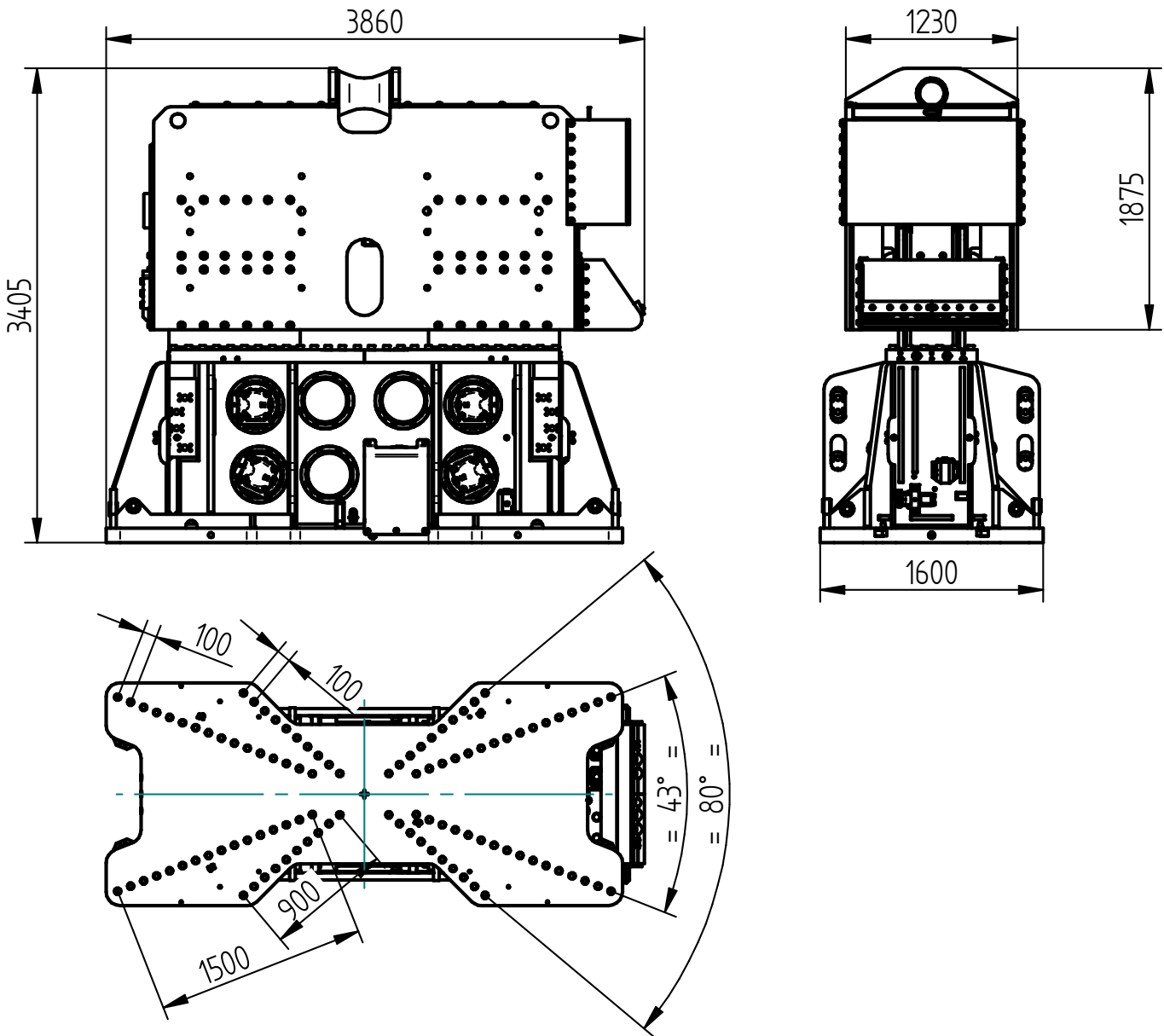

### Specificaties

### ICE 200NF

Excentrisch moment	200 kgm	<b>Klemmen:</b>	
Max. centrifugaalkracht	4300 kN	Damwandklem	PPK 150T (4x)
Max. toerental	1400 rpm	Transportgewicht per klem	1300 kg
Max. amplitude excl. PPK 150T (4x)	19 mm		
Max. amplitude incl. PPK 150T (4x)	15.3 mm		
Max. statische trekkracht	1800 kN		
Max. werkdruk	350 bar	<b>Aggregaat:</b>	
Max. oliedoorstroming	1680 l/min	Model	1600 series
Geforceerde smering	ja		
Dynamisch gewicht excl. PPK 150T (4x)	21000 kg	<b>Slangenset:</b>	
Dynamisch gewicht incl. PPK 150T (4x)	26200 kg	Lengte	60 m
Totaalgewicht excl. PPK 150T (4x) & slangen	29000 kg	Transportgewicht (±)	3050 kg

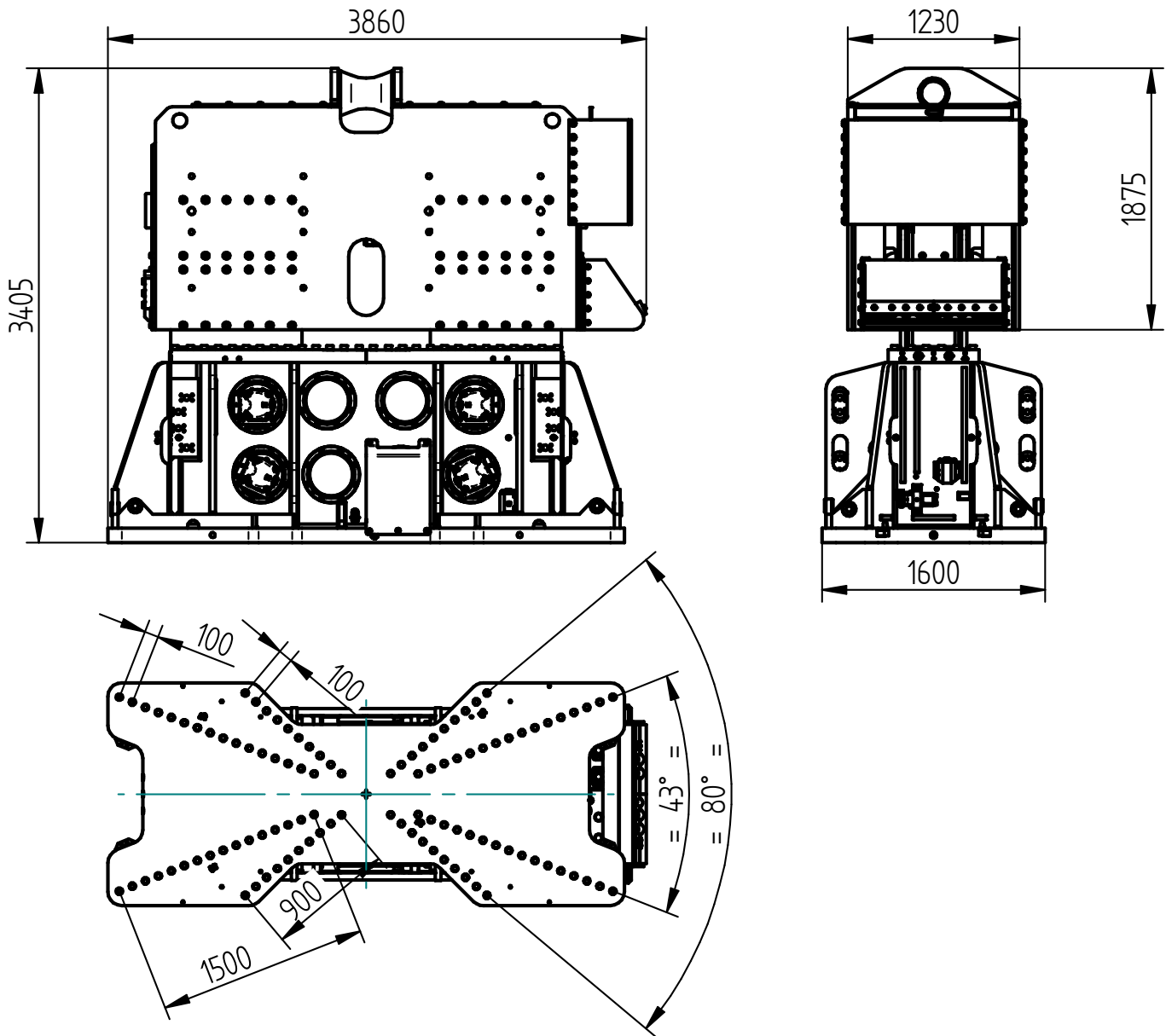

### Specificatii

### ICE 200NF

Moment excentric	200 kgm	<b>Menghina:</b>	
Forta centrifuga maxima	4300 kN	Menghina pentru palplanse	PPK 150T (4x)
Frecventa maxima	1400 rpm	Greutatea transportului pe buc.	1300 kg
Amplitudinea maxima excluzand PPK 150T (4x)	19 mm		
Amplitudinea maxima inclusiv PPK 150T (4x)	15.3 mm		
Tractiune statica maxima	1800 kN		
Presiunea maxima de lucru	350 bar	<b>Unitate de putere:</b>	
Debit maxim de ulei	1680 l/min	Model	1600 series
Ungere fortata	da		
Greutate dinamica excluzand PPK 150T (4x)	21000 kg	<b>Set furtun:</b>	
Greutate dinamica inclusiv PPK 150T (4x)	26200 kg	Lungime	60 m
Greutate totala excl. PPK 150T (4x) & furtunuri	29000 kg	Greutatea transportului (±)	3050 kg

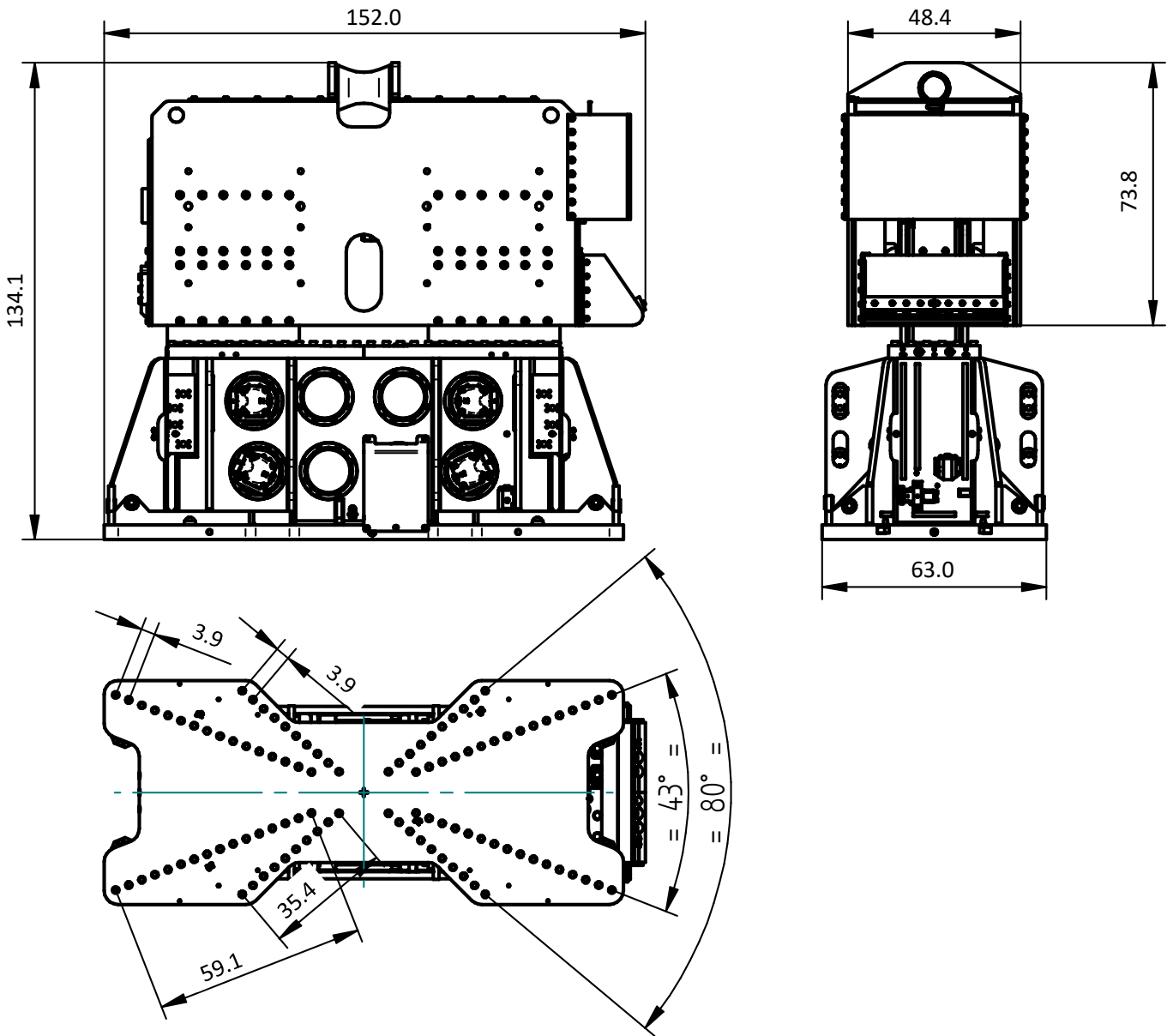

Specifications		ICE 200NF	
Eccentric moment	0-17361.1 lbs in	<b>Clamps:</b>	
Max. centrifugal force	0-483.4 US tn	Sheet pile clamp	PPK 150T (4x)
Max. frequency	1400 rpm	Transport weight per piece	2866 lbs
Max. amplitude excluding PPK 150T (4x)	0.75 in		
Max. amplitude including PPK 150T (4x)	0.60 in		
Max. static line-pull	183.6 US tn		
Max. operating pressure	5076 psi	<b>Powerpack:</b>	
Max. oil flow	444 gal/min	Model	1600 series
Forced lubrication	yes		
Dynamic weight excluding PPK 150T (4x)	46297 lbs	<b>Hose set:</b>	
Dynamic weight including PPK 150T (4x)	57761 lbs	Length	197 ft
Total weight excluding PPK 150T (4x) & hoses	63934 lbs	Transport weight (±)	6724 lbs