

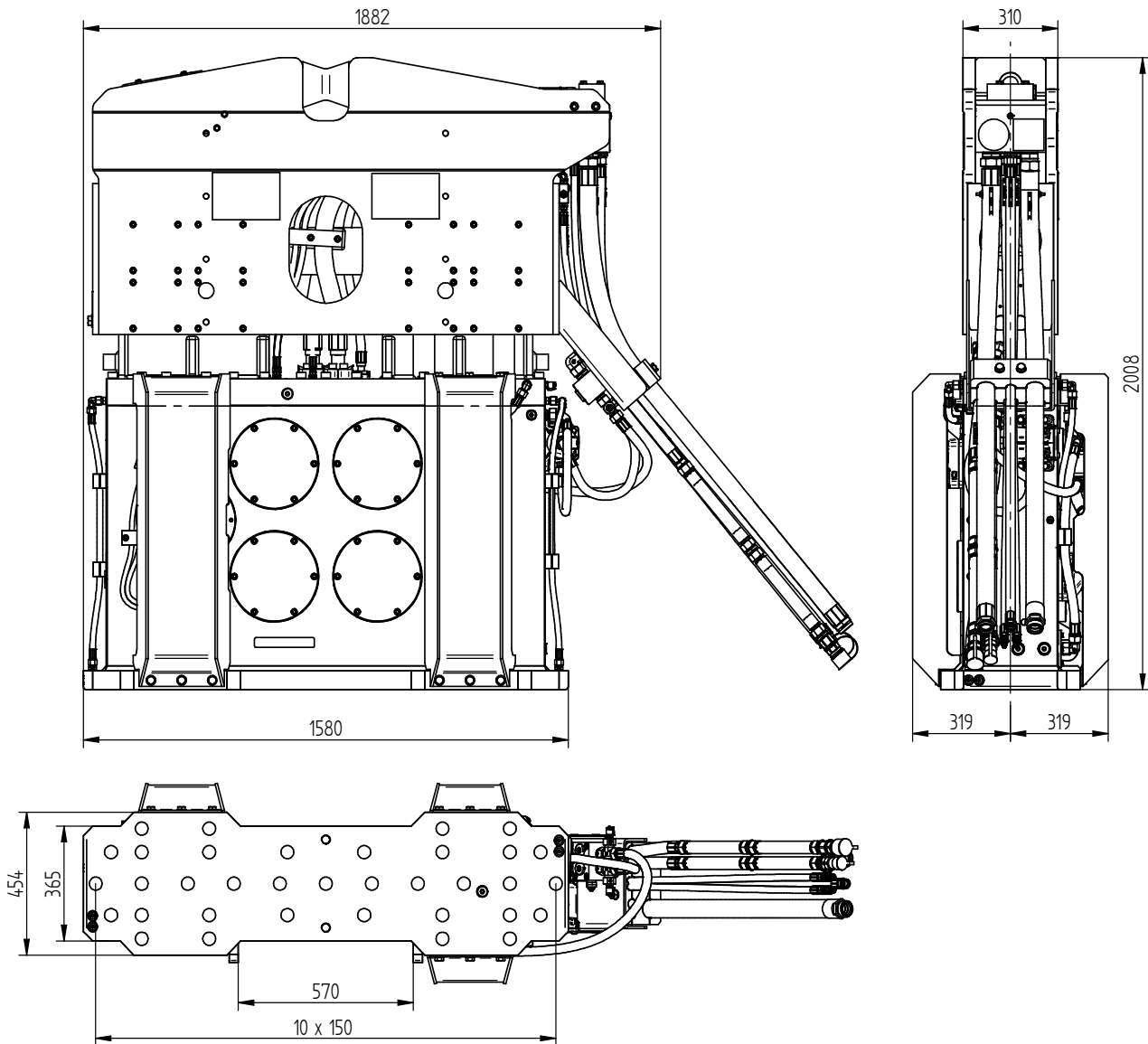

Specification sheet

PVE 20VM

Vibro Hammer



Specifications :

PVE 20VM

Eccentric moment	19 kgm	Clamps:	
Max. centrifugal force	1100 kN	Sheet pile clamp	DWK 150T-L
Max. frequency	2300 rpm	Transport weight per piece	1100 kg
Max. amplitude excl. DWK 150T(-L)	15 mm	Double clamps	PPK 80T
Max. amplitude incl. DWK 150T(-L)	10.4 mm	Transport weight per piece	500 kg
Max. static line-pull	240 kN		
Max. operating pressure	350 bar	Powerpack:	
Max. oil flow	498 l/min	Model	500 series
Forced lubrication	yes		
Dynamic weight excl. DWK 150T(-L)	2550 kg	Hose set:	
Dynamic weight incl. DWK 150T(-L)	3650 kg	Length	30 m
Total weight excl. DWK 150T(-L) & hoses	3650 kg	Transport weight (±)	615 kg

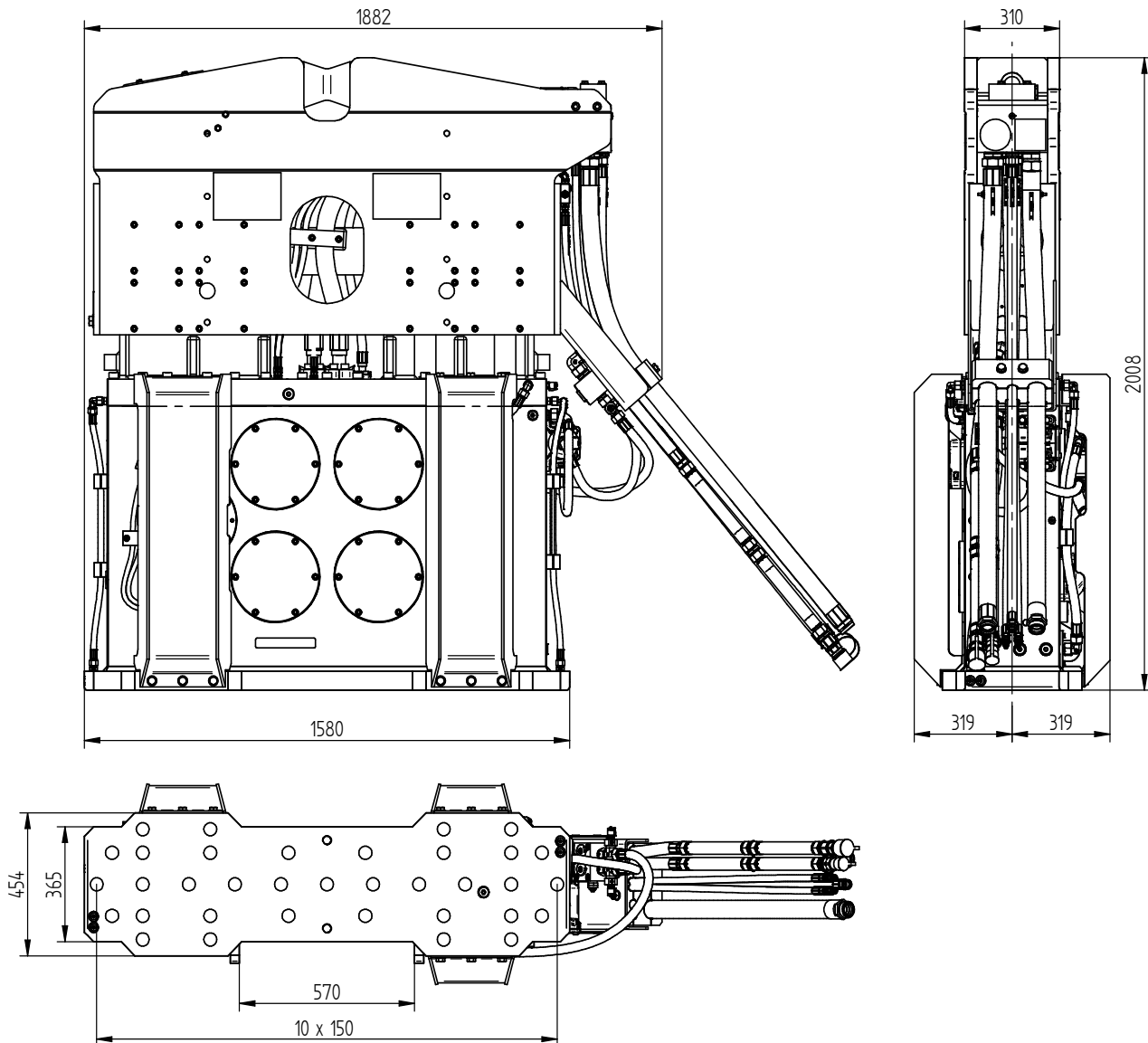
Technische Daten :
PVE 20VM

Statisches Moment	19 kgm	Klemmzange:	
Max. Fliehkraft	1100 kN	Universalzange	DWK 150T-L
Max. Drehzahl	2300 rpm	Transportgew. pro Stück	1100 kg
Max. Amplitude ohne DWK 150T(-L)	15 mm	Rohrklemmzange	PPK 80T
Max. Amplitude mit DWK 150T(-L)	10.4 mm	Transportgew. pro Stück	500 kg
Max. Statische Zugkraft	240 kN		
Max. Betriebsdruck	350 bar	Aggregat:	
Max. Fördermenge	498 l/min	Modell	500 series
Zwangsschmierung	ja		
Dyn. Gewicht ohne DWK 150T(-L)	2550 kg	Schlauchsatz:	
Dyn. Gewicht mit DWK 150T(-L)	3650 kg	Länge	30 m
Gesamtgew. Ohne DWK 150T(-L) & Schläuche	3650 kg	Transportgewicht (±)	615 kg

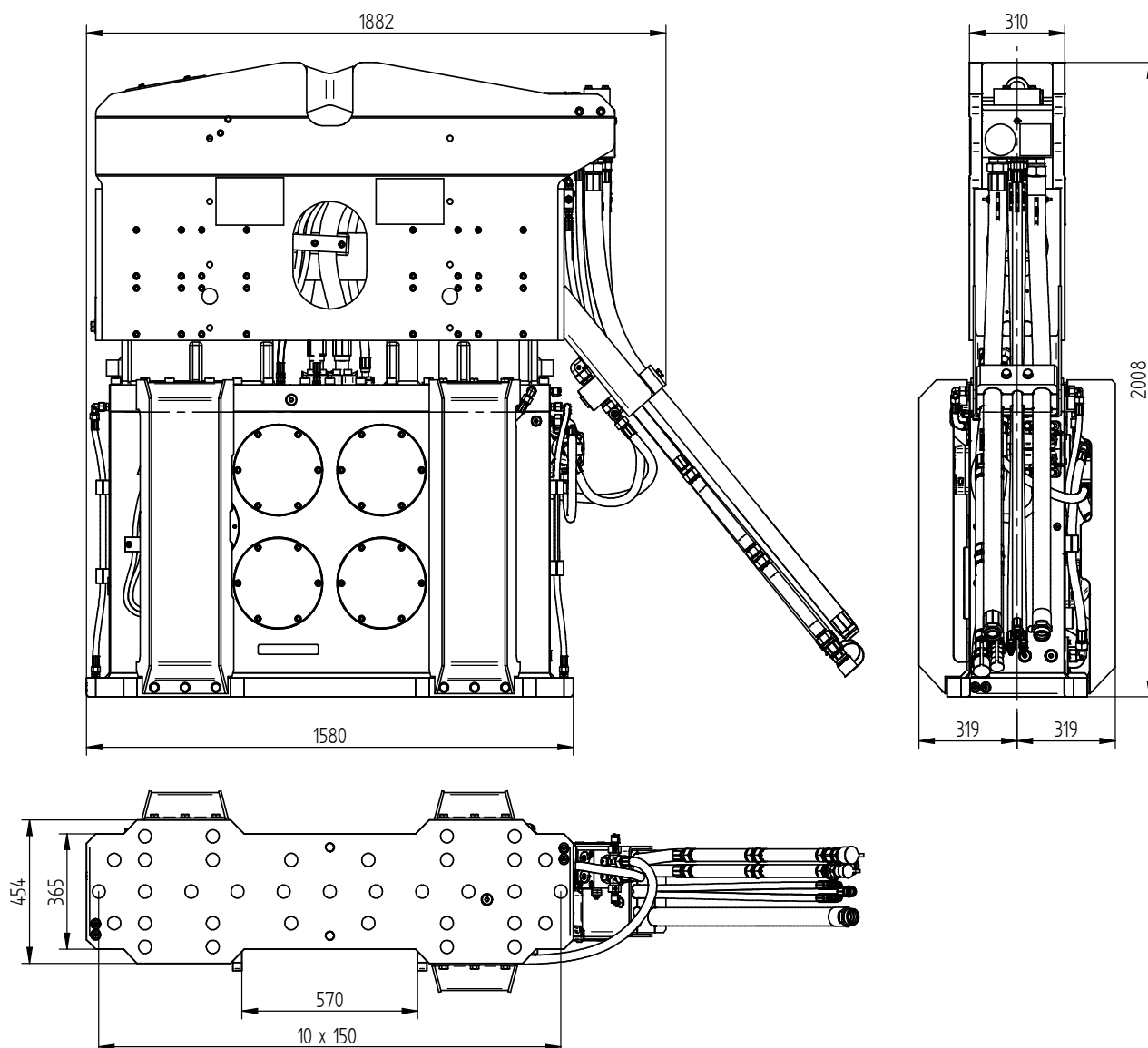

Spécifications

PVE 20VM

Moment excentrique	19 kgm	Pinces:	
Max. force centrifuge	1100 kN	Pince palplanche	DWK 150T-L
Max. fréquence	2300 rpm	Poids de transport par pièce	1100 kg
Max. amplitude sans DWK 150T(-L)	15 mm	Pince tube	PPK 80T
Max. amplitude avec DWK 150T(-L)	10.4 mm	Poids de transport par pièce	500 kg
Force de traction statique	240 kN		
Pression de travail max.	350 bar	Groupe hydraulique:	
Débit d'huile max.	498 l/min	Modèle	500 series
Huile lubrifiante	oui		
Poids dynamique sans DWK 150T(-L)	2550 kg	Jeu de tuyau:	
Poids dynamique avec DWK 150T(-L)	3650 kg	Longueur	30 m
Poids total sans DWK 150T(-L) & tuyaux	3650 kg	Poids de transport (±)	615 kg

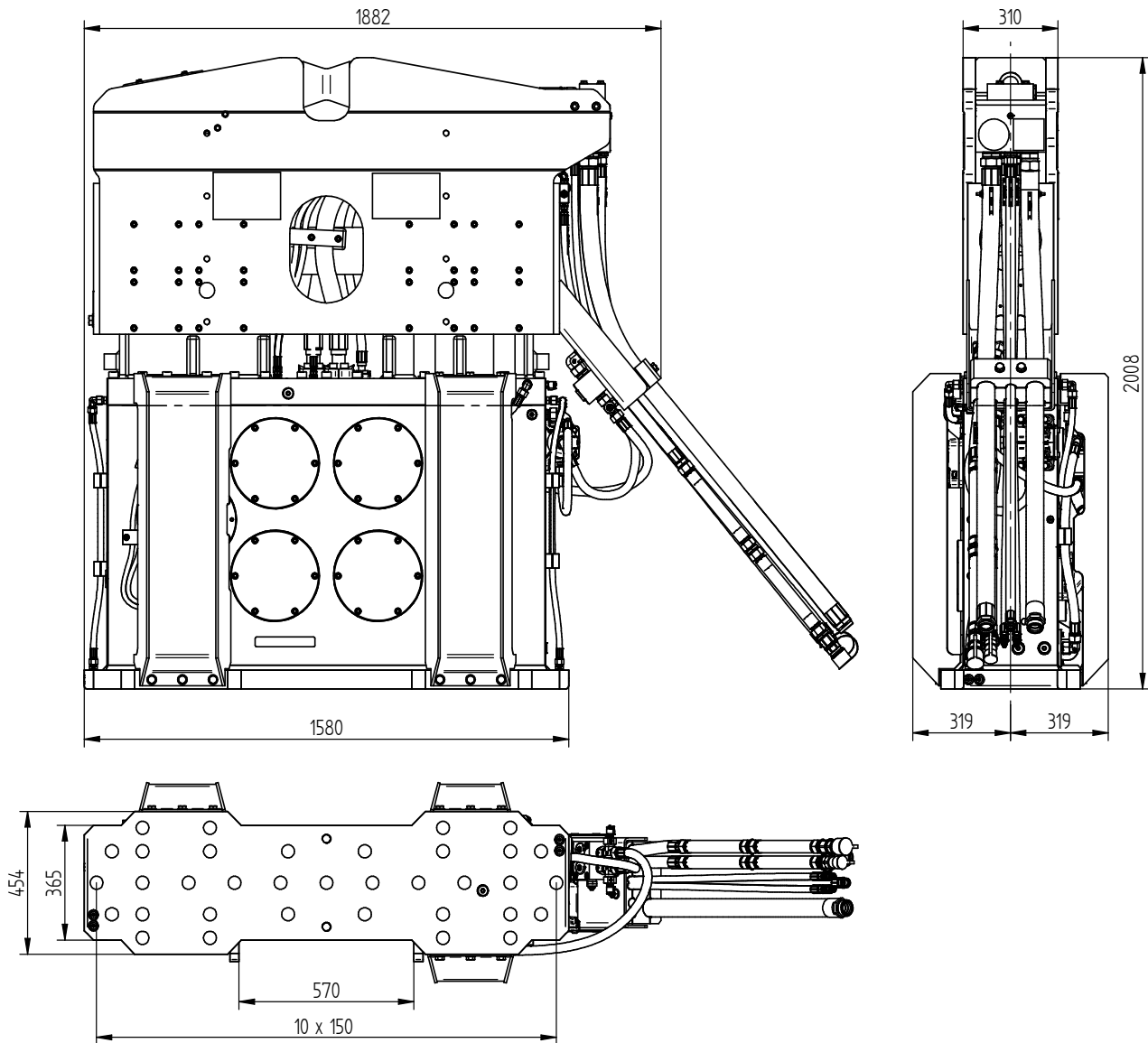

Specificaties

PVE 20VM

Excentrisch moment	19 kgm	Klemmen:	
Max. centrifugaalkracht	1100 kN	Damwandklem	DWK 150T-L
Max. toerental	2300 rpm	Transportgewicht per klem	1100 kg
Max. amplitude excl. DWK 150T(-L)	15 mm	Pijpenklem	PPK 80T
Max. amplitude incl. DWK 150T(-L)	10.4 mm	Transportgewicht per klem	500 kg
Max. statische trekkracht	240 kN		
Max. werkdruk	350 bar	Aggregaat:	
Max. oliedoorstroming	498 l/min	Model	500 series
Geforceerde smering	ja		
Dynamisch gewicht excl. DWK 150T(-L)	2550 kg	Slangenset:	
Dynamisch gewicht incl. DWK 150T(-L)	3650 kg	Lengte	30 m
Totaalgewicht excl. DWK 150T(-L) & slangen	3650 kg	Transportgewicht (±)	615 kg

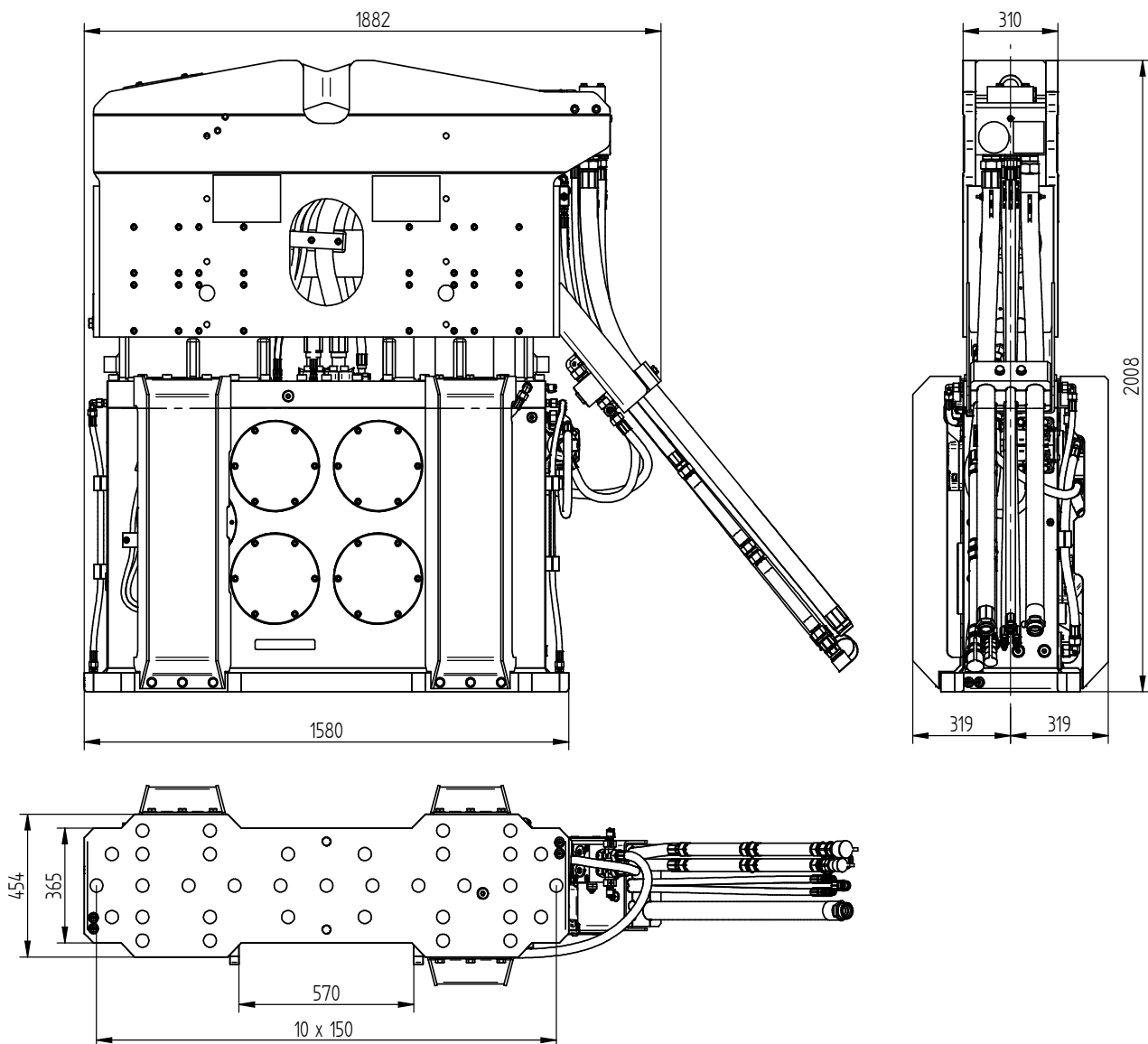
**Specificatii****PVE 20VM**

Moment excentric	19 kgm	Menghina:	
Forta centrifuga maxima	1100 kN	Menghina pentru palplanse	DWK 150T-L
Frecventa maxima	2300 rpm	Greutatea transportului pe buc.	1100 kg
Amplitudinea maxima exclusiv DWK 150T(-L)	15 mm	Menghina dubla	PPK 80T
Amplitudinea maxima inclusiv DWK 150T(-L)	10.4 mm	Greutatea transportului pe buc.	500 kg
Tractiune statica maxima	240 kN	Unitate de putere:	
Presiunea maxima de lucru	350 bar	Model	500 series
Debit maxim de ulei	498 l/min		
Ungere fortata	da	Set furtun:	
Greutate dinamica exclusiv DWK 150T(-L)	2550 kg	Lungime	30 m
Greutate dinamica inclusiv DWK 150T(-L)	3650 kg	Greutatea transportului	615 kg
Greutate totala cu furtun atasat DWK 150T(-L)	3650 kg		



Specifications

PVE 20VM

Vibro Hammer

USA

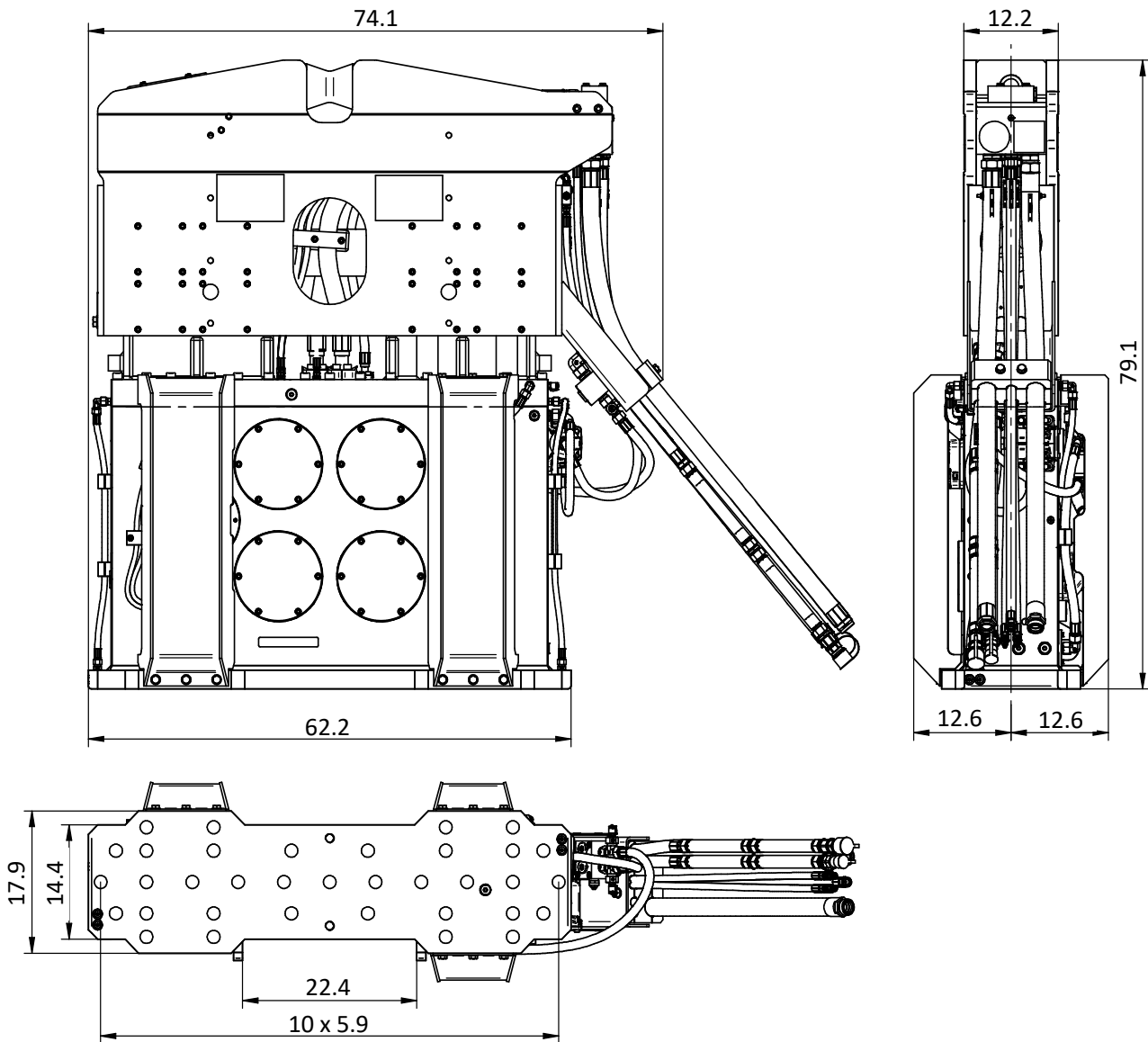

Specifications

PVE 20VM

Eccentric moment	0-1649.3 lbs in	Clamps:	
Max. centrifugal force	0-123.7 US tn	Sheet pile clamp	DWK 150T-L
Max. frequency	2300 rpm	Transport weight per piece	2425 lbs
Max. amplitude excluding DWK 150T(-L)	0.59 in	Double clamps	PPK 80T
Max. amplitude including DWK 150T(-L)	0.41 in	Transport weight per piece	1102 lbs
Max. static line-pull	24.5 US tn		
Max. operating pressure	5076 psi	Powerpack:	
Max. oil flow	132 gal/min	Model	500 series
Forced lubrication	yes		
Dynamic weight excluding DWK 150T(-L)	5622 lbs	Hose set:	
Dynamic weight including DWK 150T(-L)	8047 lbs	Length	98 ft
Total weight excluding DWK 150T(-L) & hoses	8047 lbs	Transport weight (±)	1356 lbs