

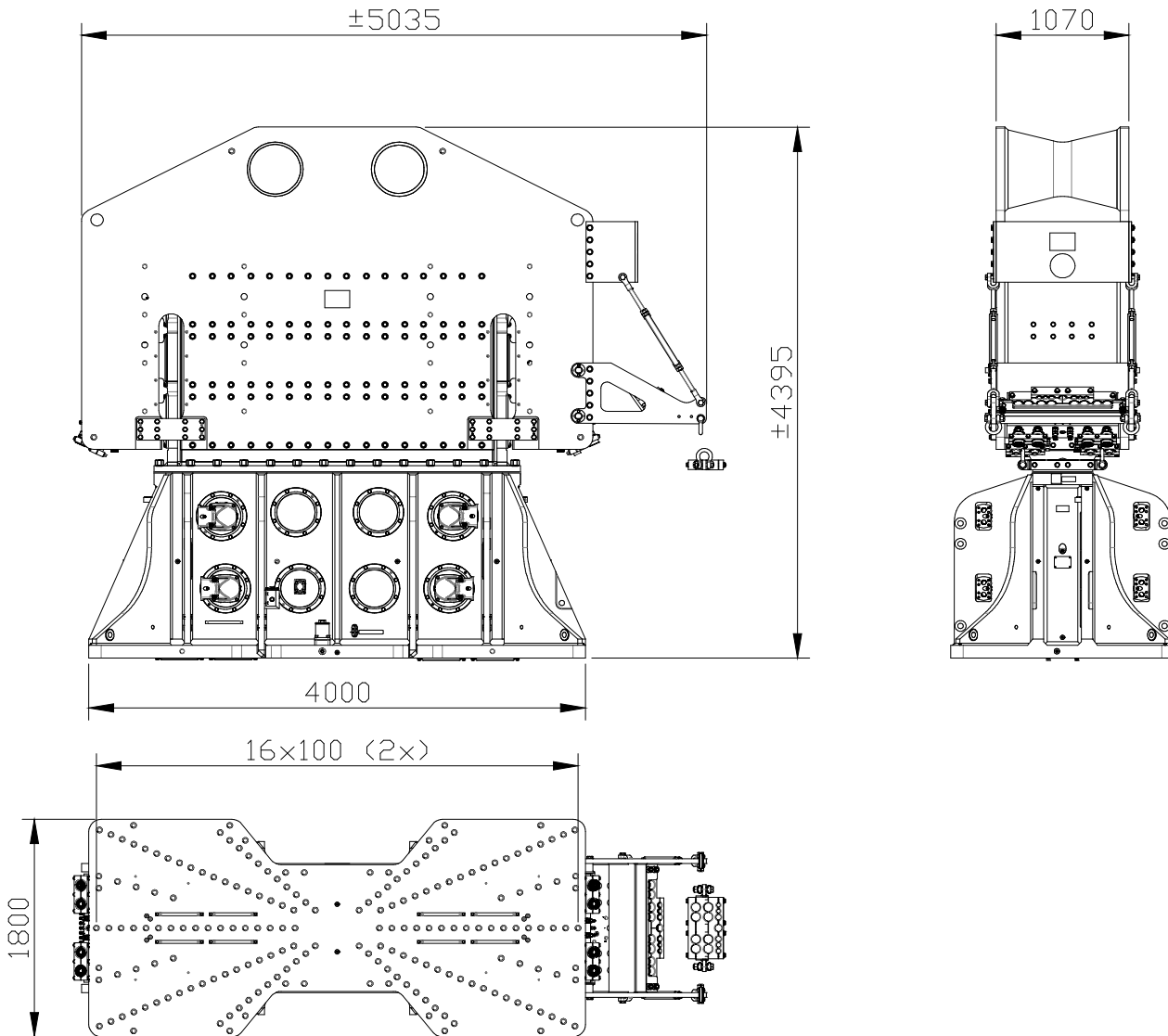

# Specification sheet

## PVE 300M

### Vibro Hammer



#### Specifications :

#### PVE 300M

Eccentric moment	300 kgm	<b>Clamps:</b>	
Max. centrifugal force	6150 kN	Double clamps	210TC (4x)
Max. frequency	1400 rpm	Transport weight per piece	1600 kg
Max. amplitude excl. 210TC (4x)	21 mm		
Max. amplitude incl. 210TC (4x)	17 mm		
Max. static line-pull	4000 kN		
Max. operating pressure	350 bar	<b>Powerpack:</b>	
Max. oil flow	2800 l/min	Model	3200 series
Forced lubrication	yes		
Dynamic weight excl. 210TC (4x)	27250 kg	<b>Hose set:</b>	
Dynamic weight incl. 210TC (4x)	33650 kg	Length	60 m
Total weight excl. 210TC (4x) & hoses	47000 kg	Transport weight (±)	5200 kg

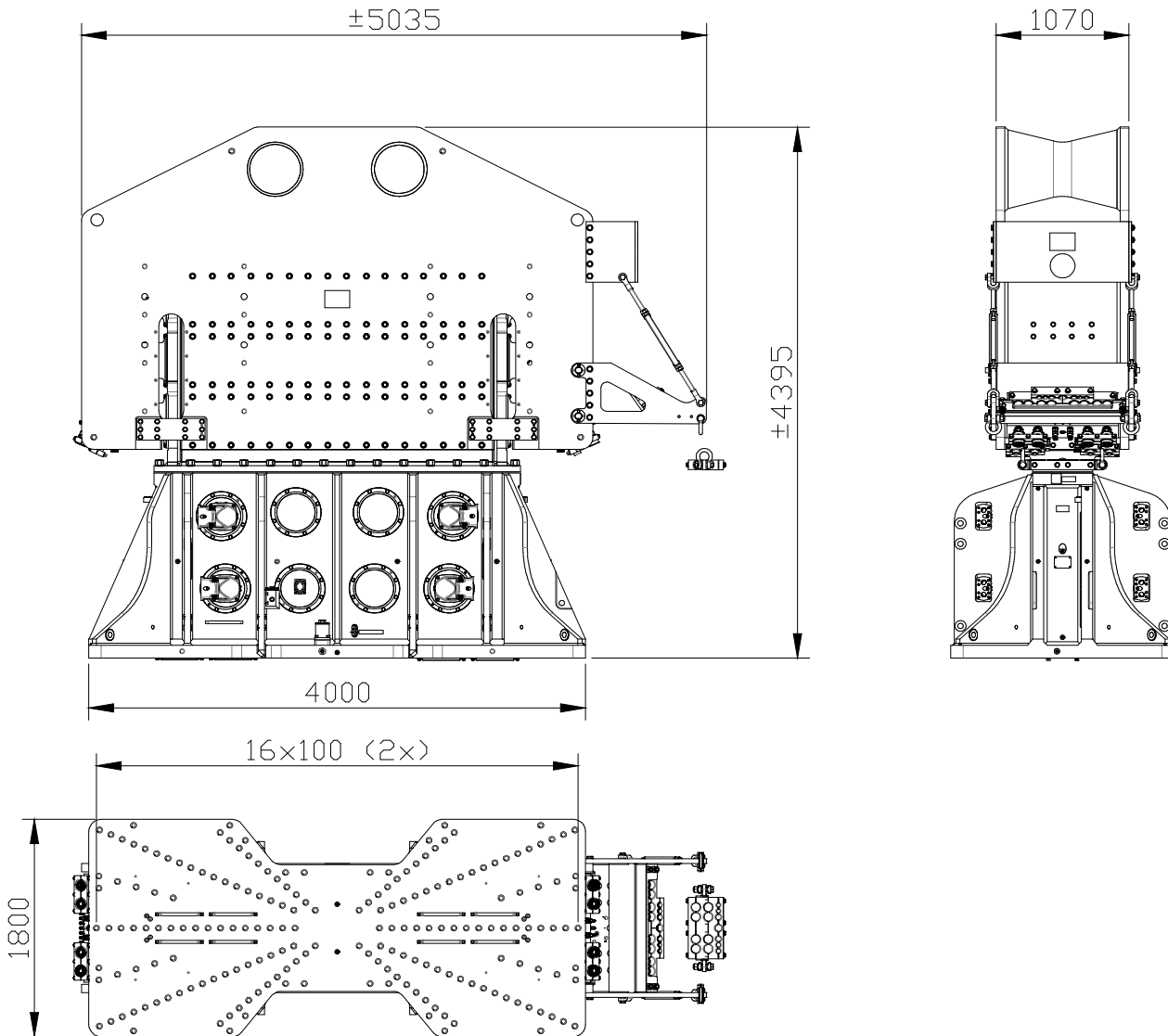

#### Technische Daten :

#### PVE 300M

Statisches Moment	300 kgm	<b>Klemmzange:</b>	
Max. Fliehkraft	6150 kN	Rohrklemmzange	210TC (4x)
Max. Drehzahl	1400 rpm	Transportgew. pro Stück	1600 kg
Max. Amplitude ohne 210TC (4x)	21 mm		
Max. Amplitude mit 210TC (4x)	17 mm		
Max. Statische Zugkraft	4000 kN		
Max. Betriebsdruck	350 bar	<b>Aggregat:</b>	
Max. Fördermenge	2800 l/min	Modell	3200 series
Zwangsschmierung	ja		
Dyn. Gewicht ohne 210TC (4x)	27250 kg	<b>Schlauchsatz:</b>	
Dyn. Gewicht mit 210TC (4x)	33650 kg	Länge	60 m
Gesamtgew. ohne 210TC (4x) & Schläuche	47000 kg	Transportgewicht (±)	5200 kg

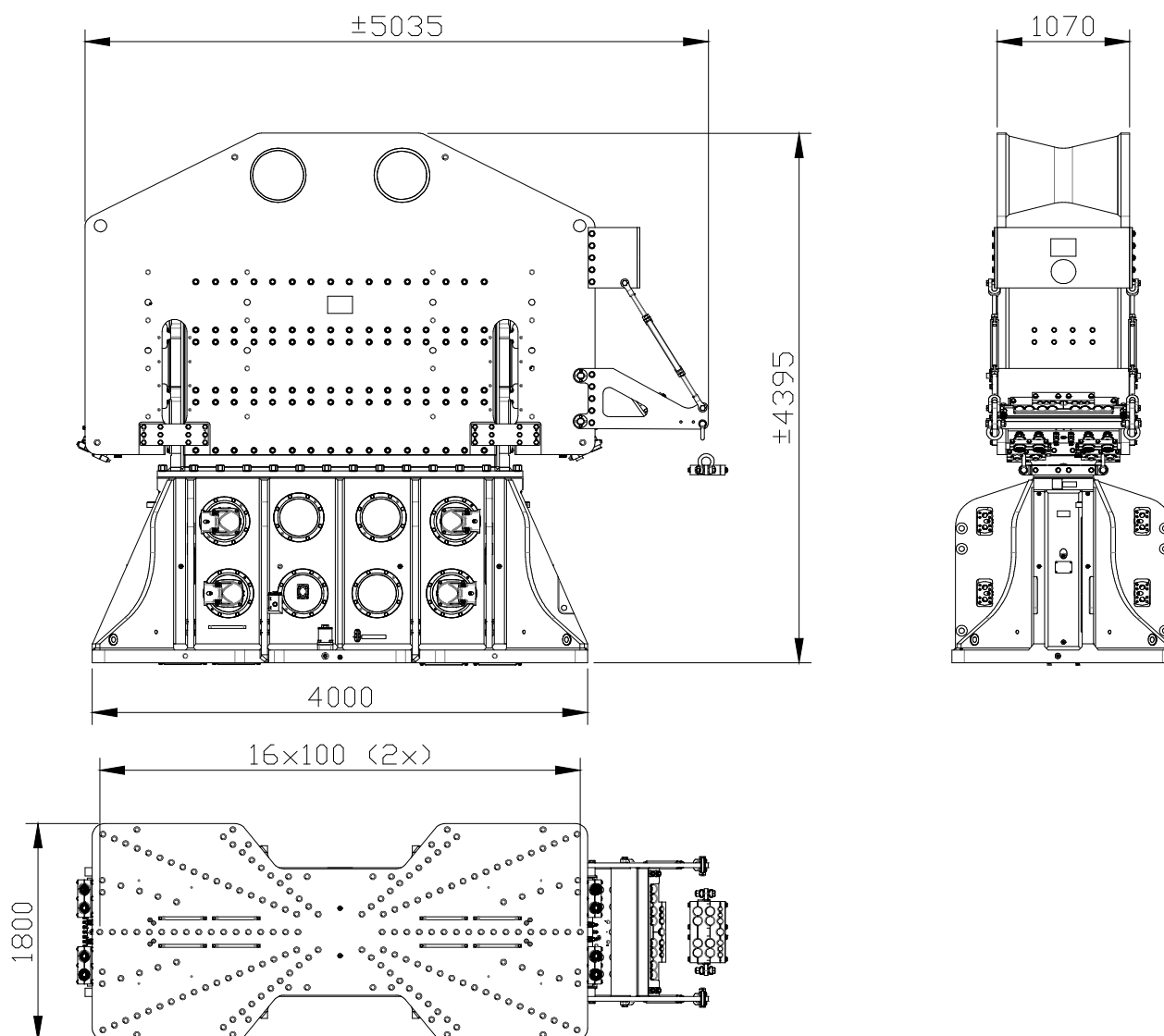

### Spécifications

### PVE 300M

Moment excentrique	300 kgm	<b>Pinces:</b>	
Max. force centrifuge	6150 kN	Pince tube	210TC (4x)
Max. fréquence	1400 rpm	Poids de transport par pièce	1600 kg
Max. amplitude sans 210TC (4x)	21 mm		
Max. amplitude avec 210TC (4x)	17 mm		
Force de traction statique	4000 kN		
Pression de travail max.	350 bar	<b>Groupe hydraulique:</b>	
Débit d'huile max.	2800 l/min	Modèle	3200 series
Huile lubrifiante	oui		
Poids dynamique sans 210TC (4x)	27250 kg	<b>Jeu de tuyau:</b>	
Poids dynamique avec 210TC (4x)	33650 kg	Longueur	60 m
Poids total sans 210TC (4x) & tuyaux	47000 kg	Poids de transport (±)	5200 kg

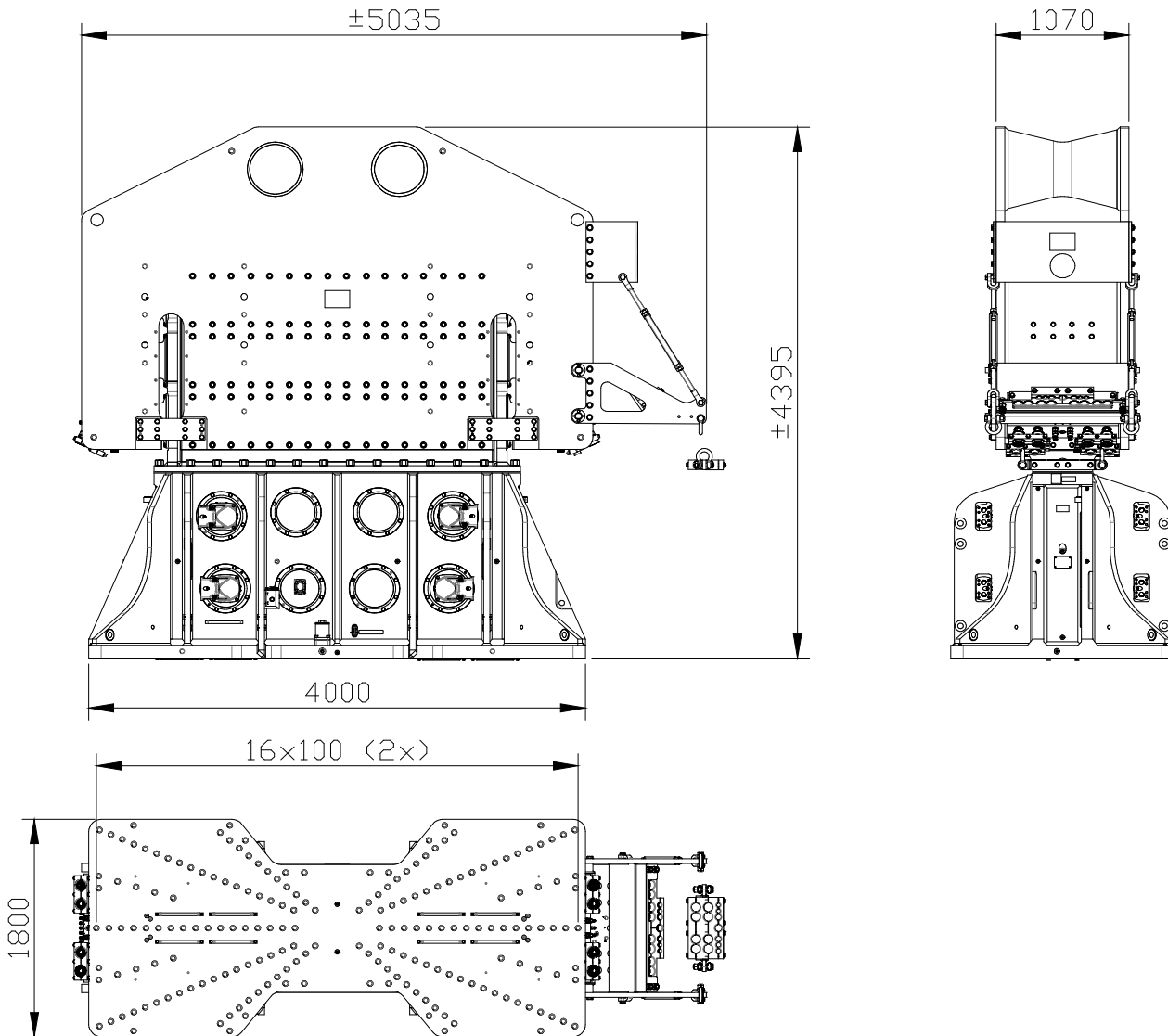

### Specificaties

### PVE 300M

Excentrisch moment	300 kgm	<b>Klemmen:</b>	
Max. centrifugaalkracht	6150 kN	Pijpenklem	210TC (4x)
Max. toerental	1400 rpm	Transportgewicht per klem	1600 kg
Max. amplitude excl. 210TC (4x)	21 mm		
Max. amplitude incl. 210TC (4x)	17 mm		
Max. statische trekkracht	4000 kN		
Max. werkdruk	350 bar	<b>Aggregaat:</b>	
Max. oliedoorstroming	2800 l/min	Model	3200 series
Geforceerde smering	ja		
Dynamisch gewicht excl. 210TC (4x)	27250 kg	<b>Slangenset:</b>	
Dynamisch gewicht incl. 210TC (4x)	33650 kg	Lengte	60 m
Totaalgewicht excl. 210TC (4x) & slangen	47000 kg	Transportgewicht (±)	5200 kg

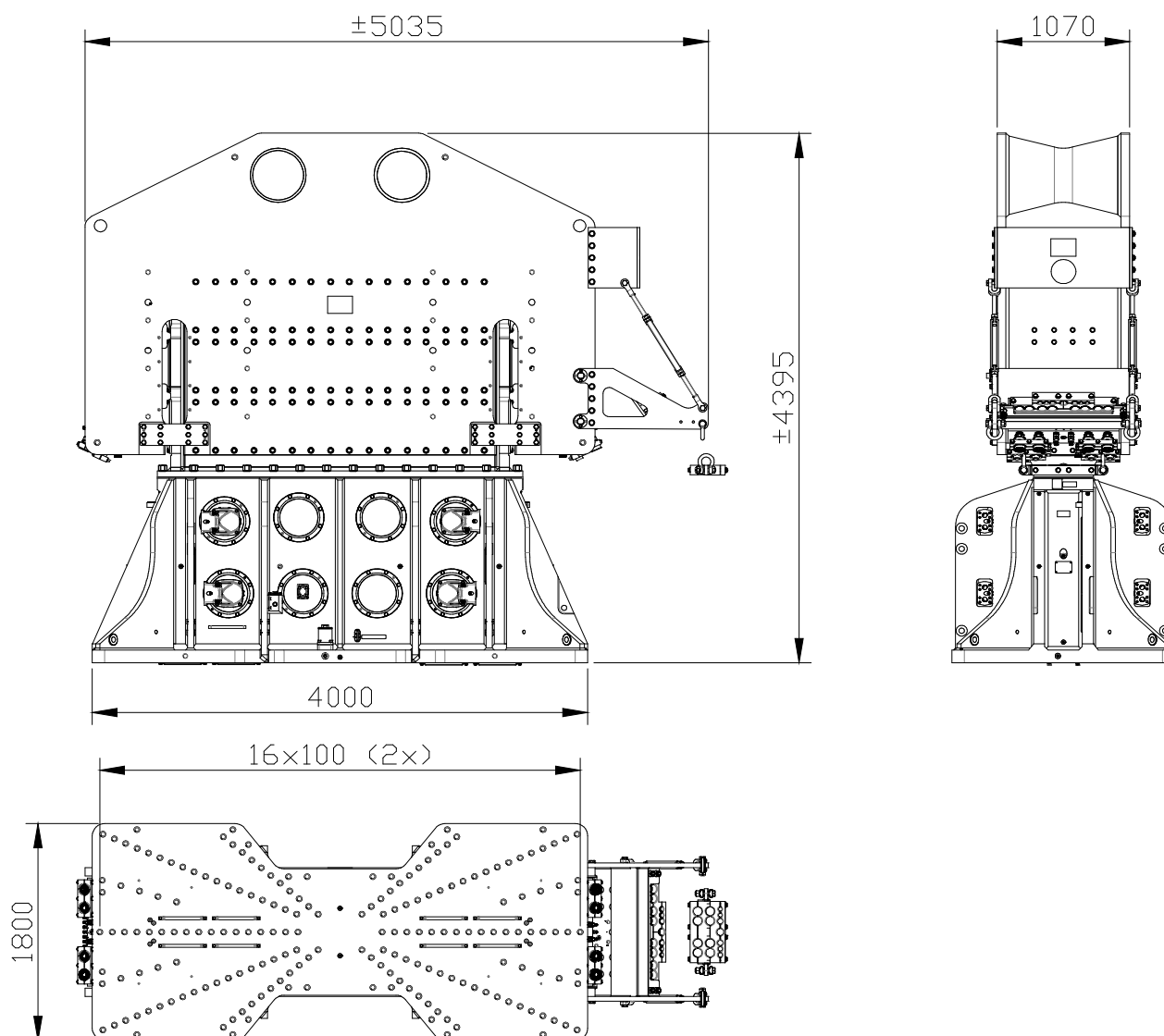

### Specificatii

### PVE 300M

Moment excentric	300 kgm	<b>Menghina:</b>	
Forta centrifuga maxima	6150 kN	Menghina dubla	210TC (4x)
Frecventa maxima	1400 rpm	Greutatea transportului pe buc.	1600 kg
Amplitudinea maxima exclusiv 210TC (4x)	21 mm		
Amplitudinea maxima inclusiv 210TC (4x)	17 mm		
Tractiune statica maxima	4000 kN		
Presiunea maxima de lucru	350 bar	<b>Unitate de putere:</b>	
Debit maxim de ulei	2800 l/min	Model	3200 series
Ungere fortata	da		
Greutate dinamica exclusiv 210TC (4x)	27250 kg	<b>Set furtun:</b>	
Greutate dinamica inclusiv 210TC (4x)	33650 kg	Lungime	60 m
Greutate totala cu furtun atasat 210TC (4x)	47000 kg	Greutatea transportului	5200 kg



# Specifications

## PVE 300M

### Vibro Hammer

USA

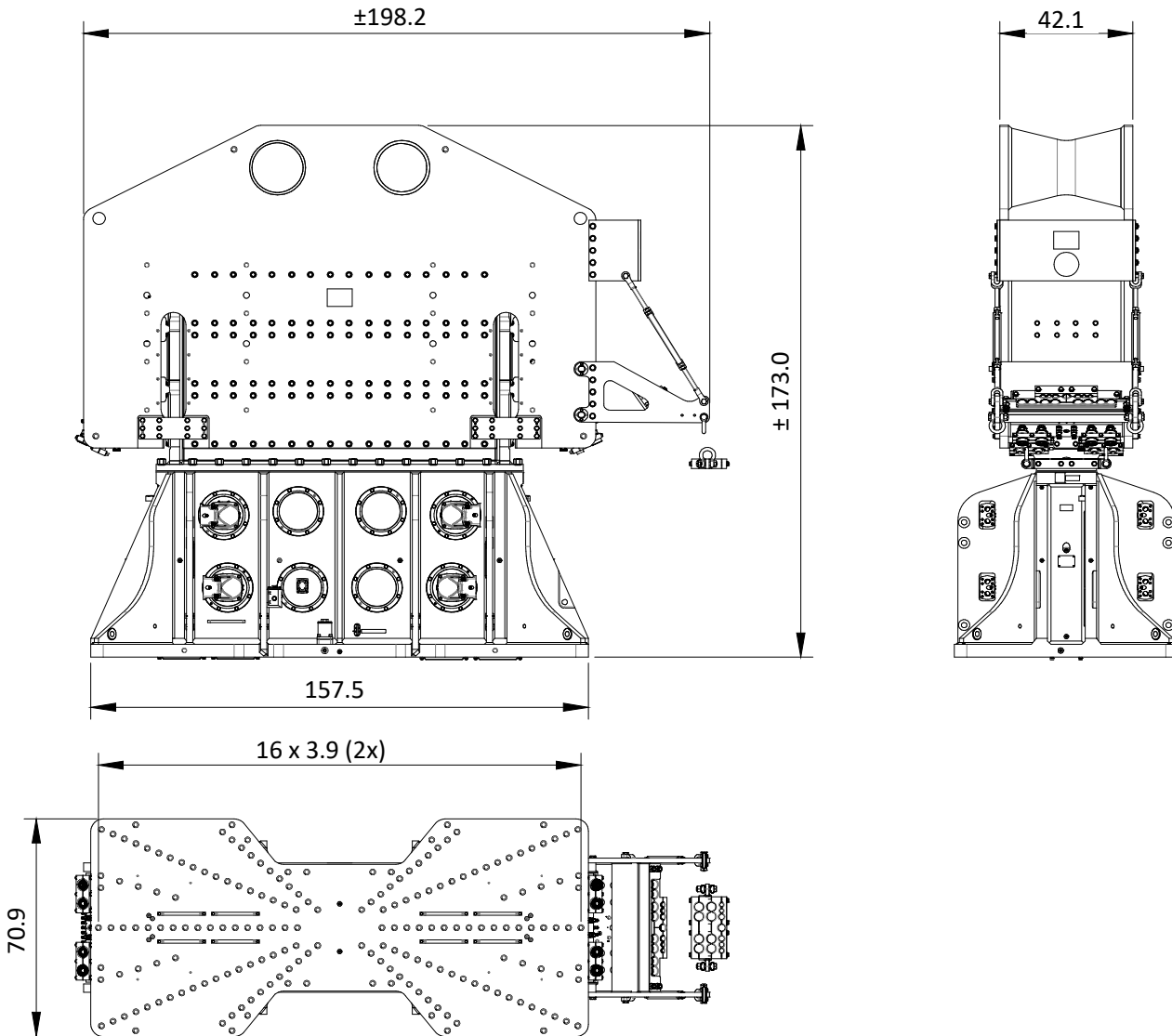

### Specifications

### PVE 300M

Eccentric moment	0-26041.7 lbs in	<b>Clamps:</b>	
Max. centrifugal force	0-691.3 US tn	Double clamps	210TC (4x)
Max. frequency	1400 rpm	Transport weight per piece	3527 lbs
Max. amplitude excluding 210TC (4x)	0.83 in		
Max. amplitude including 210TC (4x)	N/A in		
Max. static line-pull	407.9 US tn		
Max. operating pressure	5076 psi	<b>Powerpack:</b>	
Max. oil flow	740 gal/min	Model	3200 series
Forced lubrication	yes		
Dynamic weight excluding 210TC (4x)	60076 lbs	<b>Hose set:</b>	
Dynamic weight including 210TC (4x)	74186 lbs	Length	197 ft
Total weight excluding 210TC (4x) & hoses	1E+05 lbs	Transport weight (±)	11464 lbs