



Specification sheet

PVE 32VMR

Vibro Hammer

English

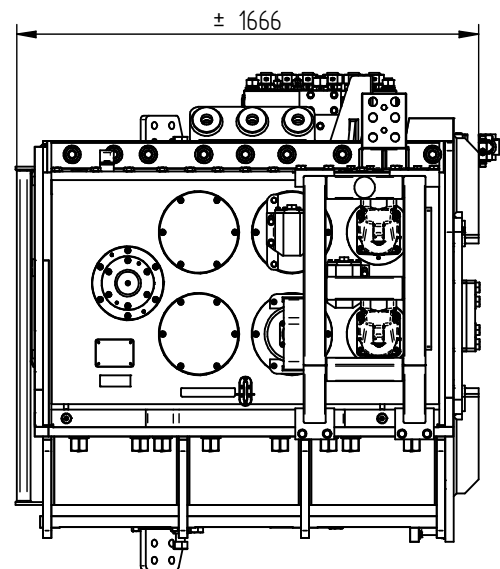
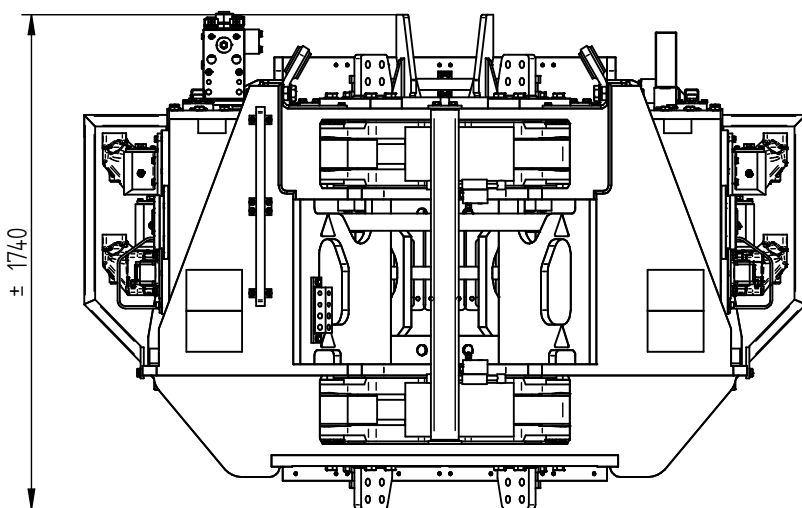
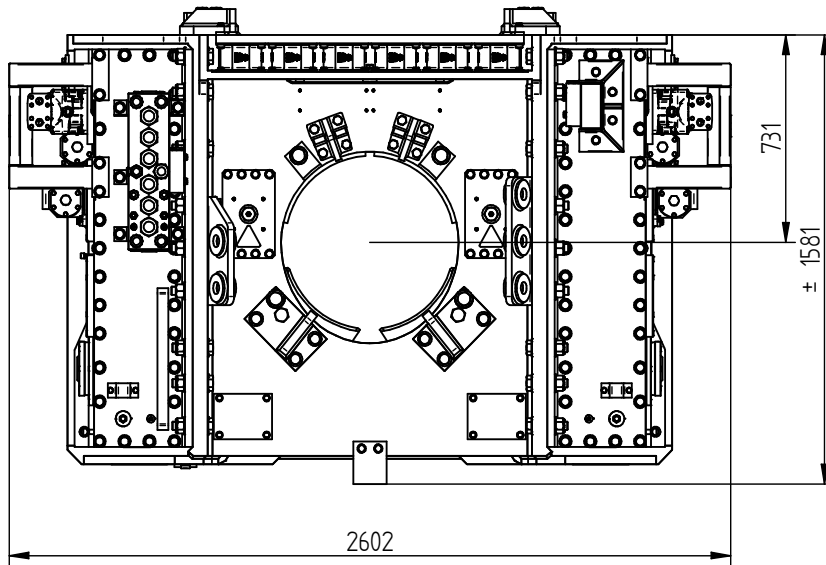

Specifications :

PVE 32VMR

Eccentric moment	32 kgm	Clamps:	
Max. centrifugal force	1800 kN	Sheet pile clamp	N/A
Max. frequency	2300 rpm	Transport weight per piece	N/A kg
Max. amplitude	5 mm	Double clamps	N/A
Max. amplitude incl. clamp	N/A mm	Transport weight per piece	N/A kg
Max. static line-pull	400 kN		
Max. operating pressure	350 bar	Powerpack:	
Max. oil flow	860 l/min	Model	900 series
Forced lubrication	yes		
Dynamic weight	12000 kg	Hose set:	
Dynamic weight incl. clamp	N/A kg	Length	N/A m
Total weight excl. hoses	12500 kg	Transport weight (±)	N/A kg

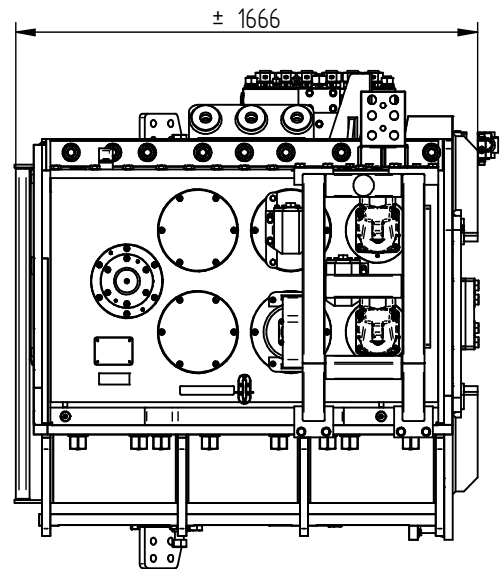
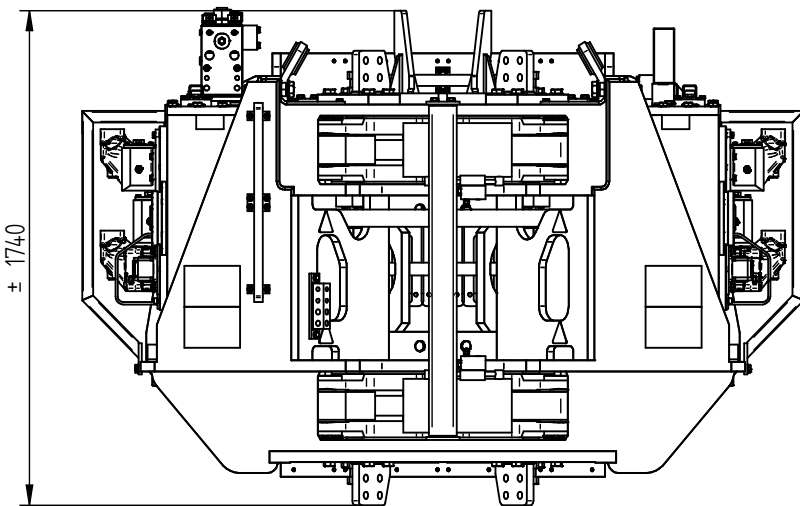
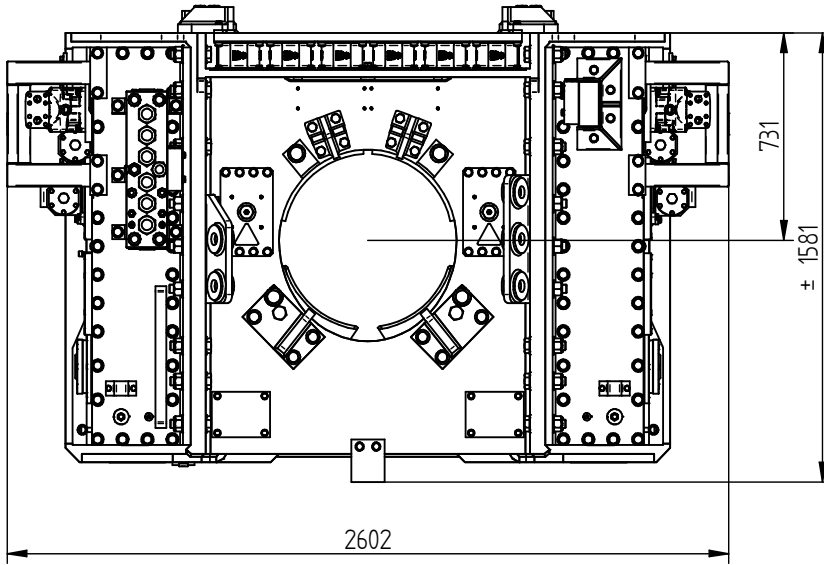

Technische Daten :

PVE 32VMR

Statisches Moment	32 kgm	Klemmzange:	
Max. Fliehkraft	1800 kN	Universalzange	N/A
Max. Drehzahl	2300 rpm	Transportgew. pro Stück	N/A kg
Max. Amplitude	5 mm	Rohrklemmzange	N/A
Max. Amplitude mit klemme	N/A mm	Transportgew. pro Stück	N/A kg
Max. Statische Zugkraft	400 kN		
Max. Betriebsdruck	350 bar	Aggregat:	
Max. Fördermenge	860 l/min	Modell	900 series
Zwangsschmierung	ja		
Dyn. Gewicht	12000 kg	Schlauchsatz:	
Dyn. Gewicht mit klemme	N/A kg	Länge	N/A m
Gesamtgew. Ohne Schläuche	12500 kg	Transportgewicht (±)	N/A kg

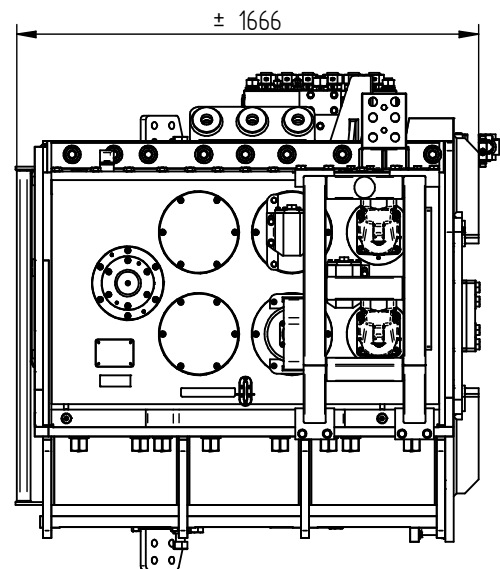
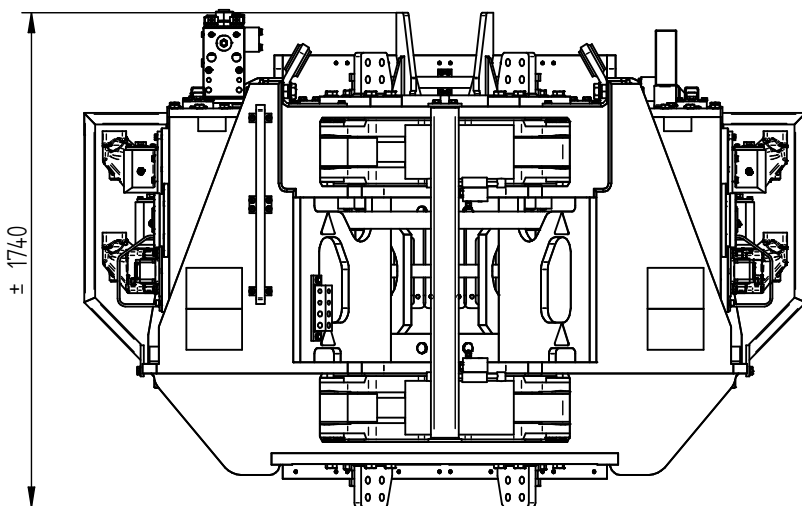
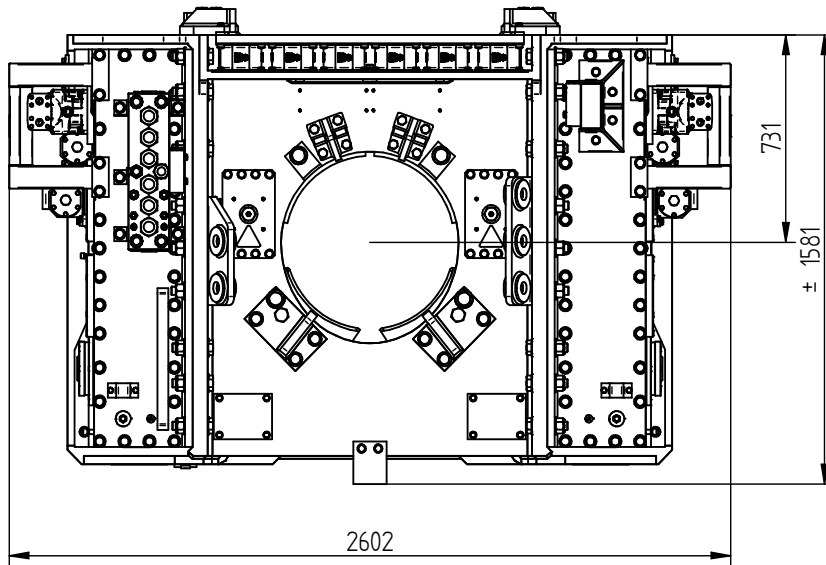

Spécifications

PVE 32VMR

Moment excentrique	32 kgm	Pinces:	
Max. force centrifuge	1800 kN	Pince palplanche	N/A
Max. fréquence	2300 rpm	Poids de transport par pièce	N/A kg
Max. amplitude	5 mm	Pince tube	N/A
Max. amplitude avec pince	N/A mm	Poids de transport par pièce	N/A kg
Force de traction statique	400 kN		
Pression de travail max.	350 bar	Groupe hydraulique:	
Débit d'huile max.	860 l/min	Modèle	900 series
Huile lubrifiante	oui		
Poids dynamique	12000 kg	Jeu de tuyau:	
Poids dynamique avec pince	N/A kg	Longueur	N/A m
Poids total sans tuyaux	12500 kg	Poids de transport (±)	N/A kg

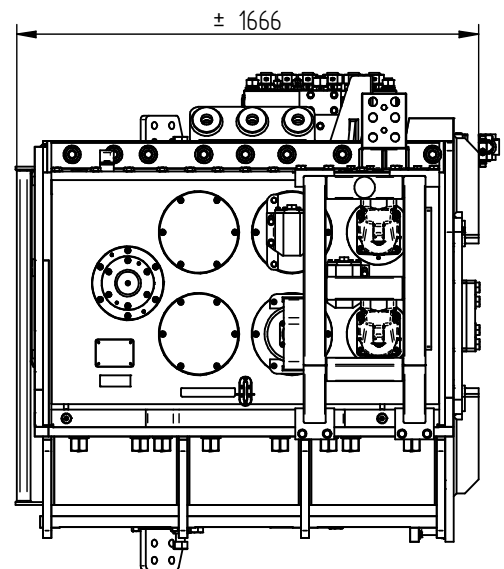
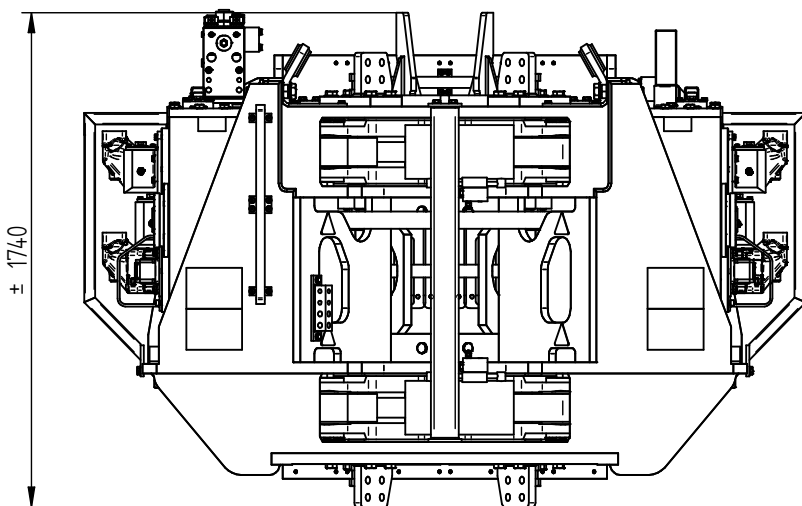
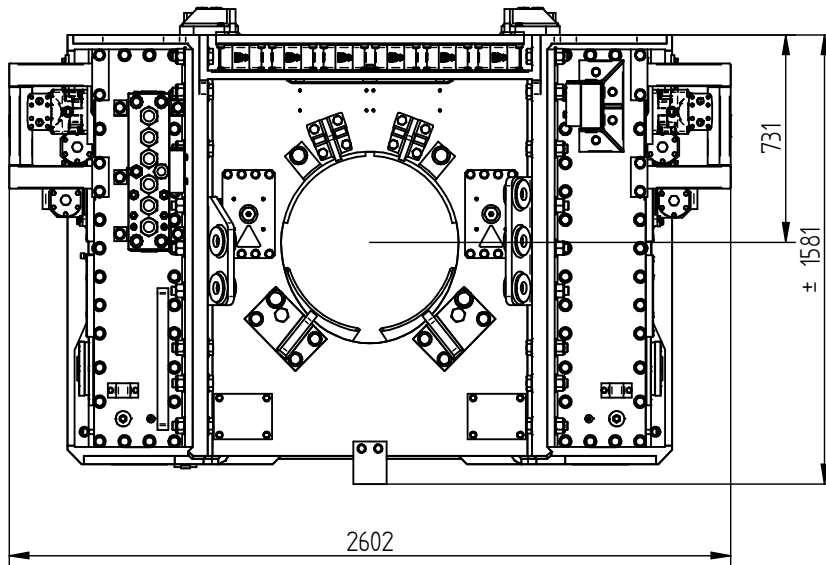

Specificaties

PVE 32VMR

Excentrisch moment	32 kgm	Klemmen:	
Max. centrifugaalkracht	1800 kN	Damwandklem	N/A
Max. toerental	2300 rpm	Transportgewicht per klem	N/A kg
Max. amplitude	5 mm	Pijpenklem	N/A
Max. amplitude incl. klem	N/A mm	Transportgewicht per klem	N/A kg
Max. statische trekkracht	400 kN		
Max. werkdruk	350 bar	Aggregaat:	
Max. oliedoorstroming	860 l/min	Model	900 series
Geforceerde smering	ja		
Dynamisch gewicht	12000 kg	Slangenset:	
Dynamisch gewicht incl. klem	N/A kg	Lengte	N/A m
Totaalgewicht excl. slangen	12500 kg	Transportgewicht (±)	N/A kg



Specificatii

PVE 32VMR

Ciocan vibrator

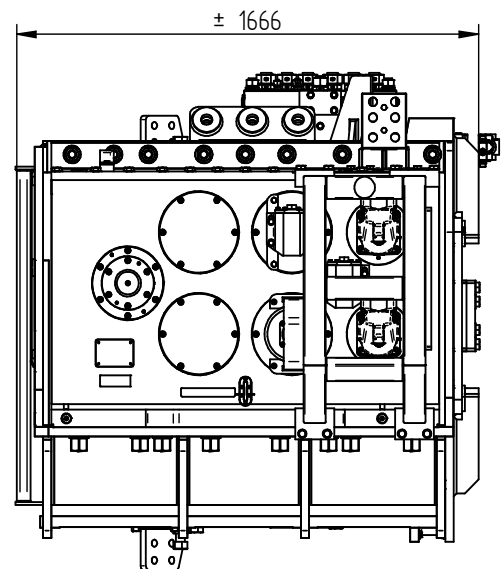
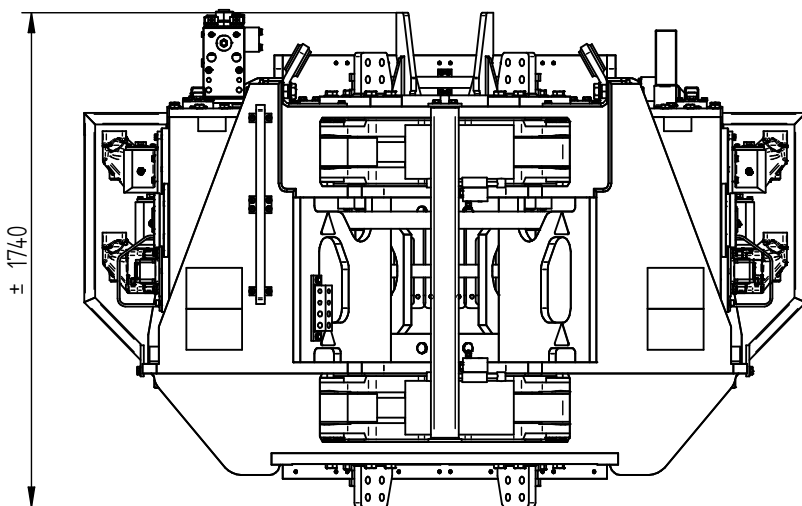
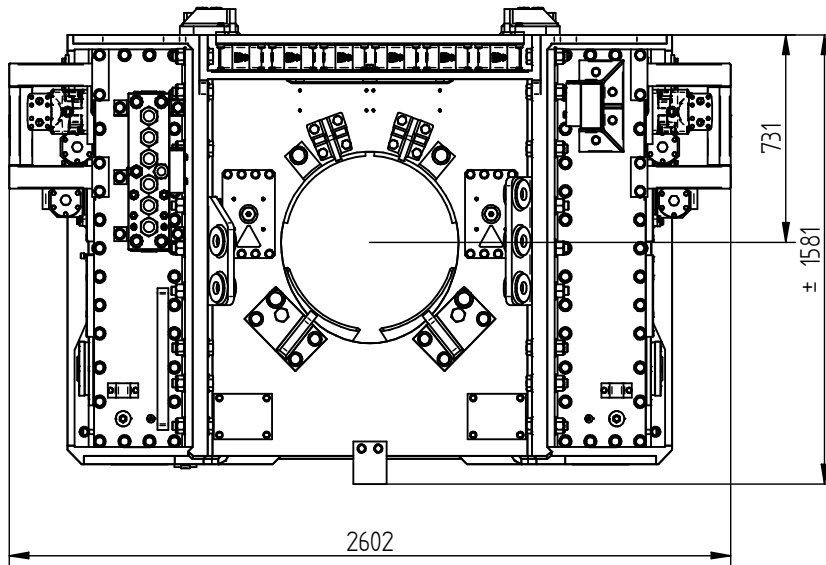
**Specificatii****PVE 32VMR**

Moment excentric	32 kgm	Menghina:	
Forta centrifuga maxima	1800 kN	Menghina pentru palplanse	N/A
Frecventa maxima	2300 rpm	Greutatea transportului pe buc.	N/A kg
Amplitudinea maxima	5 mm	Menghina dubla	N/A
Amplitudinea maxima inclusiv menghina	N/A mm	Greutatea transportului pe buc.	N/A kg
Tractiune statica maxima	400 kN		
Presiunea maxima de lucru	350 bar	Unitate de putere:	
Debit maxim de ulei	860 l/min	Model	900 series
Ungere fortata	da		
Greutate dinamica	12000 kg	Set furtun:	
Greutate dinamica inclusiv menghina	N/A kg	Lungime	N/A m
Greutate totala cu furtun atasat	12500 kg	Greutatea transportului (±)	N/A kg



Specifications

PVE 32VMR

Vibro Hammer

USA

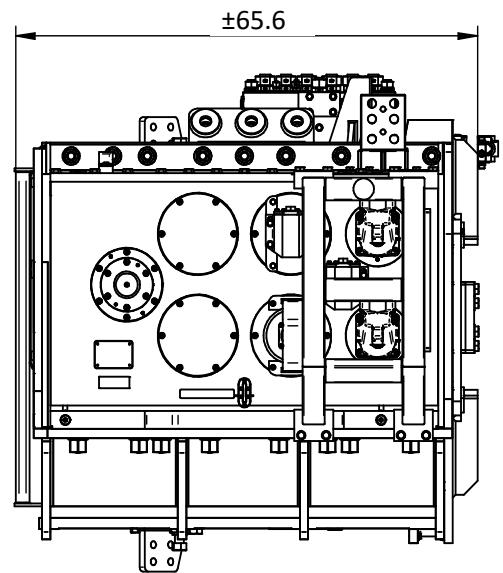
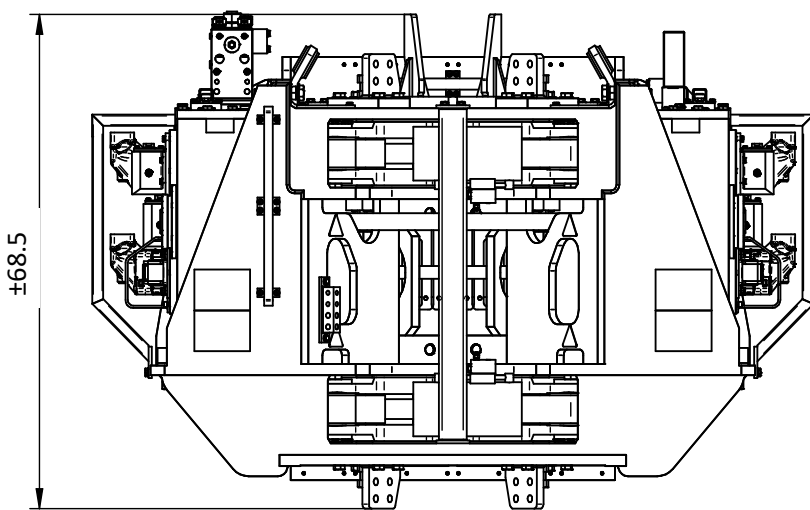
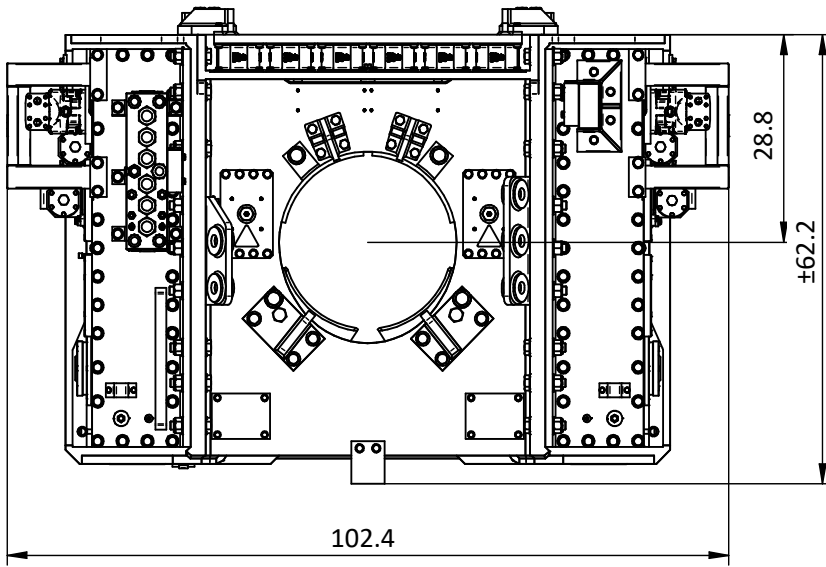

Specifications

PVE 32VMR

Eccentric moment	0-2777.8 lbs in	Clamps:	
Max. centrifugal force	0-202.3 US tn	Sheet pile clamp	N/A
Max. frequency	2300 rpm	Transport weight per piece	N/A lbs
Max. amplitude	0.20 in	Double clamps	N/A
Max. amplitude including clamp	N/A in	Transport weight per piece	N/A lbs
Max. static line-pull	40.8 US tn		
Max. operating pressure	5076 psi	Powerpack:	
Max. oil flow	227 gal/min	Model	900 series
Forced lubrication	yes		
Dynamic weight	26455 lbs	Hose set:	
Dynamic weight including clamp	N/A lbs	Length	N/A ft
Total weight excluding hoses	27558 lbs	Transport weight (±)	N/A lbs