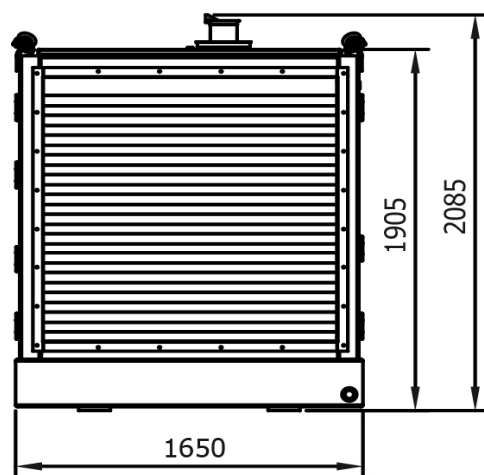
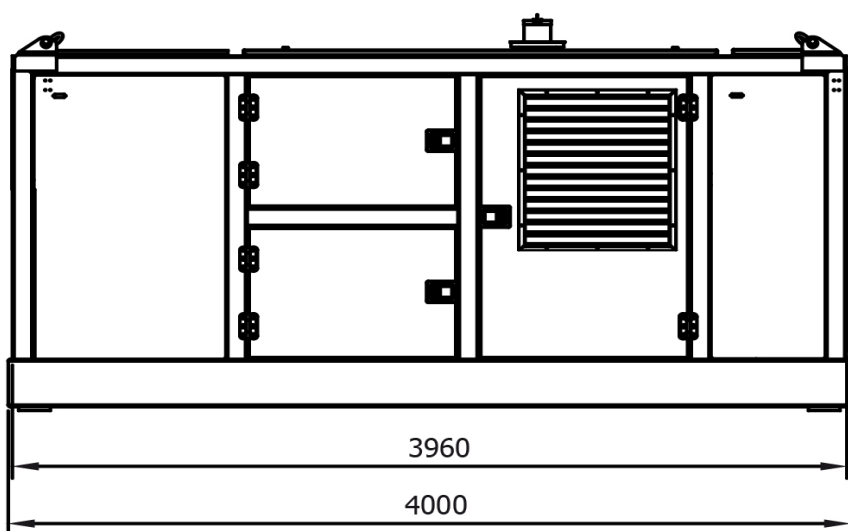
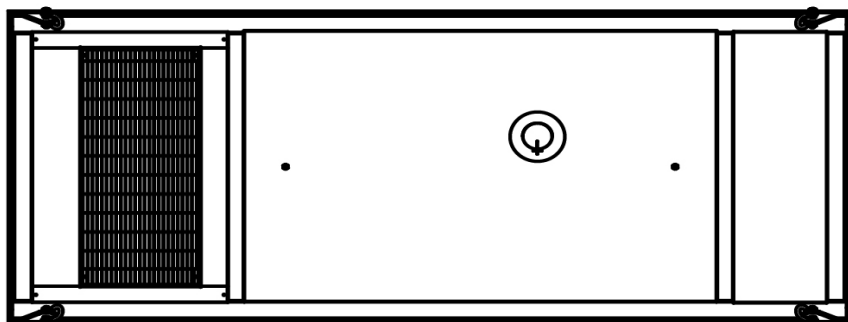

Specification sheet

PVE 400 STAGE IIIA / TIER 3

Hydraulic Power Pack

English

Specifications :
PVE 400 STAGE IIIA / TIER 3

Diesel Engine	CAT C9	
Max. theoretical power	242/329	kW/HP
Max. frequency	2200	rpm
Max. operating pressure	350	bar
Hydraulic pump	Parker	
Max. oil flow	396	L/min
Diesel oil	620	L
DEF (AdBlue) capacity	N.A.	L
Hydraulic oil	1050	L
Weight without fuel	5500	kg
Weight filled up	6000	kg



Technische Daten PVE 400 STAGE IIIA / TIER 3

Aggregat

Deutsch

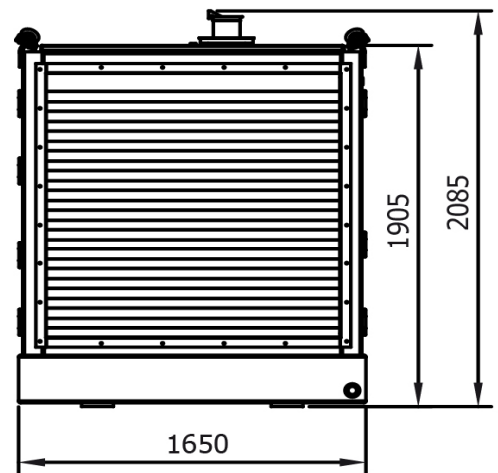
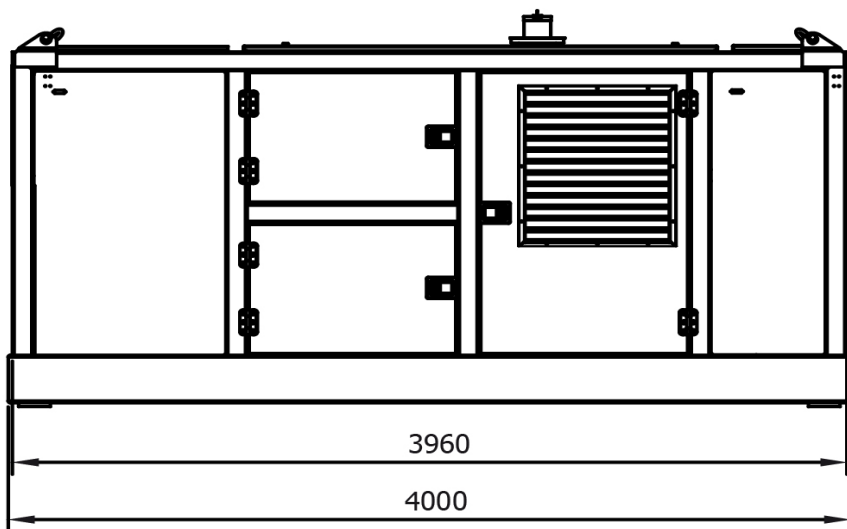
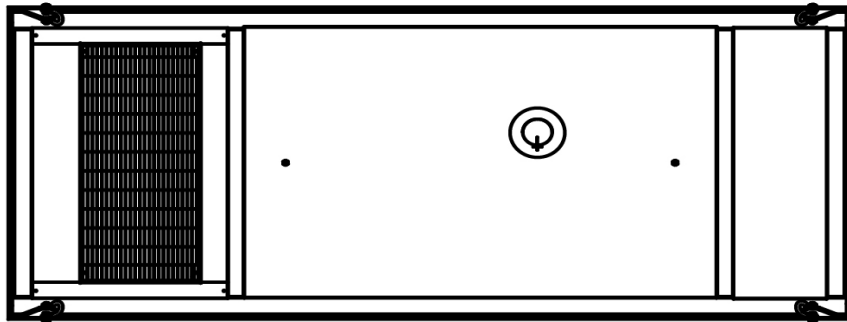
**Technische Daten :****PVE 400 STAGE IIIA / TIER 3**

Dieselmotor	CAT C9	
Max. theoretische Leistung	242/329	kW/HP
Max. Drehzahl	2200	rpm
Max. Betriebsdruck	350	bar
Hydraulische Pumpe	Parker	
Max. Fördermenge	396	L/min
Diesel Öl	620	L
DAF (AdBlue) kapazität	N.A.	L
Hydraulische Öl	1050	L
Gewicht ohne Diesel Öl	5500	kg
Gewicht	6000	kg

Spécifications

PVE 400 STAGE IIIA / TIER 3

Groupe hydraulique

Français

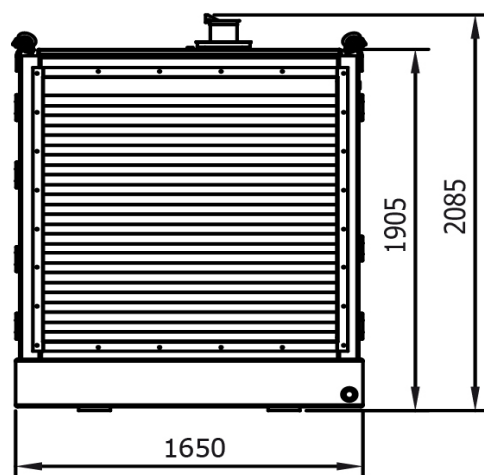
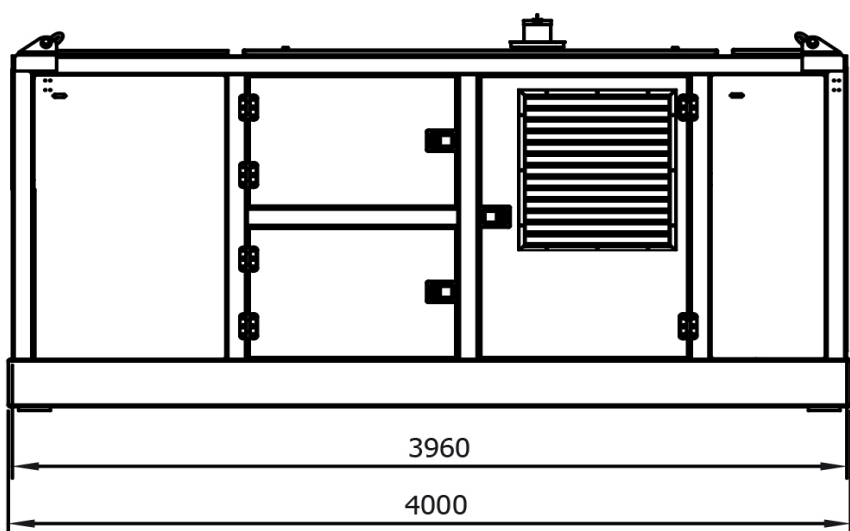
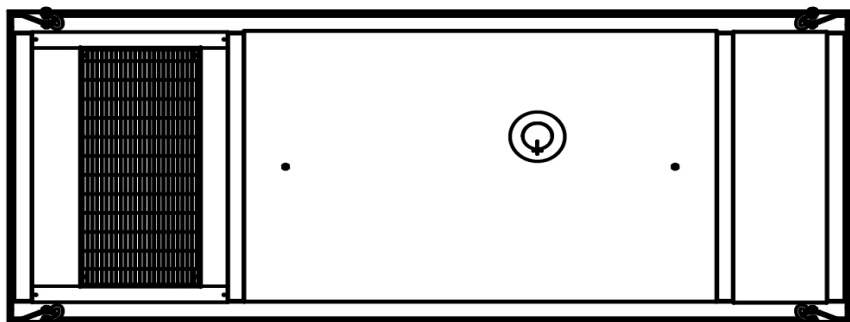

Spécifications

PVE 400 STAGE IIIA / TIER 3

Moteur Diesel	CAT C9	
Puissance théorique max.	242/329	kW/HP
Max. fréquence	2200	rpm
Pression de travail max.	350	bar
Pompe hydraulique	Parker	
Débit d'huile max.	396	L/min
Huile diesel	620	L
Capacité FED (AdBlue)	N.A.	L
Huile hydraulique	1050	L
Poids sans huile diesel	5500	kg
Poids	6000	kg



Specificaties PVE 400 STAGE IIIA / TIER 3

Hydraulisch aggregaat

Nederlands

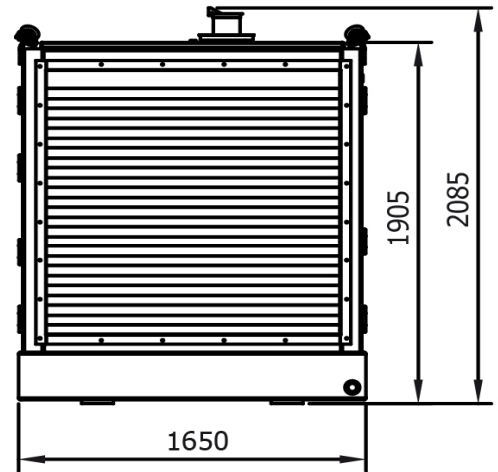
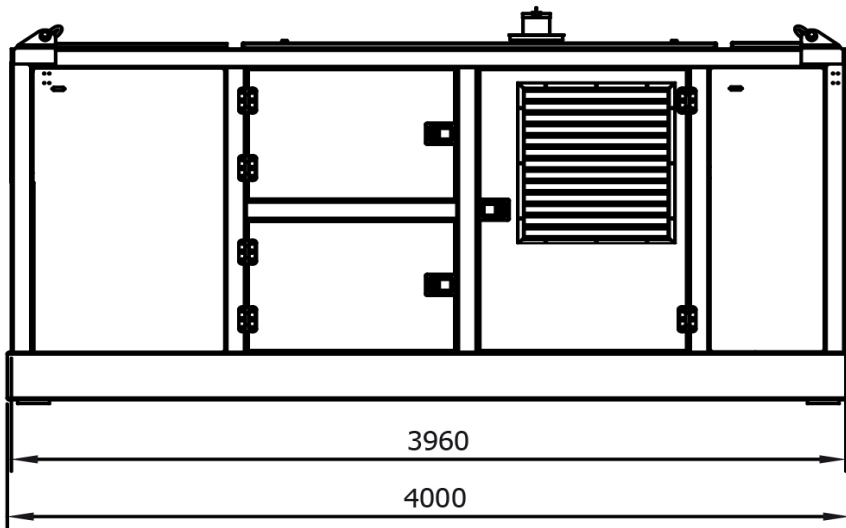
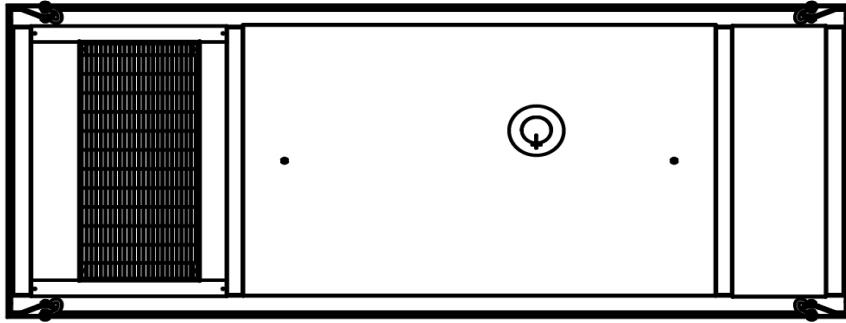

Specificaties

PVE 400 STAGE IIIA / TIER 3

Dieselmotor	CAT C9	
Max. theoretisch vermogen	242/329	kW/HP
Max. toerental	2200	rpm
Max. werkdruk	350	bar
Hydraulische pomp	Parker	
Max. olie doorstroming	396	L/min
Diesel olie	620	L
DEF (AdBlue) capaciteit	N.A.	L
Hydraulische olie	1050	L
Gewicht zonder diesel	5500	kg
Gewicht	6000	kg

Specificatii

PVE 400 STAGE IIIA / TIER 3

Unitate de putere hidraulica

Español

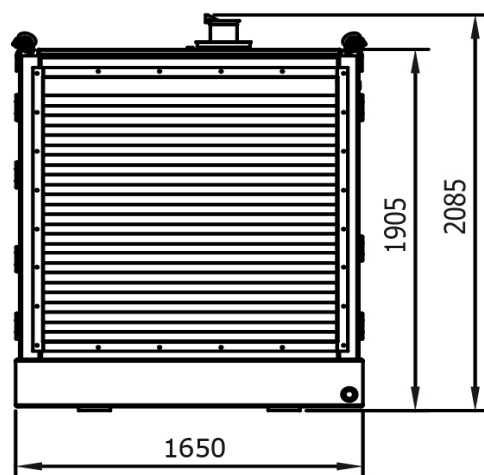
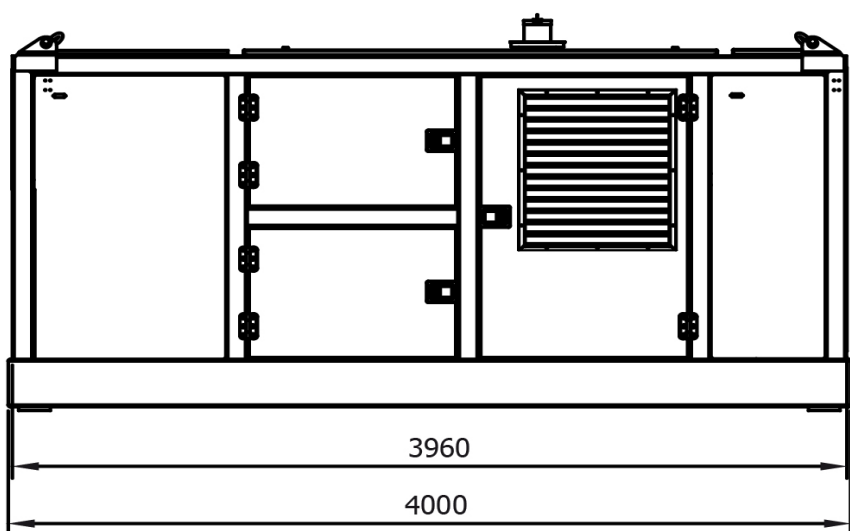
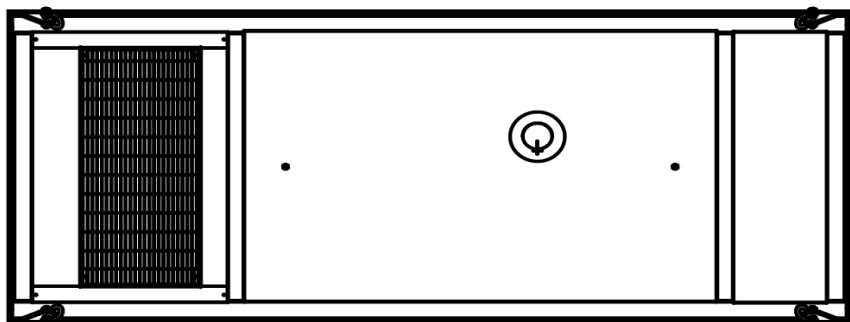

Specificatii

PVE 400 STAGE IIIA / TIER 3

Motor Diesel	CAT C9	
Putere max. teoretica	242/329	kW/HP
Frecventa max.	2200	rpm
Presiune maxima de lucru	350	bar
Pompa hidraulica	Parker	
Debit max. de ulei	396	L/min
Ulei Diesel	620	L
Capacitate rezervor aditiv AdBlue	N.A.	L
Ulei hidraulic	1050	L
Greutate fara ulei	5500	kg
Greutate	6000	kg



Specifications

PVE 400 STAGE IIIA / TIER 3

Hydraulic Power Pack

USA

Dimensions in inches

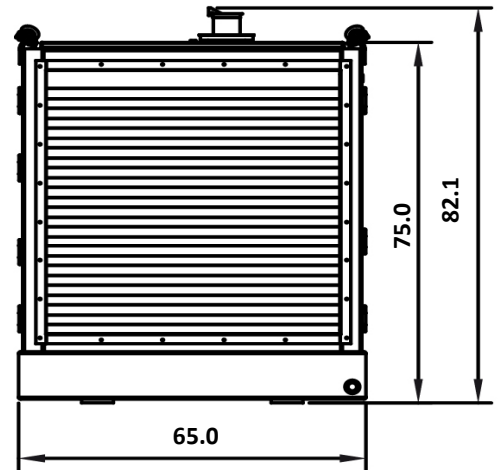
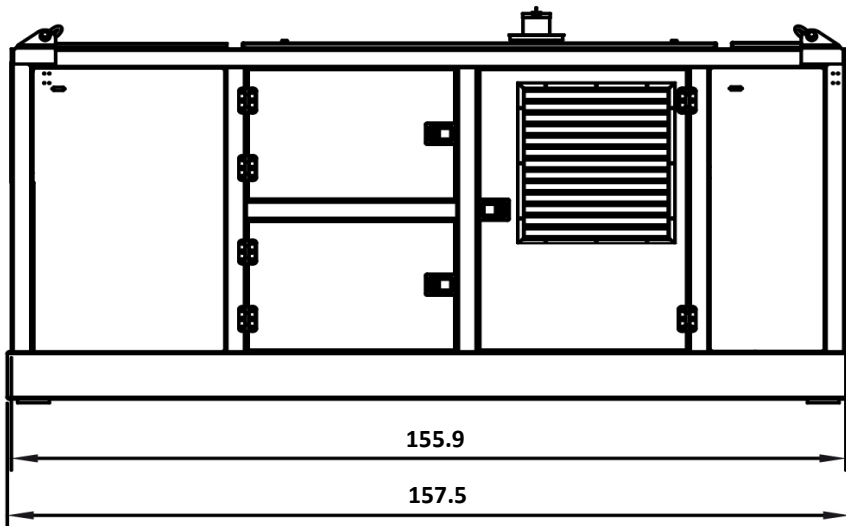
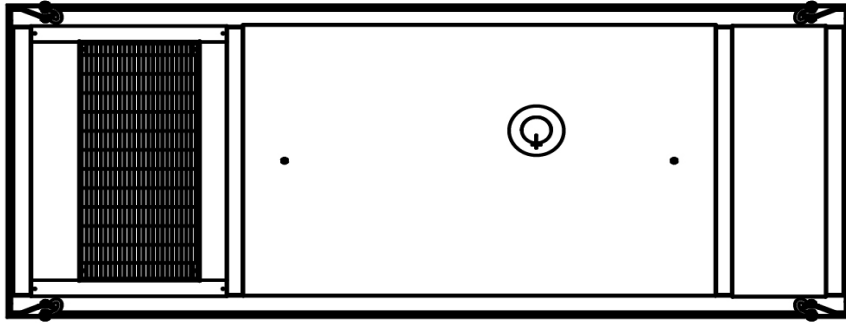

Specifications

PVE 400 STAGE IIIA / TIER 3

Diesel Engine	CAT C9	
Max. theoretical power	242/329	kW/HP
Max. frequency	2,200	rpm
Max. operating pressure	5,076	psi
Hydraulic pump	Parker	
Max. oil flow	105	gal/min
Diesel Fuel	164	gal
DEF (AdBlue) capacity	N.A.	gal
Hydraulic oil	277	gal
Weight without fuel	12,125	lbs
Weight with fuel	13,228	lbs