

Specifications :
PVE 400 STAGE V

Diesel Engine	Volvo TAD 884 VE	
Max. theoretical power	250/340	kW/HP
Max. frequency	2200	rpm
Max. operating pressure	350	bar
Hydraulic pump	Parker	
Max. oil flow	396	L/min
Diesel oil	530	L
DEF (AdBlue) capacity	25	L
Hydraulic oil	800	L
Weight without fuel	4700	kg
Weight filled up	5150	kg

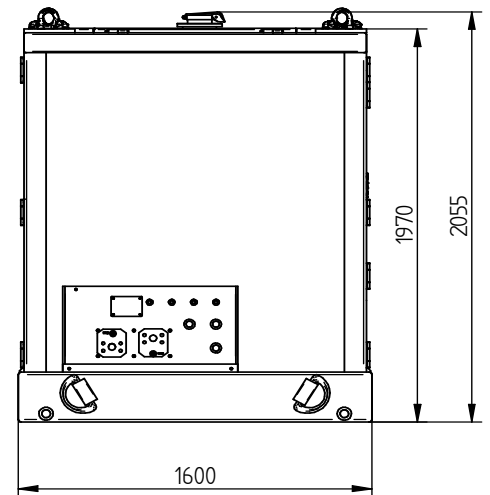
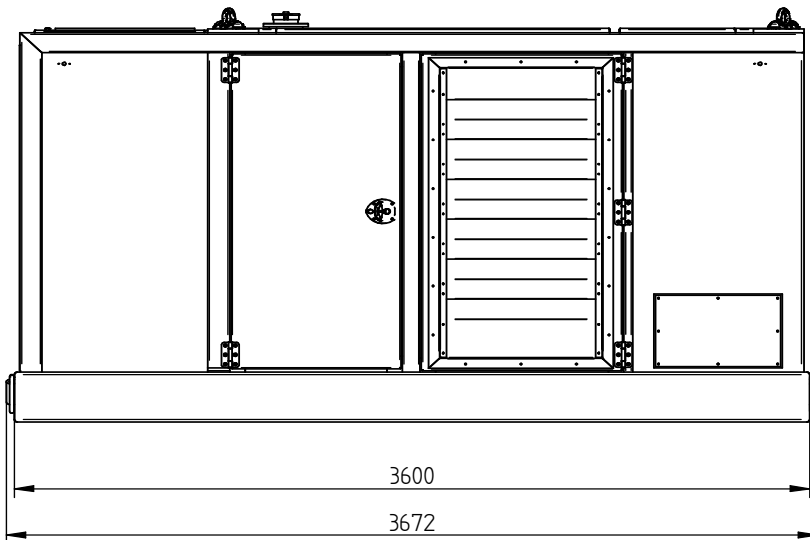
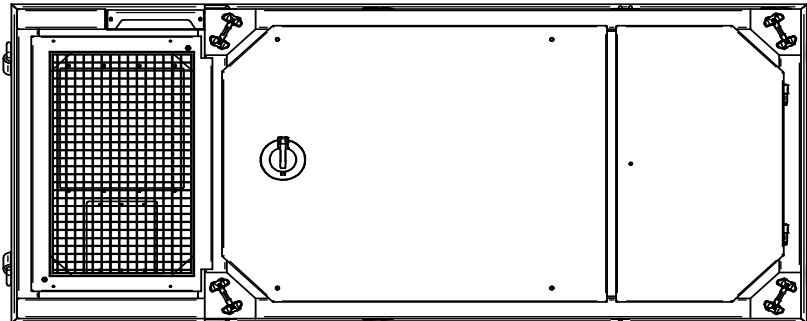

Technische Daten :

PVE 400 STAGE V

Dieselmotor	Volvo TAD 884 VE	
Max. theoretische Leistung	250/340	kW/HP
Max. Drehzahl	2200	rpm
Max. Betriebsdruck	350	bar
Hydraulische Pumpe	Parker	
Max. Fördermenge	396	L/min
Diesel Öl	530	L
DAF (AdBlue) kapazität	25	L
Hydraulische Öl	800	L
Gewicht ohne Diesel Öl	4700	kg
Gewicht	5150	kg

Spécifications

PVE 400 STAGE V

Groupe hydraulique

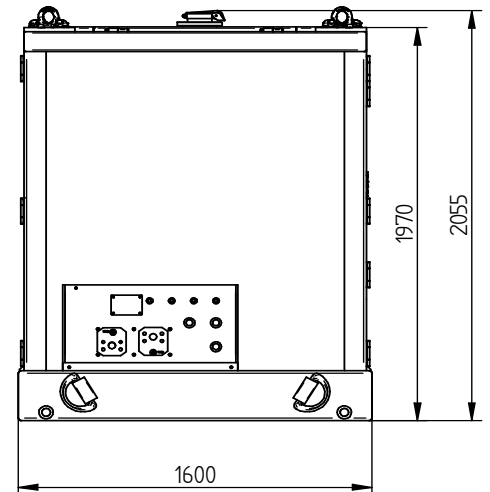
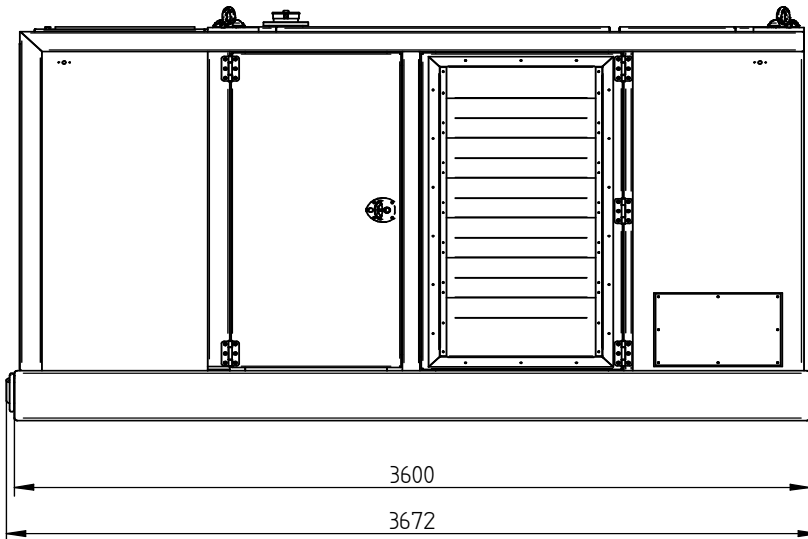
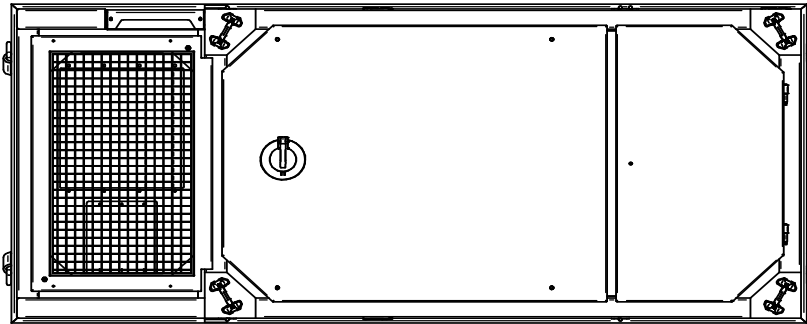

Spécifications

PVE 400 STAGE V

Moteur Diesel	Volvo TAD 884 VE	
Puissance théorique max.	250/340	kW/HP
Max. fréquence	2200	rpm
Pression de travail max.	350	bar
Pompe hydraulique	Parker	
Débit d'huile max.	396	L/min
Huile diesel	530	L
Capacité FED (AdBlue)	25	L
Huile hydraulique	800	L
Poids sans huile diesel	4700	kg
Poids	5150	kg

Specificaties

PVE 400 STAGE V

Hydraulisch aggregaat

Nederlands

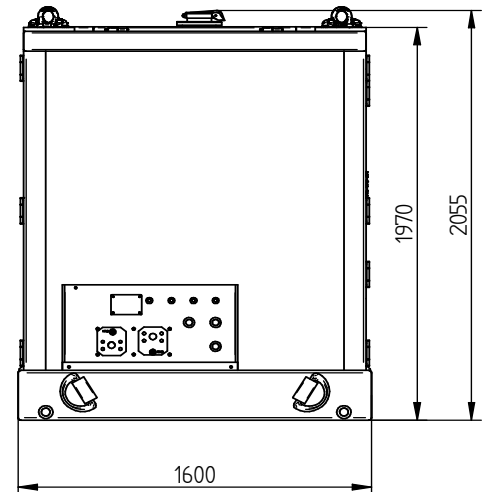
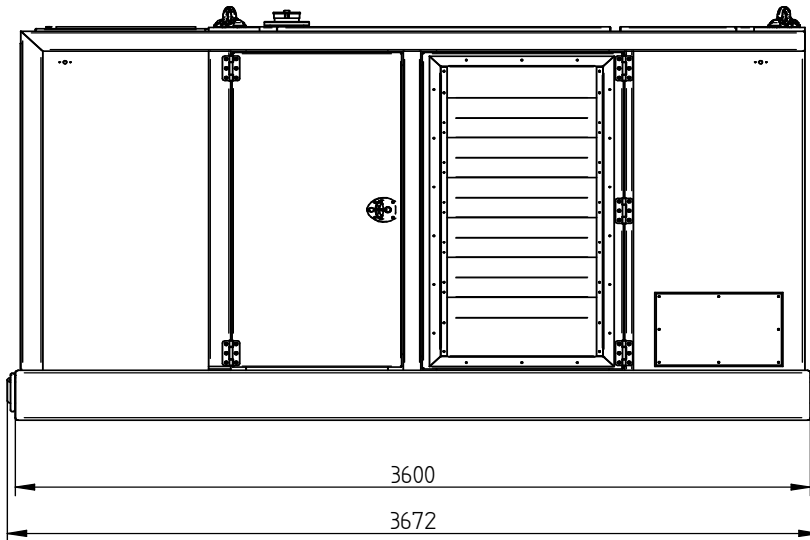
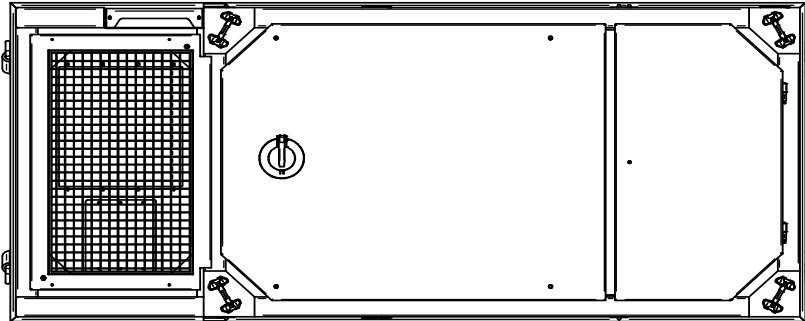

Specificaties

PVE 400 STAGE V

Dieselmotor	Volvo TAD 884 VE	
Max. theoretisch vermogen	250/340	kW/HP
Max. toerental	2200	rpm
Max. werkdruk	350	bar
Hydraulische pomp	Parker	
Max. olie doorstroming	396	L/min
Diesel olie	530	L
DEF (AdBlue) capaciteit	25	L
Hydraulische olie	800	L
Gewicht zonder diesel	4700	kg
Gewicht	5150	kg

Specificatii

PVE 400 STAGE V

Unitate de alimentare

Español

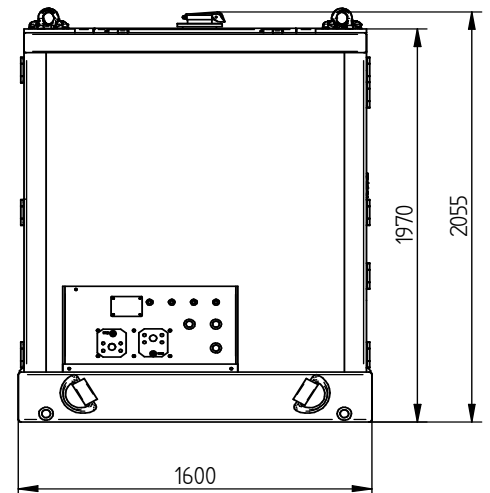
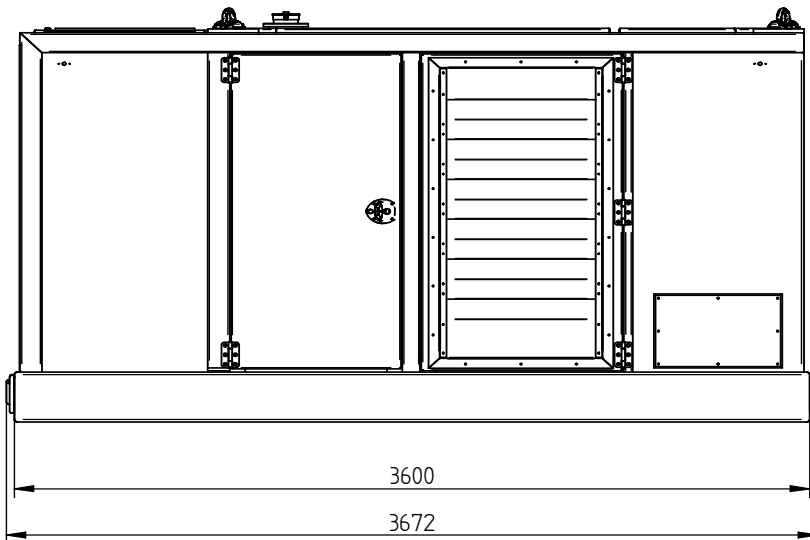
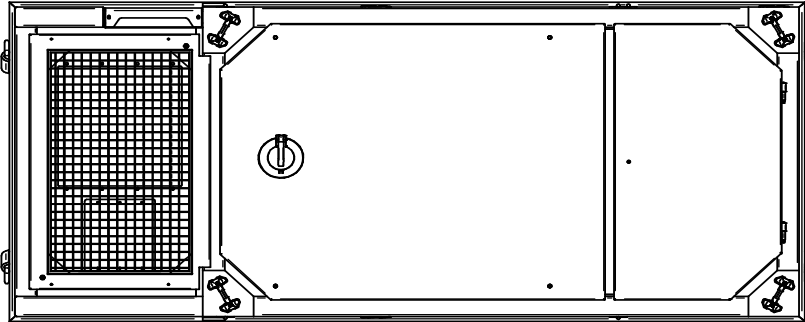

Specificatii

PVE 400 STAGE V

Motor diesel	Volvo TAD 884 VE	
Putere max. teoretica	250/340	kW/HP
Frecventa max.	2200	rpm
Presiune maxima de lucru	350	bar
Pompa hidraulica	Parker	
Debit max. de ulei	396	L/min
Ulei Diesel	530	L
Capacitate DEF (AdBlue)	25	L
Ulei hidraulic	800	L
Greutate fara ulei	4700	kg
Greutate umpluta	5150	kg

Specifications

PVE 400 STAGE V

Hydraulic Power Pack

USA

Dimensions in inches

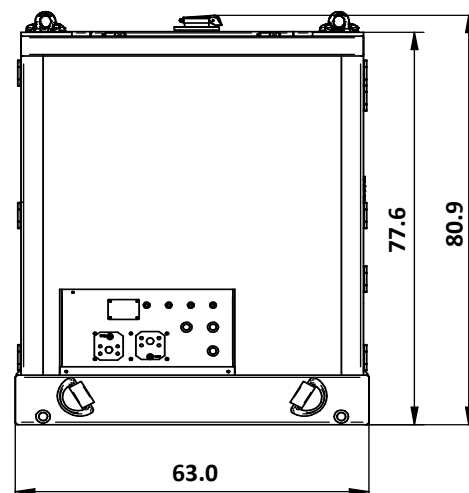
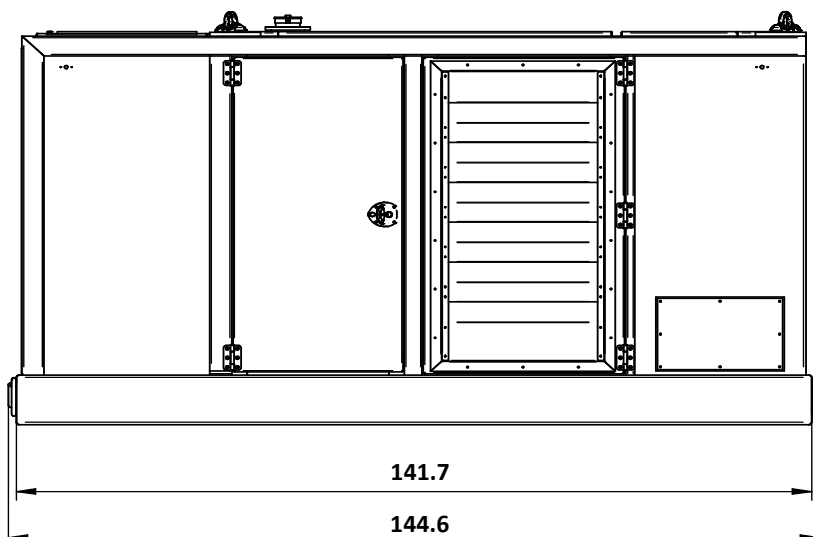
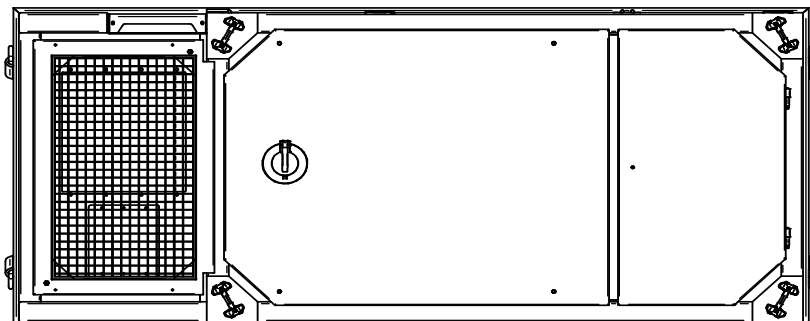

Specifications

PVE 400 STAGE V

Diesel Engine	Volvo TAD 884 VE	
Max. theoretical power	250/340	kW/HP
Max. frequency	2,200	rpm
Max. operating pressure	5,076	psi
Hydraulic pump	Parker	
Max. oil flow	105	gal/min
Diesel Fuel	140	gal
DEF (AdBlue) capacity	7	gal
Hydraulic oil	211	gal
Weight without fuel	10,362	lbs
Weight with fuel	11,354	lbs