

Specifications :

ICE 55NF

Eccentric moment	54 kgm	Clamps:	
Max. centrifugal force	1711 kN	Sheet pile clamp	200TU
Max. frequency	1700 rpm	Transport weight per piece	1300 kg
Max. amplitude excl. 200TU	30.1 mm	Double clamps	100TC
Max. amplitude incl. 200TU	22.13 mm	Transport weight per piece	690 kg
Max. static line-pull	800 kN		
Max. operating pressure	350 bar	Powerpack:	
Max. oil flow	617 l/min	Model	600 series
Forced lubrication	yes		
Dynamic weight excl. 200TU	3580 kg	Hose set:	
Dynamic weight incl. 200TU	4880 kg	Length	45 m
Total weight excl. 200TU & hoses	5700 kg	Transport weight (±)	1100 kg

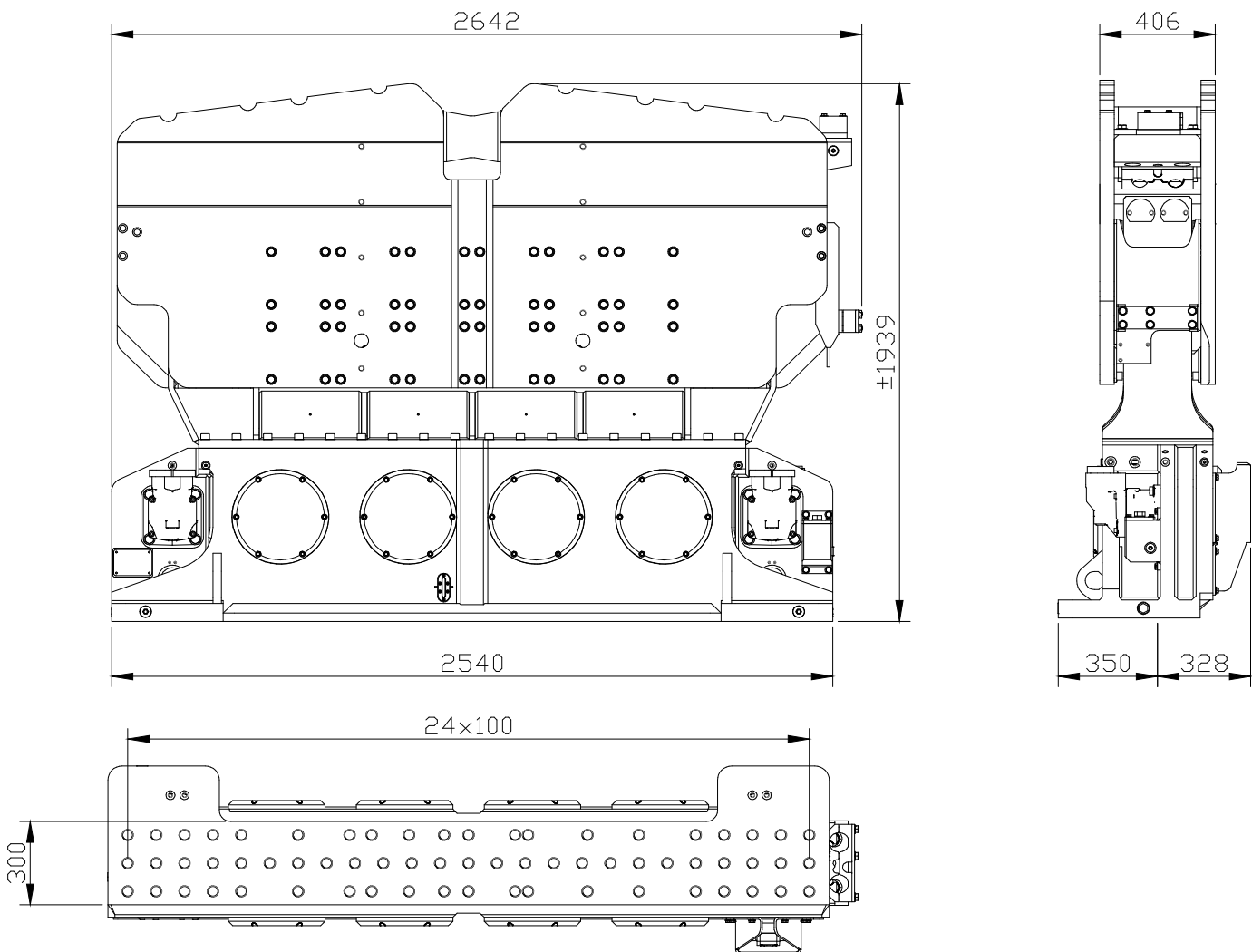

Technische Daten :

ICE 55NF

Statisches Moment	54 kgm	Klemmzange:	
Max. Fliehkraft	1711 kN	Universalzange	200TU
Max. Drehzahl	1700 rpm	Transportgew. pro Stück	1300 kg
Max. Amplitude ohne 100TU	30.1 mm	Rohrklemmzange	100TC
Max. Amplitude mit 100TU	22.13 mm	Transportgew. pro Stück	690 kg
Max. Statische Zugkraft	800 kN		
Max. Betriebsdruck	350 bar	Aggregat:	
Max. Fördermenge	617 l/min	Modell	600 series
Zwangsschmierung	ja		
Dyn. Gewicht ohne 100TU	3580 kg	Schlauchsatz:	
Dyn. Gewicht mit 100TU	4880 kg	Länge	45 m
Gesamtgew. ohne 100TU & Schläuche	5700 kg	Transportgewicht (±)	1100 kg

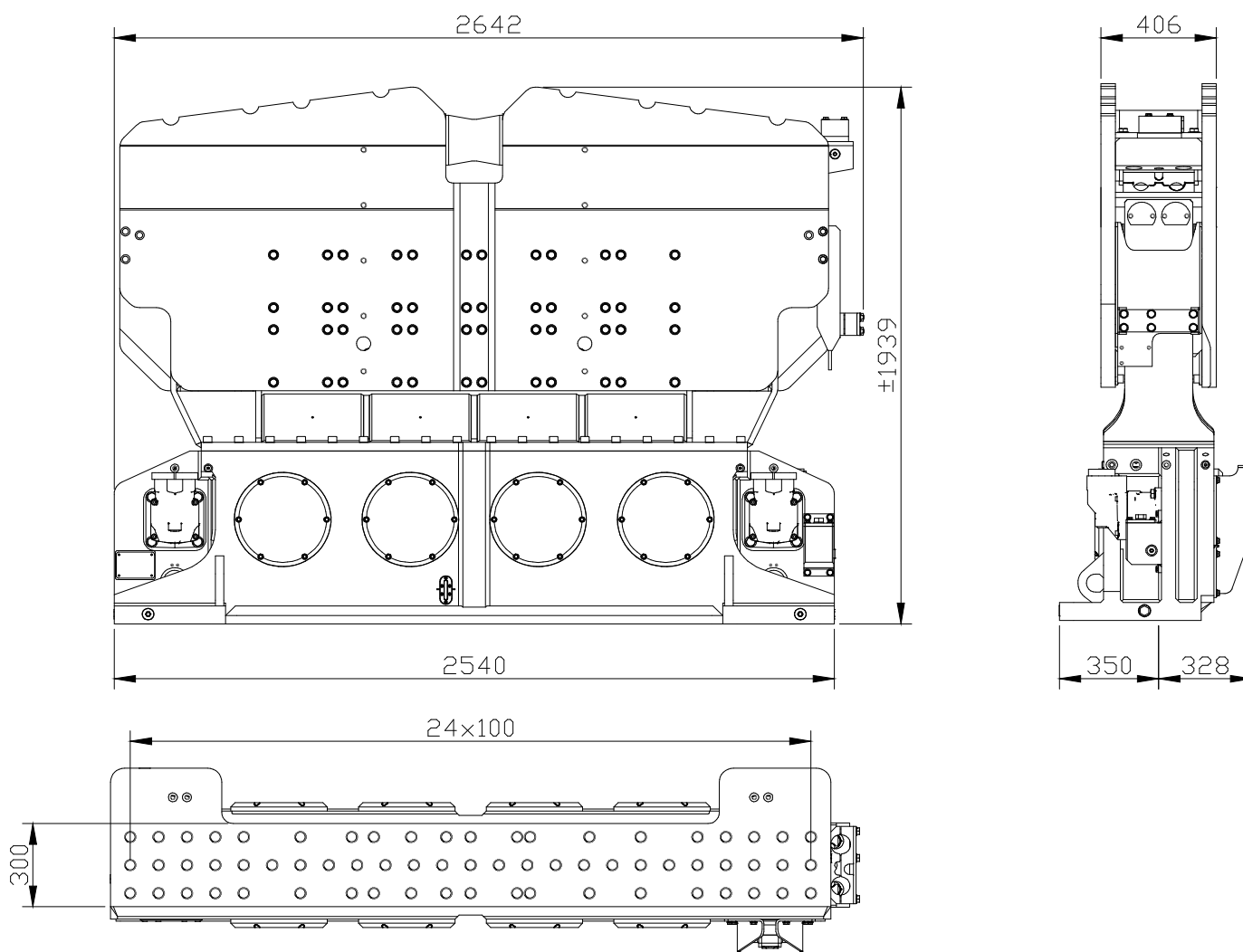

Spécifications

ICE 55NF

Moment excentrique	54 kgm	Pinces:	
Max. force centrifuge	1711 kN	Pince palplanche	200TU
Max. fréquence	1700 rpm	Poids de transport par pièce	1300 kg
Max. amplitude sans 100TU	30.1 mm	Pince tube	100TC
Max. amplitude avec 100TU	22.13 mm	Poids de transport par pièce	690 kg
Force de traction statique	800 kN		
Pression de travail max.	350 bar	Groupe hydraulique:	
Débit d'huile max.	617 l/min	Modèle	600 series
Huile lubrifiante	oui		
Poids dynamique sans 100TU	3580 kg	Jeu de tuyau:	
Poids dynamique avec 100TU	4880 kg	Longueur	45 m
Poids total sans 100TU & tuyaux	5700 kg	Poids de transport (±)	1100 kg

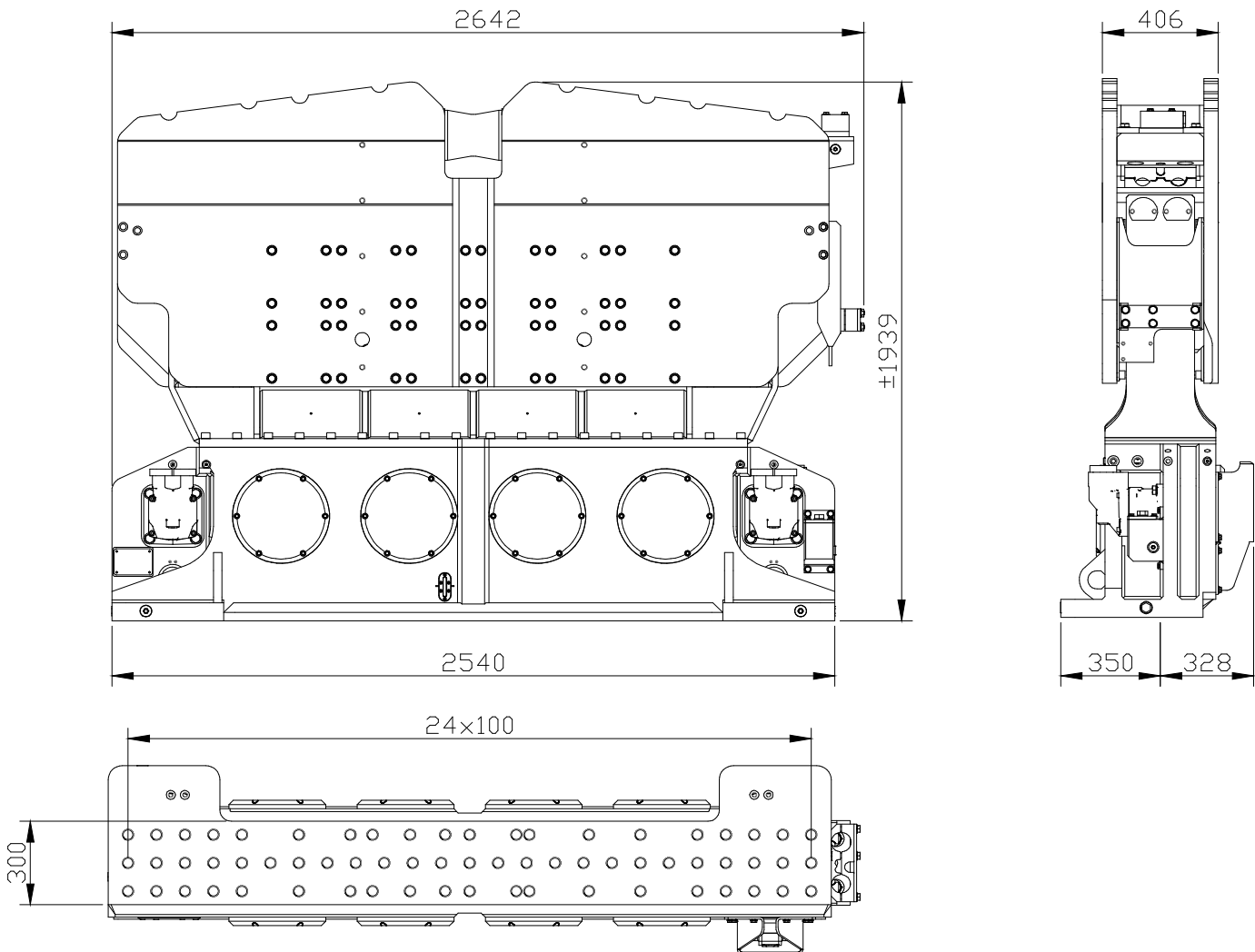

Specificaties

ICE 55NF

Excentrisch moment	54 kgm	Klemmen:	
Max. centrifugaalkracht	1711 kN	Damwandklem	200TU
Max. toerental	1700 rpm	Transportgewicht per klem	1300 kg
Max. amplitude excl. 100TU	30.1 mm	Pijpenklem	100TC
Max. amplitude incl. 100TU	22.13 mm	Transportgewicht per klem	690 kg
Max. statische trekkracht	800 kN		
Max. werkdruk	350 bar	Aggregaat:	
Max. oliedoorstroming	617 l/min	Model	600 series
Geforceerde smering	ja		
Dynamisch gewicht excl. 100TU	3580 kg	Slangenset:	
Dynamisch gewicht incl. 100TU	4880 kg	Lengte	45 m
Totaalgewicht excl. 100TU & slangen	5700 kg	Transportgewicht (±)	1100 kg

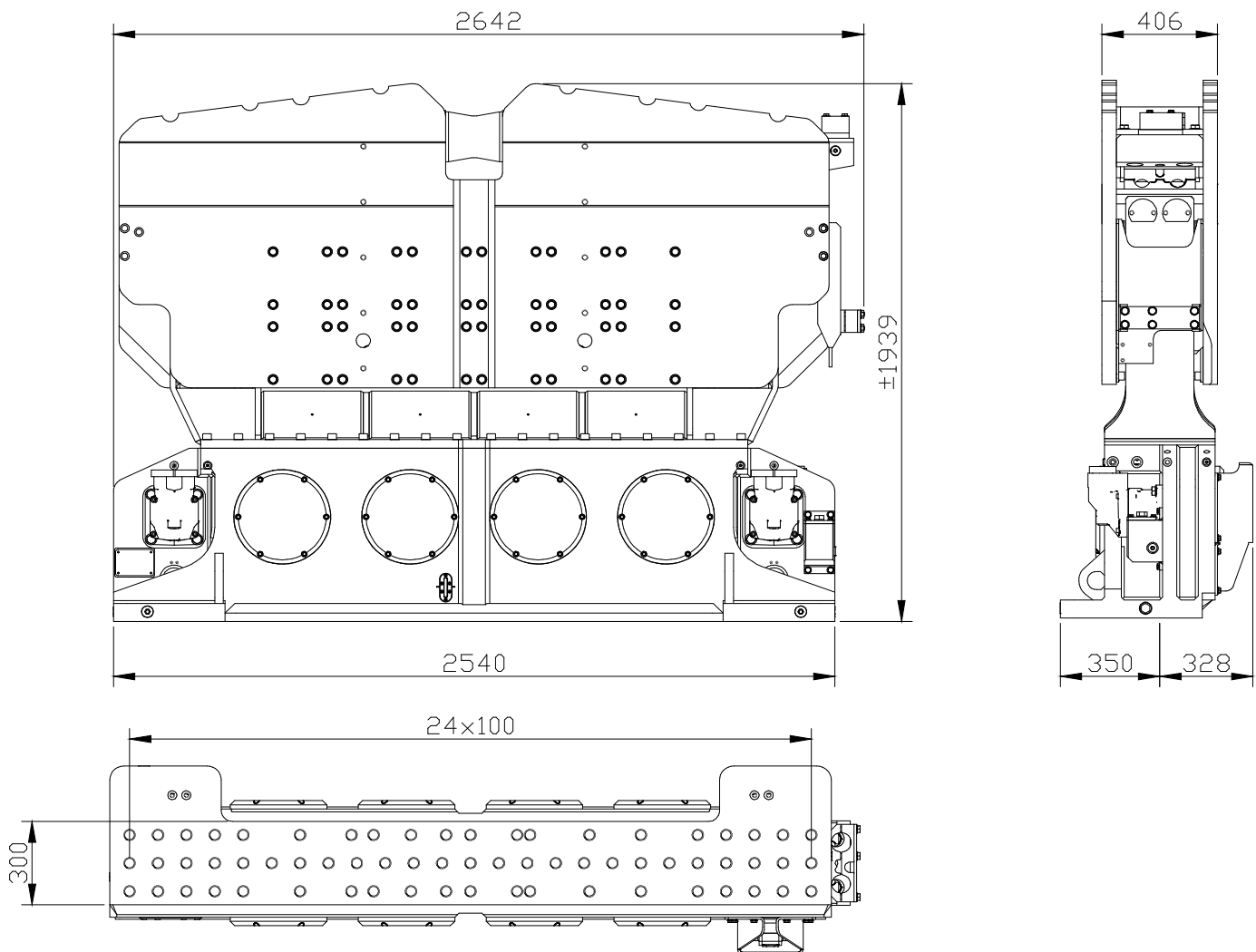

Specificatii

ICE 55NF

Moment excentric	54 kgm	Menghina:	
Forta centrifuga maxima	1711 kN	Menghina pentru palplanse	200TU
Frecventa maxima	1700 rpm	Greutatea transportului pe buc.	1300 kg
Amplitudinea maxima excluzand 100TU	30.1 mm	Menghina dubla	100TC
Amplitudinea maxima inclusiv 100TU	22.13 mm	Greutatea transportului pe buc.	690 kg
Tractiune statica maxima	800 kN		
Presiunea maxima de lucru	350 bar	Unitate de putere:	
Debit maxim de ulei	617 l/min	Model	600 series
Ungere fortata	da		
Greutate dinamica excluzand 100TU	3580 kg	Set furtun:	
Greutate dinamica inclusiv 100TU	4880 kg	Lungime	45 m
Greutate totala excl. 100TU & furtunuri	5700 kg	Greutatea transportului (±)	1100 kg

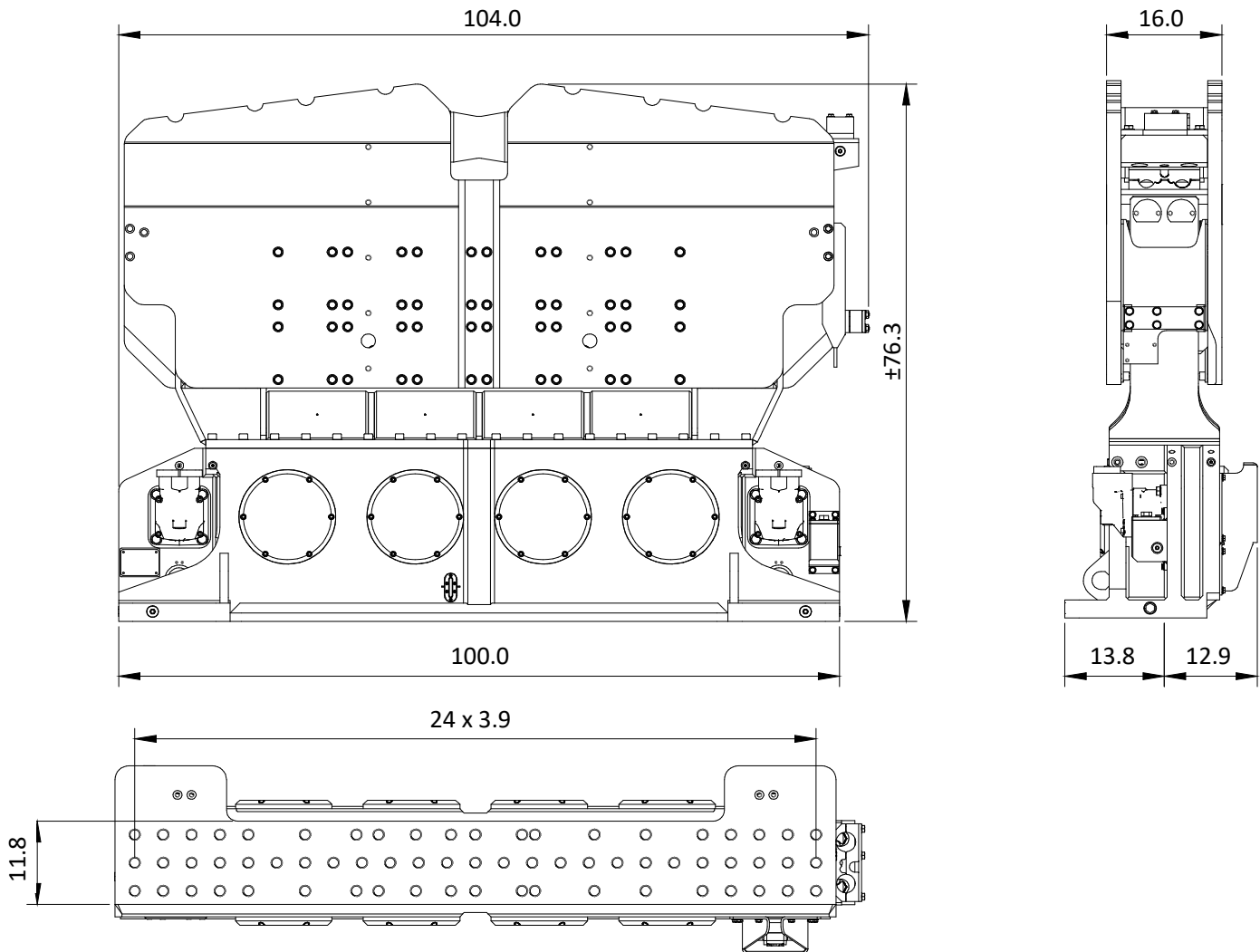

Specifications

ICE 55NF

Eccentric moment	0-4687.5 lbs in	Clamps:	
Max. centrifugal force	0-192.3 US tn	Sheet pile clamp	200TU
Max. frequency	1700 rpm	Transport weight per piece	2866 lbs
Max. amplitude excluding 100TU	1.19 in	Double clamps	100TC
Max. amplitude including 100TU	0.87 in	Transport weight per piece	1521 lbs
Max. static line-pull	81.6 US tn		
Max. operating pressure	5076 psi	Powerpack:	
Max. oil flow	163 gal/min	Model	600 series
Forced lubrication	yes		
Dynamic weight excluding 100TU	7893 lbs	Hose set:	
Dynamic weight including 100TU	10759 lbs	Length	148 ft
Total weight excluding 100TU & hoses	12566 lbs	Transport weight (±)	2425 lbs