

Specifications :

ICE 8RFSH

Eccentric moment	0 - 7.5 kgm	Clamps:	
Max. centrifugal force	0 - 435 kN	Sheet pile clamp	60TU
Max. frequency	2300 rpm	Transport weight per piece	250 kg
Max. amplitude excl. 60TU	14.9 mm	Double clamps	N/A
Max. amplitude incl. 60TU	12 mm	Transport weight per piece	N/A kg
Max. static line-pull	120 kN		
Max. operating pressure	350 bar	Powerpack:	
Max. oil flow	185 l/min	Model	N/A
Forced lubrication	yes		
Dynamic weight excl. 60TU	1005 kg	Hose set:	
Dynamic weight incl. 60TU	1255 kg	Length	N/A m
Total weight excl. 60TU & hoses	1930 kg	Transport weight (±)	N/A kg

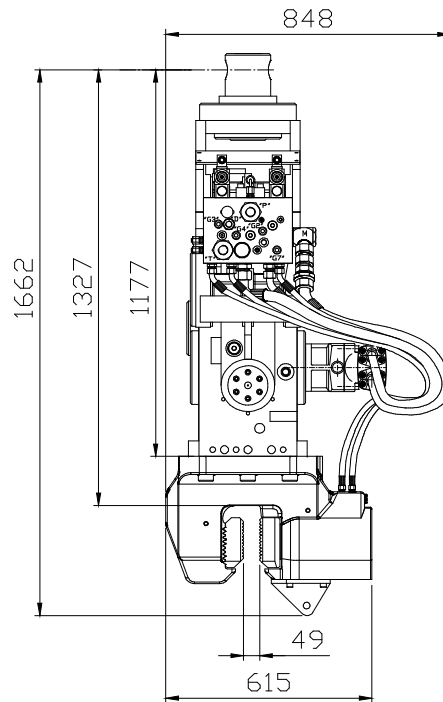
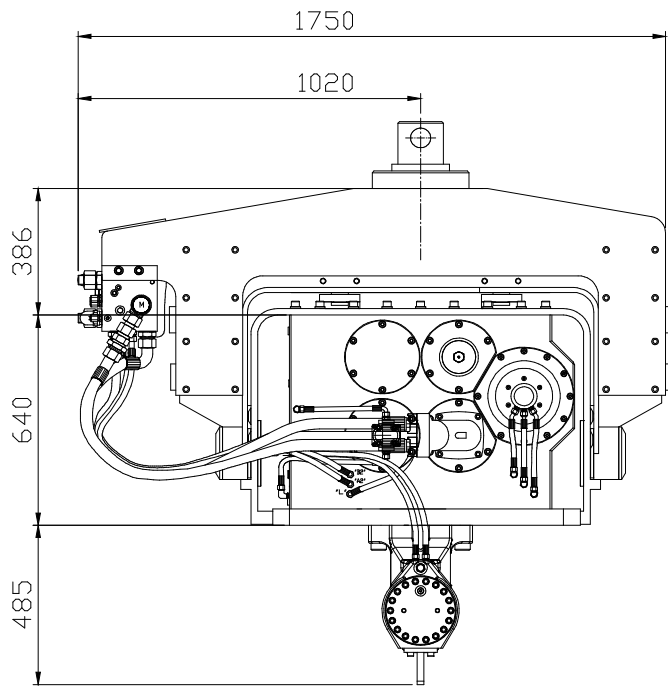

Technische Daten :

ICE 8RFSH

Statisches Moment	0 - 7.5 kgm	Klemmzange:	
Max. Fliehkraft	0 - 435 kN	Universalzange	60TU
Max. Drehzahl	2300 rpm	Transportgew. pro Stück	250 kg
Max. Amplitude ohne 60TU	14.9 mm	Rohrklemmzange	N/A
Max. Amplitude mit 60TU	12 mm	Transportgew. pro Stück	N/A kg
Max. Statische Zugkraft	120 kN		
Max. Betriebsdruck	350 bar	Aggregat:	
Max. Fördermenge	185 l/min	Modell	N/A
Zwangsschmierung	ja		
Dyn. Gewicht ohne 60TU	1005 kg	Schlauchsatz:	
Dyn. Gewicht mit 60TU	1255 kg	Länge	N/A m
Gesamtgew. ohne 60TU & Schläuche	1930 kg	Transportgewicht (±)	N/A kg

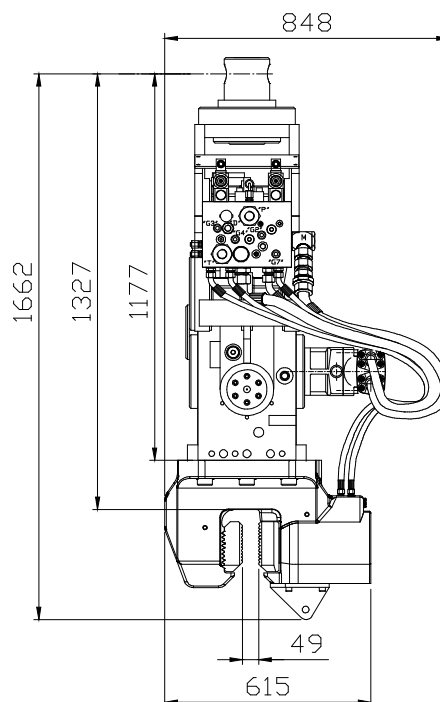
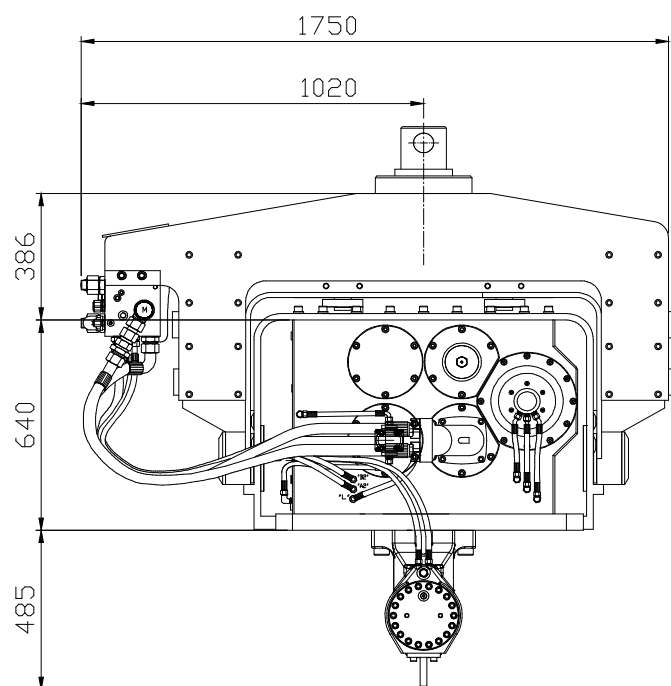

Spécifications

ICE 8RFSH

Moment excentrique	0 - 7.5 kgm	Pinces:	
Max. force centrifuge	0 - 435 kN	Pince palplanche	60TU
Max. fréquence	2300 rpm	Poids de transport par pièce	250 kg
Max. amplitude sans 60TU	14.9 mm	Pince tube	N/A
Max. amplitude avec 60TU	12 mm	Poids de transport par pièce	N/A kg
Force de traction statique	120 kN		
Pression de travail max.	350 bar	Groupe hydraulique:	
Débit d'huile max.	185 l/min	Modèle	N/A
Huile lubrifiante	oui		
Poids dynamique sans 60TU	1005 kg	Jeu de tuyau:	
Poids dynamique avec 60TU	1255 kg	Longueur	N/A m
Poids total sans 60TU & tuyaux	1930 kg	Poids de transport (±)	N/A kg

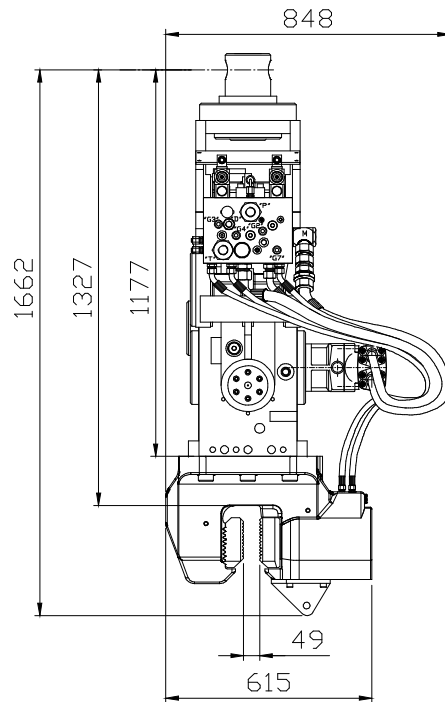
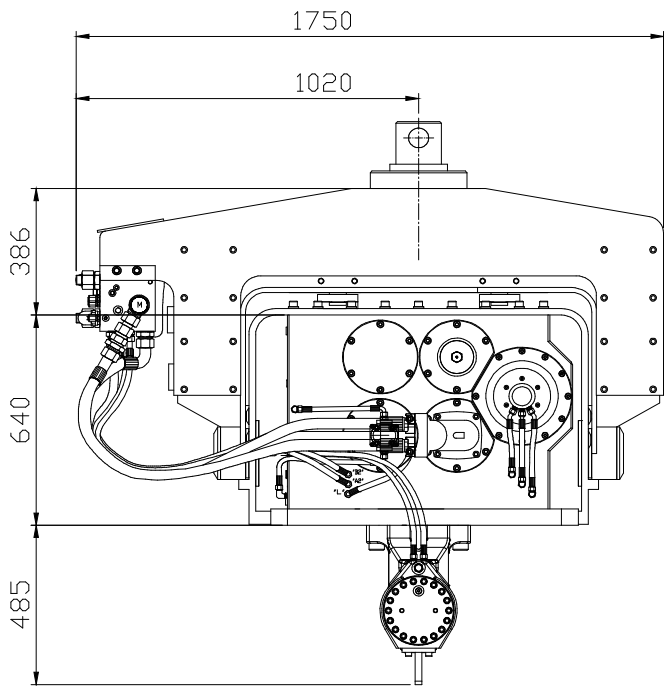

Specificaties

ICE 8RFSH

Excentrisch moment	0 - 7.5 kgm	Klemmen:	
Max. centrifugaalkracht	0 - 435 kN	Damwandklem	60TU
Max. toerental	2300 rpm	Transportgewicht per klem	250 kg
Max. amplitude excl. 60TU	14.9 mm	Pijpenklem	N/A
Max. amplitude incl. 60TU	12 mm	Transportgewicht per klem	N/A kg
Max. statische trekkracht	120 kN		
Max. werkdruk	350 bar	Aggregaat:	
Max. oliedoorstroming	185 l/min	Model	N/A
Geforceerde smering	ja		
Dynamisch gewicht excl. 60TU	1005 kg	Slangenset:	
Dynamisch gewicht incl. 60TU	1255 kg	Lengte	N/A m
Totaalgewicht excl. 60TU & slangen	1930 kg	Transportgewicht (±)	N/A kg

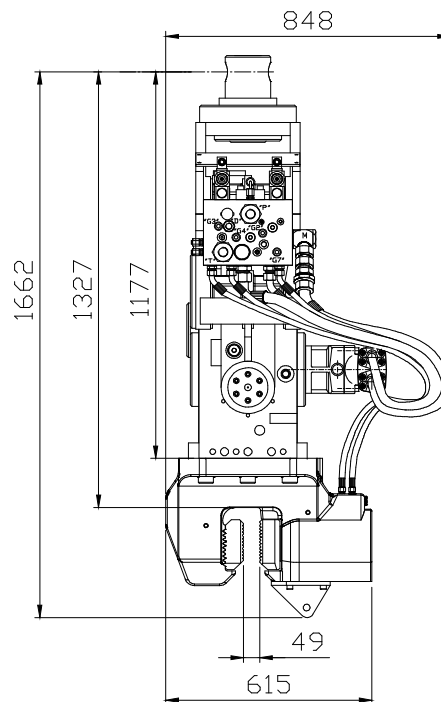
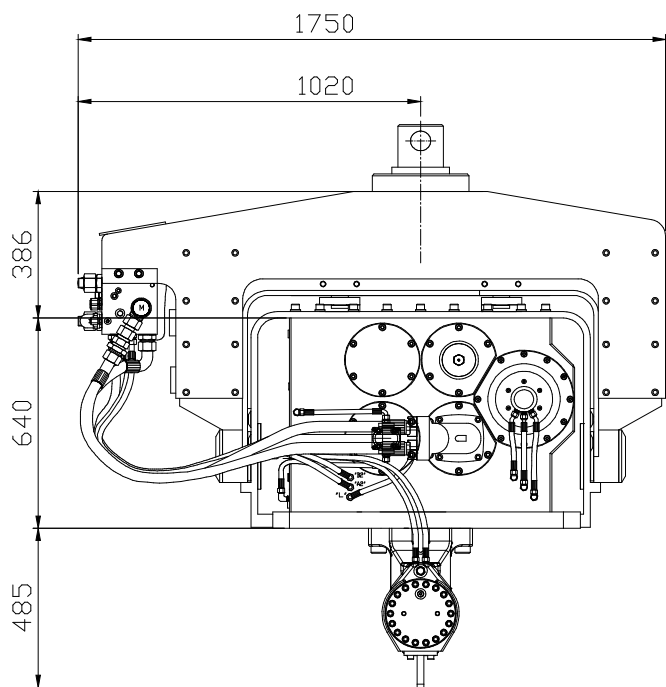

Specificatii

ICE 8RFSH

Moment excentric	0 - 7.5 kgm	Menghina:	
Forta centrifuga maxima	0 - 435 kN	Menghina pentru palplanse	60TU
Frecventa maxima	2300 rpm	Greutatea transportului pe buc.	250 kg
Amplitudinea maxima excluzand 60TU	14.9 mm	Menghina dubla	N/A
Amplitudinea maxima inclusiv 60TU	12 mm	Greutatea transportului pe buc.	N/A kg
Tractiune statica maxima	120 kN		
Presiunea maxima de lucru	350 bar	Unitate de putere:	
Debit maxim de ulei	185 l/min	Model	N/A
Ungere fortata	da		
Greutate dinamica excluzand 100TU	1005 kg	Set furtun:	
Greutate dinamica inclusiv 100TU	1255 kg	Lungime	N/A m
Greutate totala excl. 60TU & furtunuri	1930 kg	Greutatea transportului (±)	N/A kg

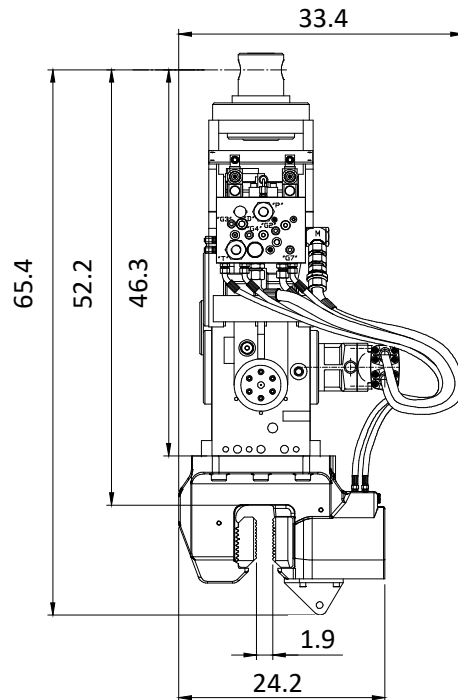
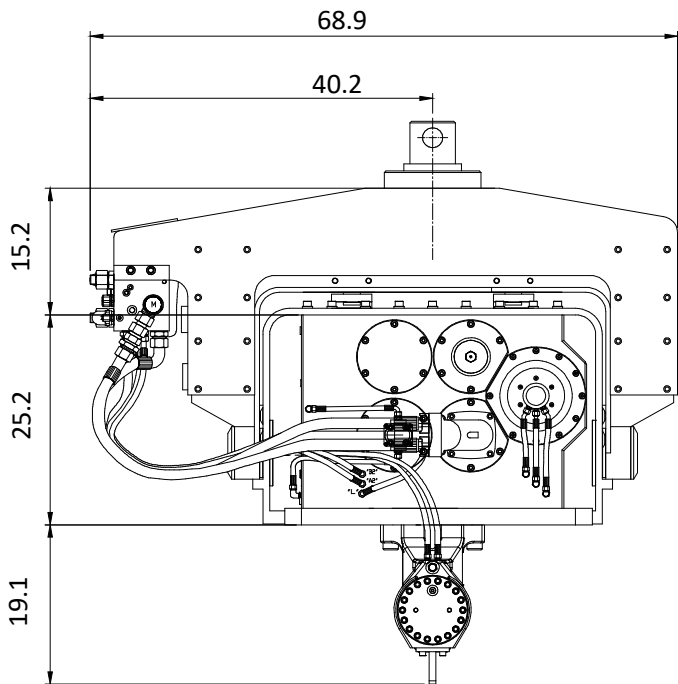

Specifications

ICE 8RFSH

Eccentric moment	0-651 lbs in	Clamps:	
Max. centrifugal force	0-48.9 US tn	Sheet pile clamp	60TU
Max. frequency	2300 rpm	Transport weight per piece	551 lbs
Max. amplitude excluding 100TU	0.59 in	Double clamps	N/A
Max. amplitude including 100TU	0.47 in	Transport weight per piece	N/A lbs
Max. static line-pull	12.2 US tn		
Max. operating pressure	5076 psi	Powerpack:	
Max. oil flow	49 gal/min	Model	N/A
Forced lubrication	yes		
Dynamic weight excluding 100TU	2216 lbs	Hose set:	
Dynamic weight including 100TU	2767 lbs	Length	N/A ft
Total weight excluding 100TU & hoses	4255 lbs	Transport weight (±)	N/A lbs