

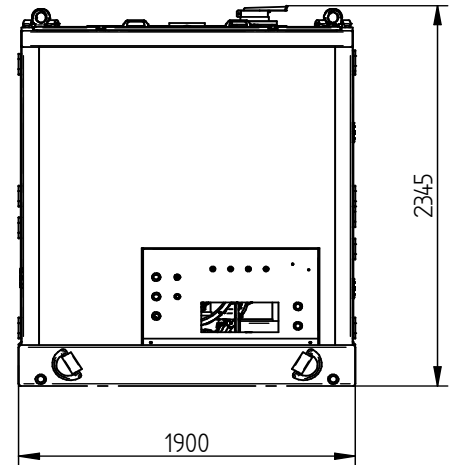

# Specification sheet

## PVE 900 STAGE - / TIER 2

Hydraulic Power Pack

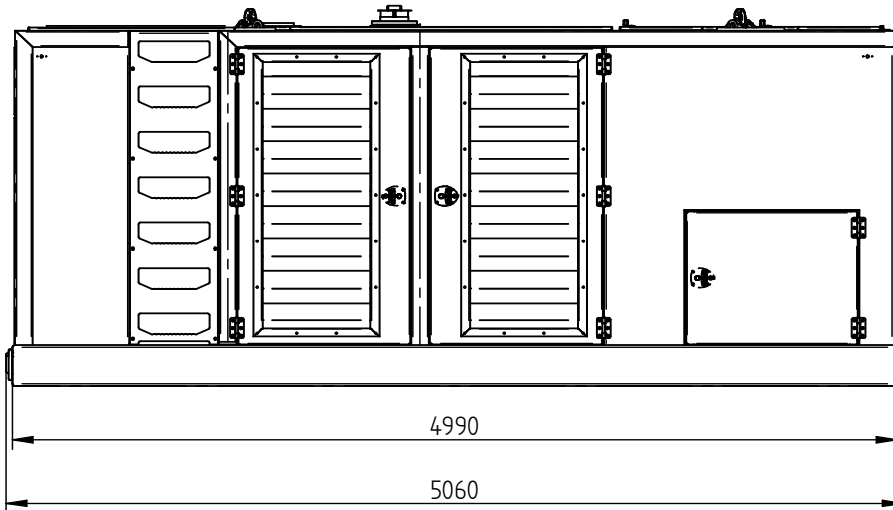
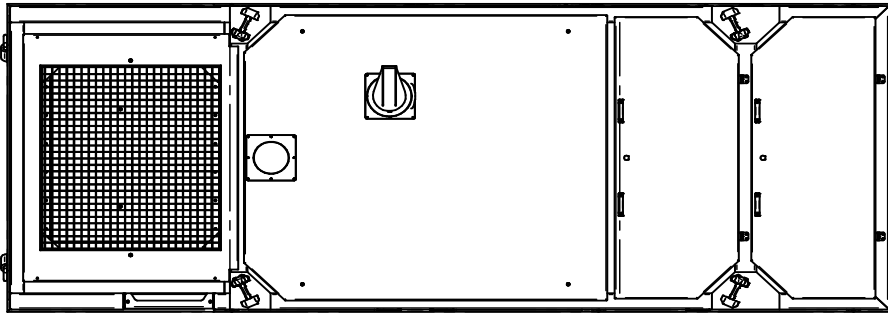

### Specifications :

### PVE 900 STAGE - / TIER 2

Diesel Engine	Volvo TAD 1643 VE-B	
Max. theoretical power	565/768	kW/HP
Max. frequency	1900	rpm
Max. operating pressure	350	bar
Hydraulic pump	Parker	
Max. oil flow	972	L/min
Diesel oil	1045	L
DEF (AdBlue) capacity	N.A.	L
Hydraulic oil	2200	L
Weight without fuel	8620	kg
Weight filled up	9500	kg

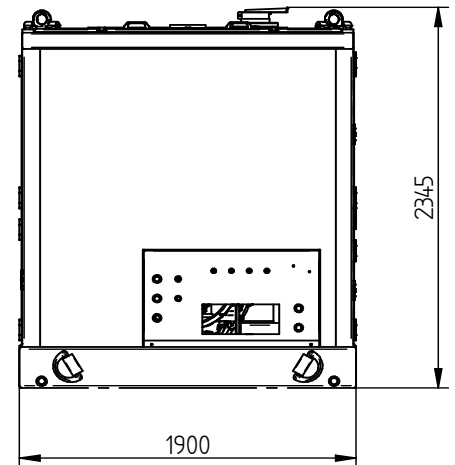
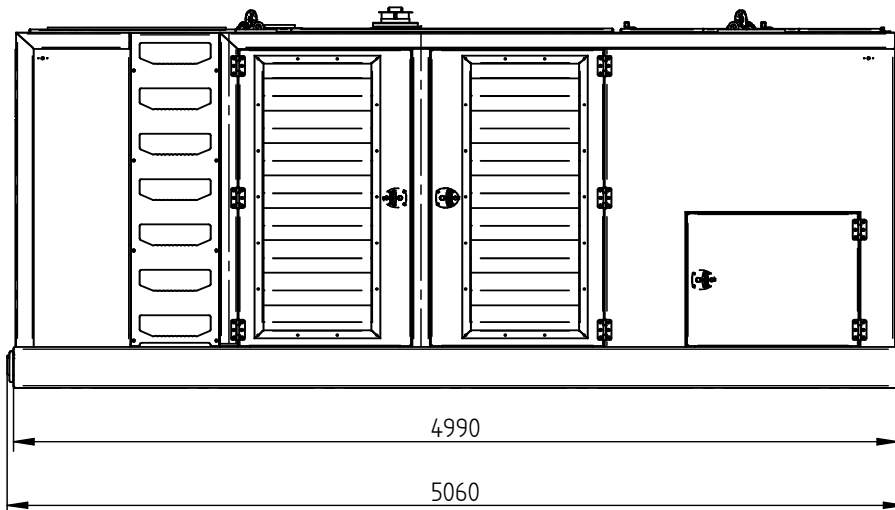
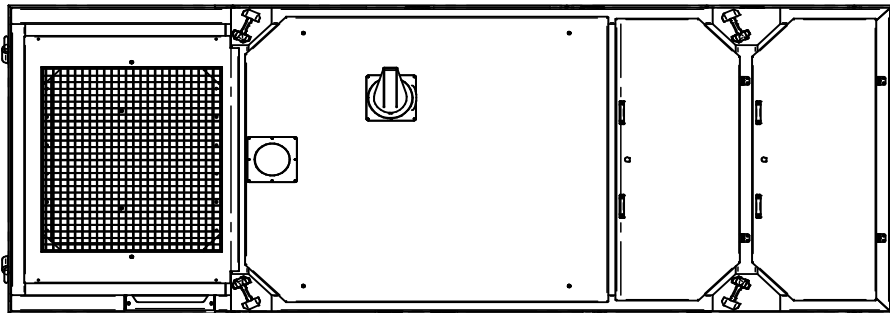

**Technische Daten :**
**PVE 900 STAGE - / TIER 2**

Dieselmotor	Volvo TAD 1643 VE-B	
Max. theoretische Leistung	565/768	kW/HP
Max. Drehzahl	1900	rpm
Max. Betriebsdruck	350	bar
Hydraulische Pumpe	Parker	
Max. Fördermenge	972	L/min
Diesel Öl	1045	L
DAF (AdBlue) kapazität	N.A.	L
Hydraulische Öl	2200	L
Gewicht ohne Diesel Öl	8620	kg
Gewicht	9500	kg

# Spécifications

## PVE 900 STAGE - / TIER 2

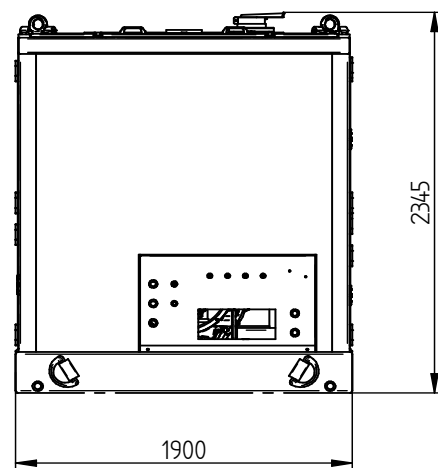
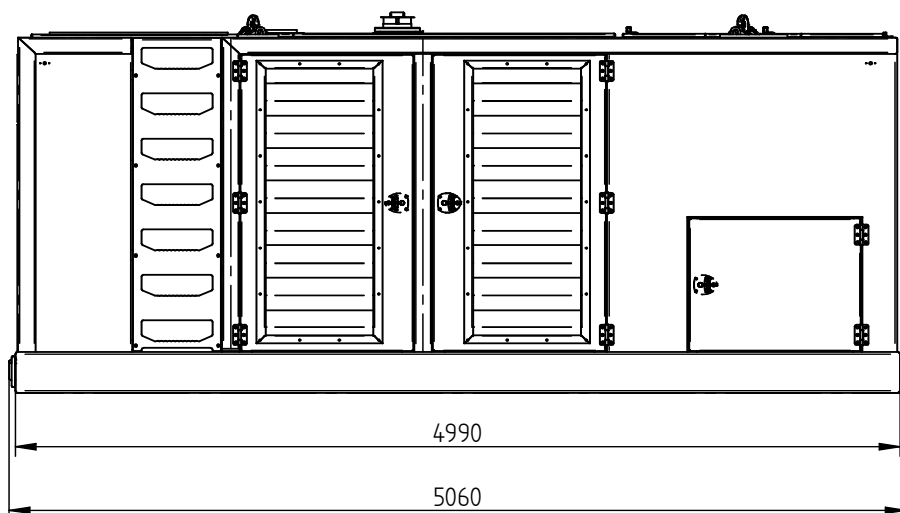
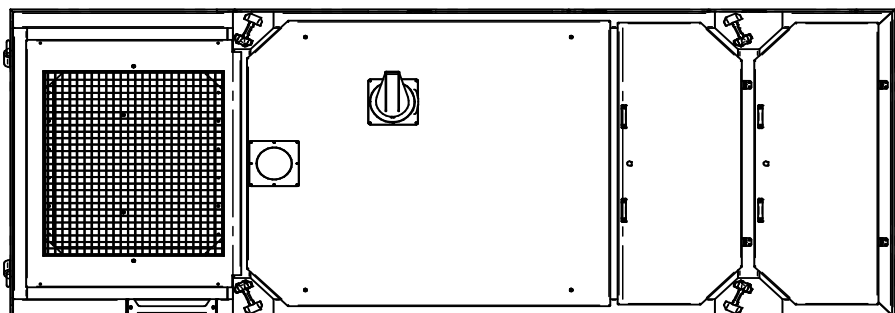
Groupe hydraulique



### Spécifications

### PVE 900 STAGE - / TIER 2

Moteur Diesel	Volvo TAD 1643 VE-B	
Puissance théorique max.	565/768	kW/HP
Max. fréquence	1900	rpm
Pression de travail max.	350	bar
Pompe hydraulique	Parker	
Débit d'huile max.	972	L/min
Huile diesel	1045	L
Capacité FED (AdBlue)	N.A.	L
Huile hydraulique	2200	L
Poids sans huile diesel	8620	kg
Poids	9500	kg



# Specificaties

## PVE 900 STAGE - / TIER 2

Hydraulisch aggregaat

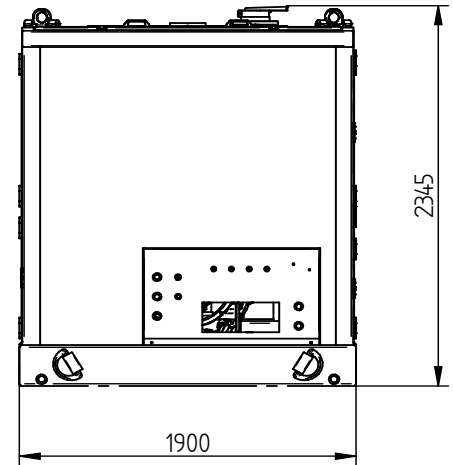
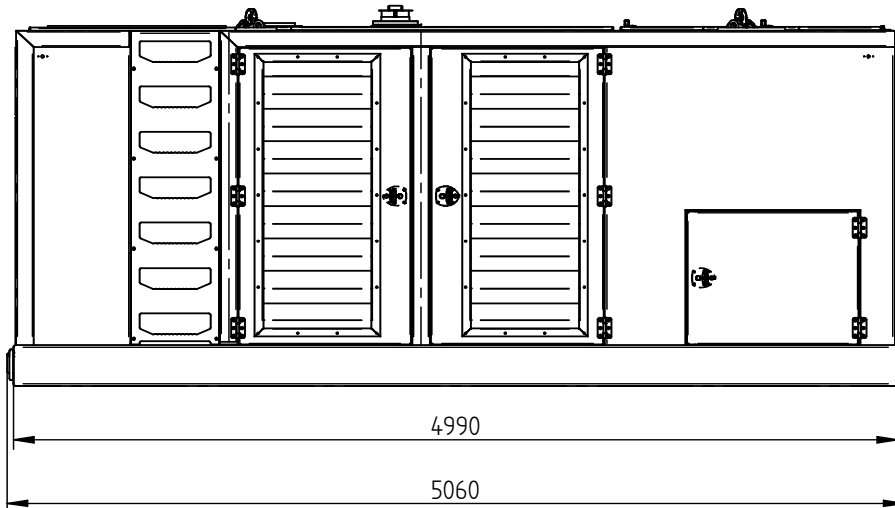
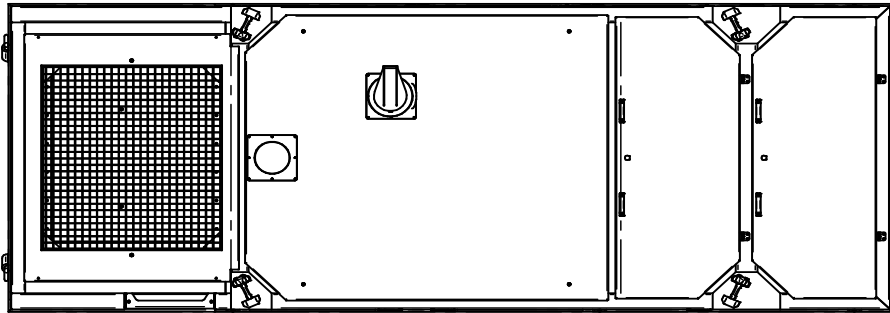

### Specificaties

### PVE 900 STAGE - / TIER 2

Dieselmotor	Volvo TAD 1643 VE-B	
Max. theoretisch vermogen	565/768	kW/HP
Max. toerental	1900	rpm
Max. werkdruk	350	bar
Hydraulische pomp	Parker	
Max. olie doorstroming	972	L/min
Diesel olie	1045	L
DEF (AdBlue) capaciteit	N.A.	L
Hydraulische olie	2200	L
Gewicht zonder diesel	8620	kg
Gewicht	9500	kg

# Specificatii

## PVE 900 STAGE - / TIER 2

Unitate de putere hidraulica

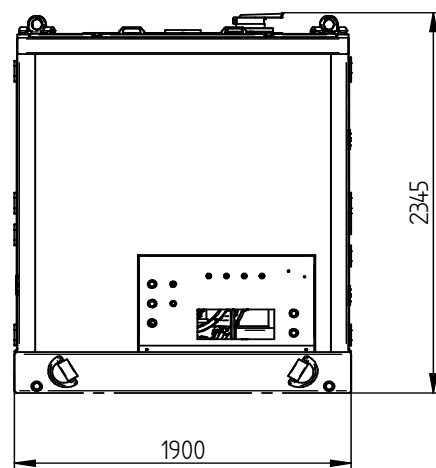
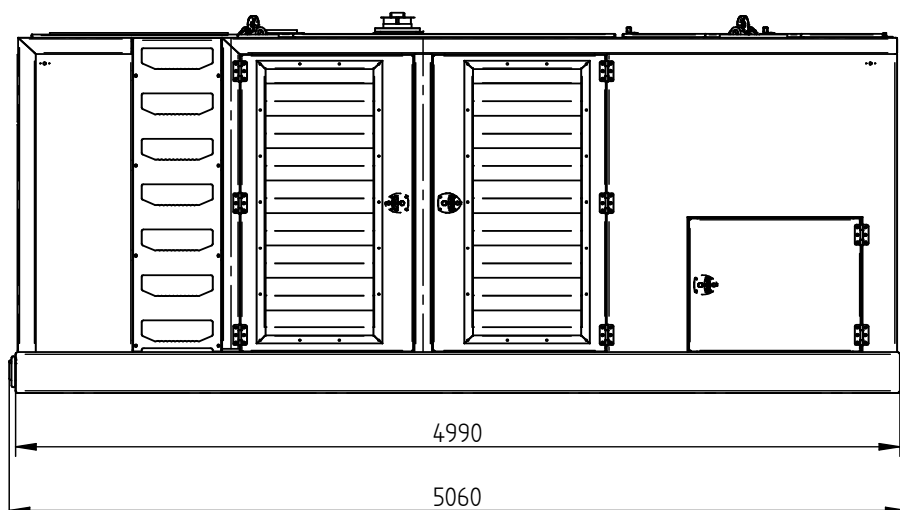
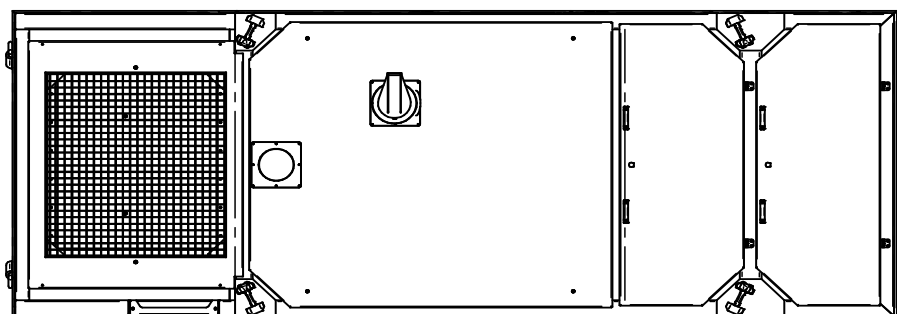

### Specificatii

### PVE 900 STAGE - / TIER 2

Motor Diesel	Volvo TAD 1643 VE-B	
Putere max. teoretica	565/768	kW/HP
Frecventa max.	1900	rpm
Presiune maxima de lucru	350	bar
Pompa hidraulica	Parker	
Debit max. de ulei	972	L/min
Ulei Diesel	1045	L
Capacitate rezervor aditiv AdBlue	N.A.	L
Ulei hidraulic	2200	L
Greutate fara ulei	8620	kg
Greutate	9500	kg

# Specifications

## PVE 900 STAGE - / TIER 2

### Hydraulic Power Pack

USA

Dimensions in inches

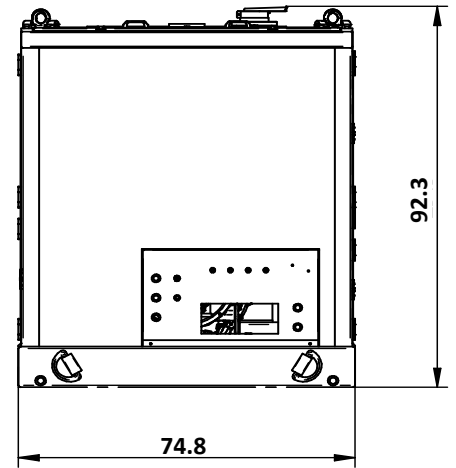
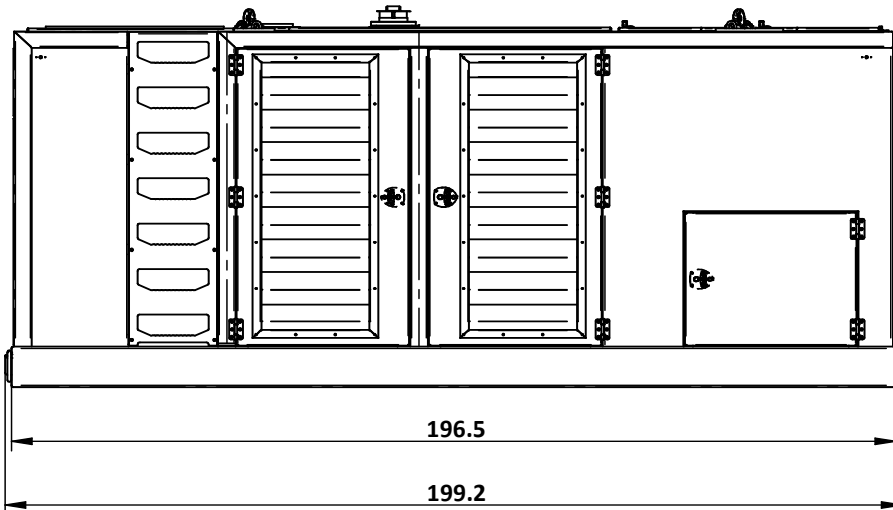
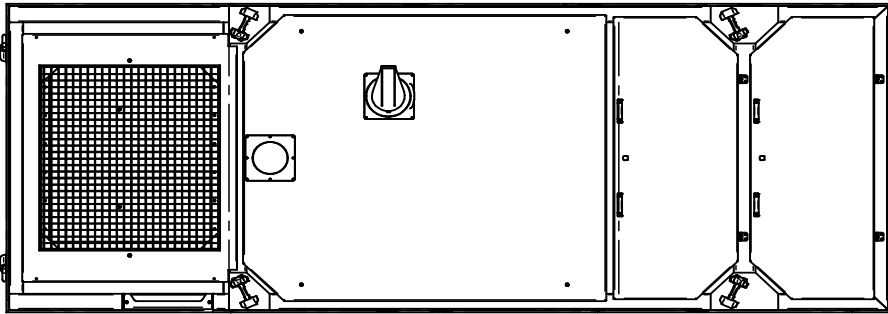
**Specifications**
**PVE 900 STAGE - / TIER 2**

Diesel Engine	Volvo TAD 1643 VE-B	
Max. theoretical power	565/768	kW/HP
Max. frequency	1,900	rpm
Max. operating pressure	5,076	psi
Hydraulic pump	Parker	
Max. oil flow	257	gal/min
Diesel Fuel	276	gal
DEF (AdBlue) capacity	N.A.	gal
Hydraulic oil	581	gal
Weight without fuel	19,004	lbs
Weight with fuel	20,944	lbs