

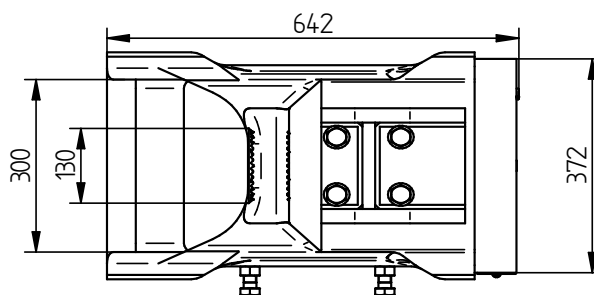

Specification sheet

PVE 100TC

Tube Clamp

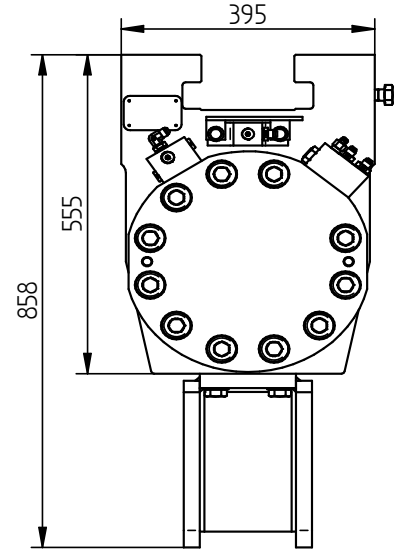
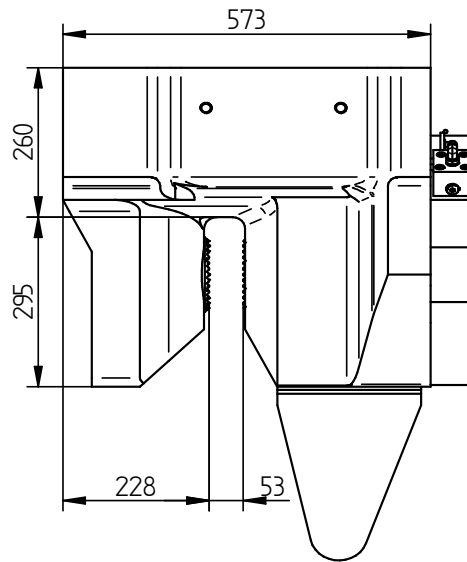
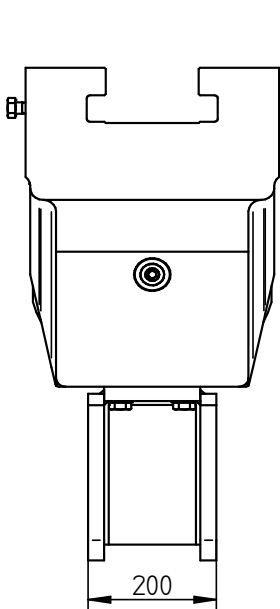
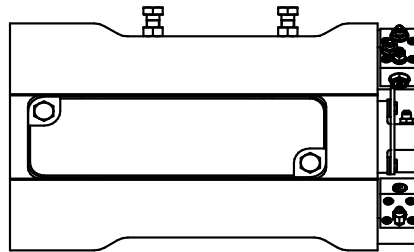
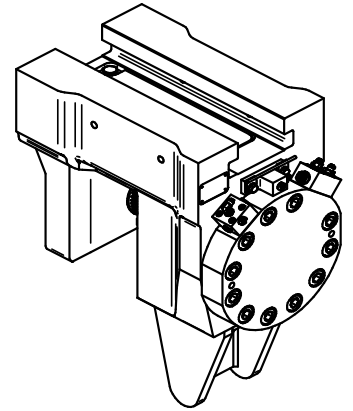

Specifications :

PVE 100TC

Tube pile clamp		
Clamping force	1000	kN
Max. operating press.	300	bar
Max. clamp open press.	180	bar
Min. Inner diameter	480	mm
Weight	690	kg



Technische Daten

PVE 100TC

Rohrzange

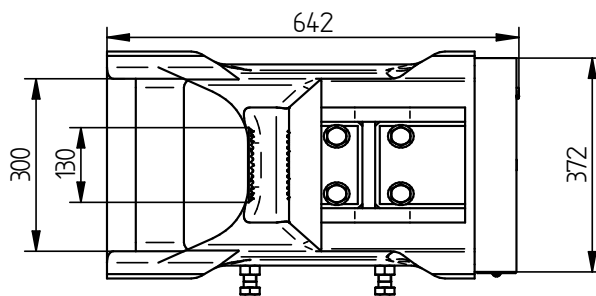
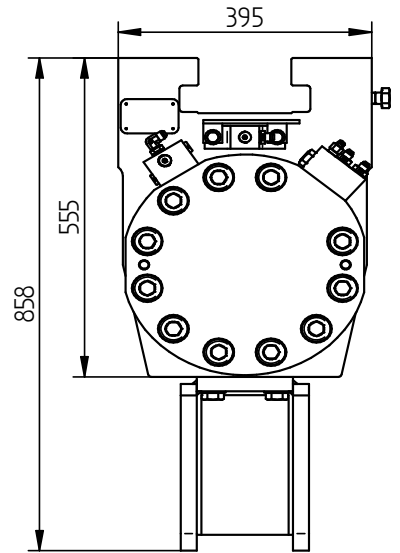
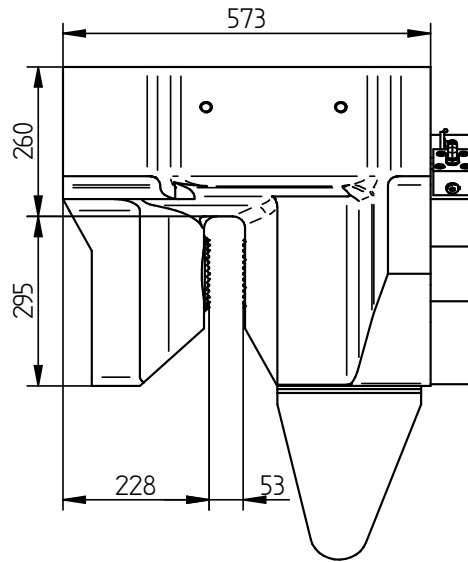
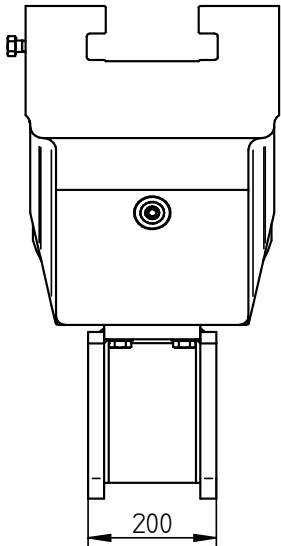
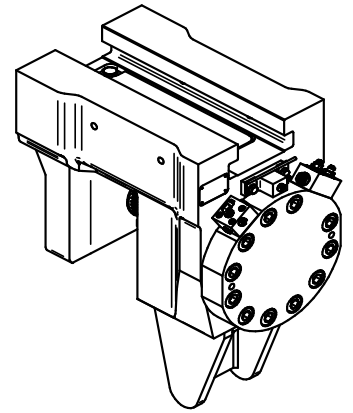
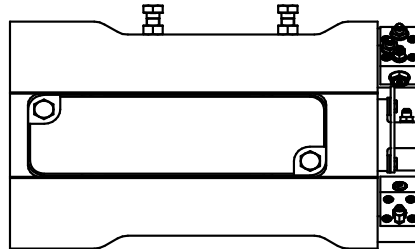

Technische Daten :

PVE 100TC

Rohrzange		
Klemmkraft	1000	kN
Max. Betriebsdruck	300	bar
Max. Druck Zange Offen	180	bar
Min. Rohr inner durchmesser	480	mm
Gewicht	690	kg



Spécifications

PVE 100TC

Pince tube

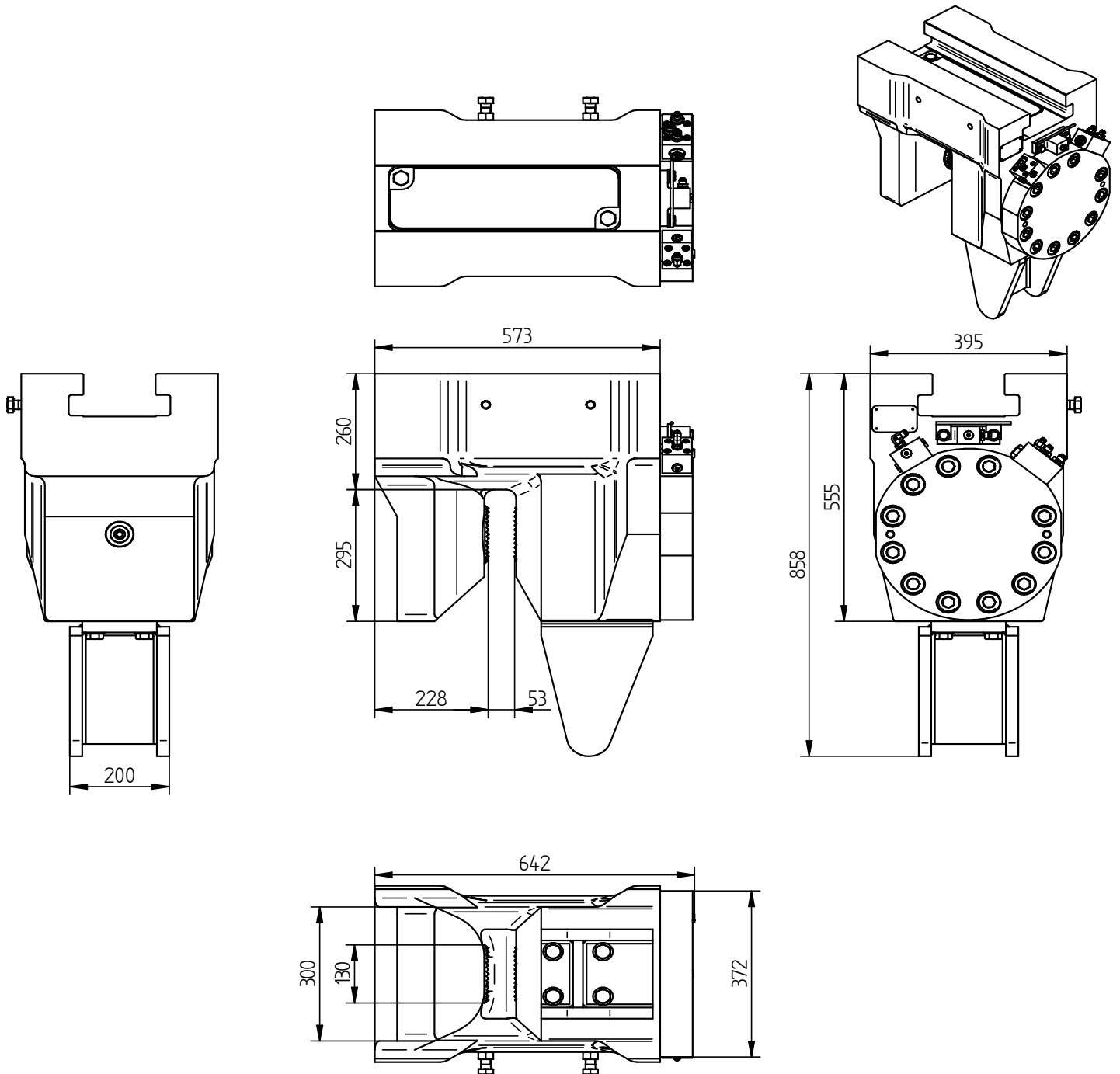

Spécifications

PVE 100TC

Pince tube		
Force de serrage	1000	kN
Pression de travail max.	300	bar
Pression pince ouvert max.	180	bar
Diamètre tube dedans min.	480	mm
Poids	690	kg



Specificaties

PVE 100TC

Damwandklem

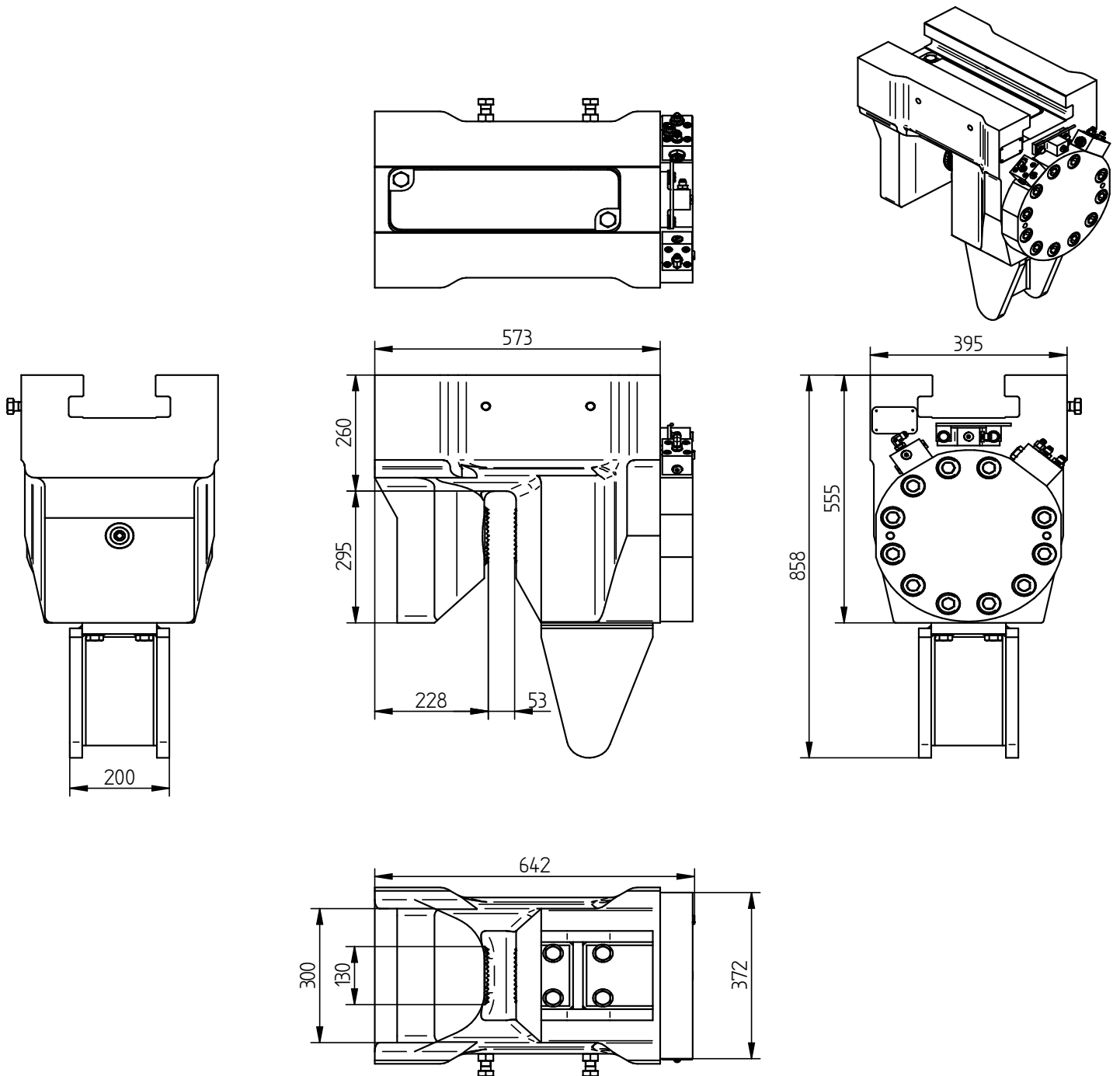

Specificaties		PVE 100TC	
Damwandklem			
Klemkracht		1000	kN
Max. werkdruk		300	bar
Max. klem open druk		180	bar
Min. buis binnen diameter		480	mm
Gewicht		690	kg



Specificatii PVE 100TC

Menghina pentru tuburi

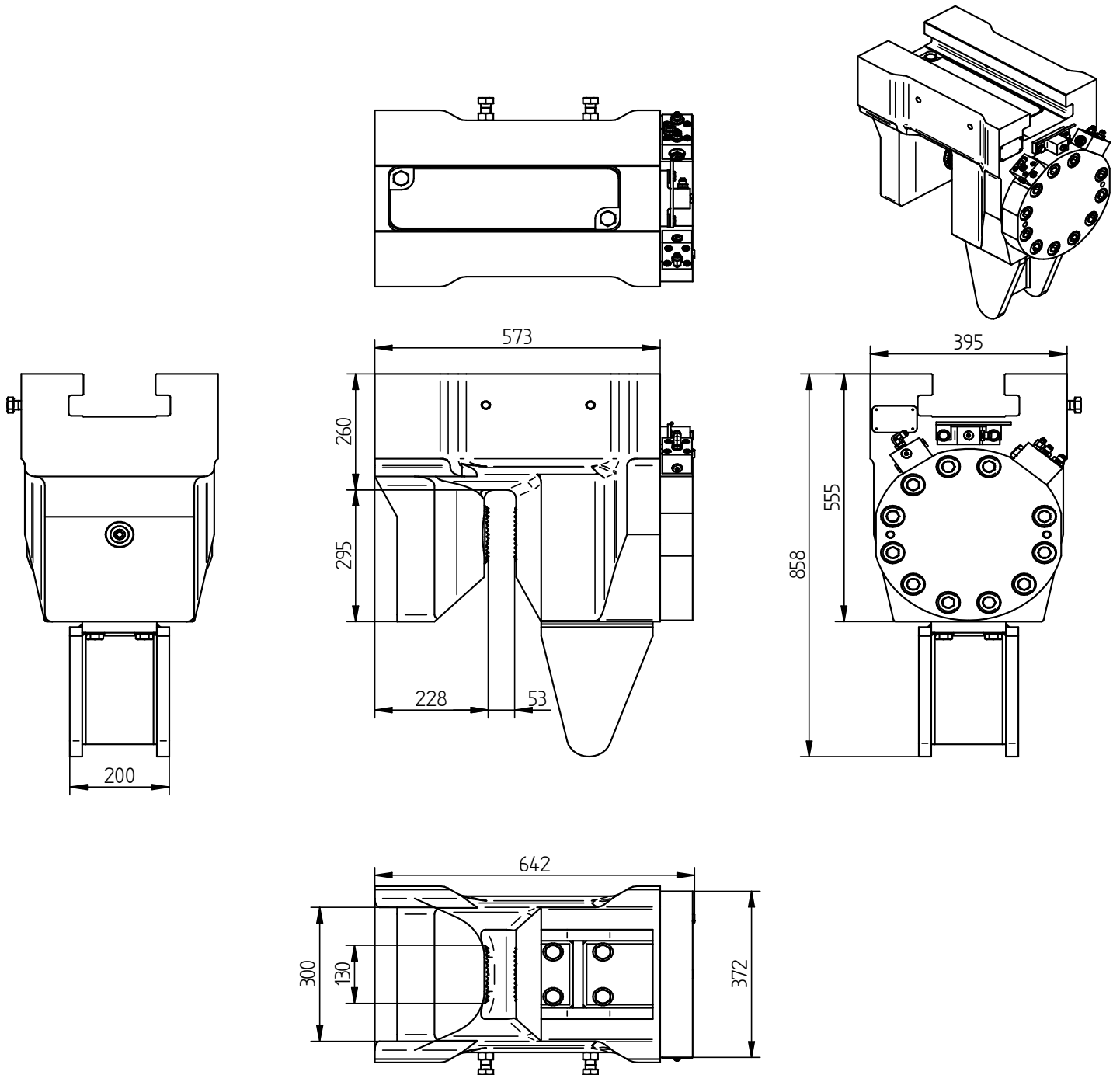

Specificatii	PVE 100TC	
Menghina pentru tuburi		
Putere de strangere	1000	kN
Presiunea maxima de lucru	300	bar
Presiunea maxima cu menghina deschisa	180	bar
Diametrul interior minim	480	mm
Greutate	690	kg



Specifications

PVE 100TC

Tube pile clamp

USA

INCHES

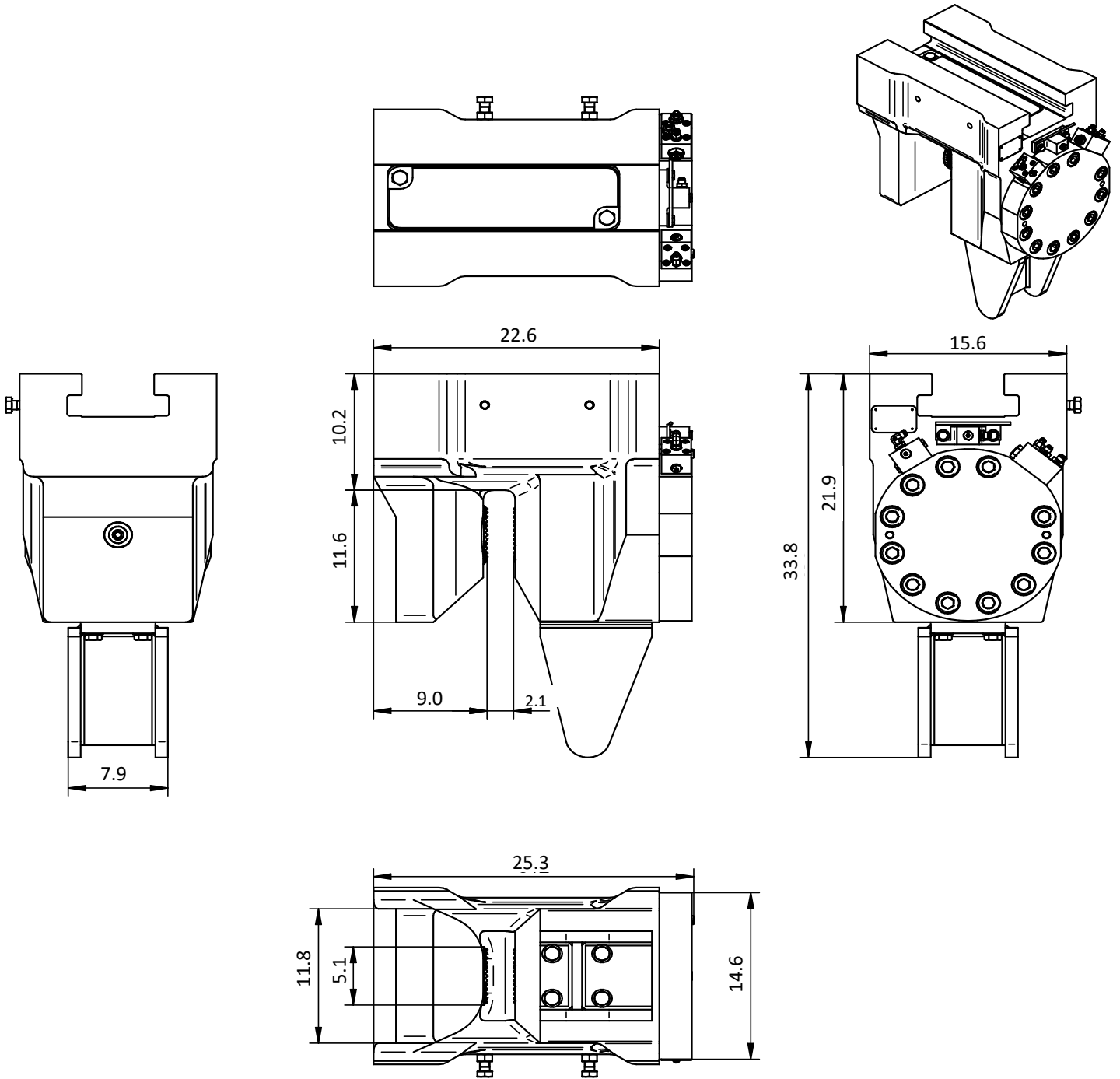

Specifications

PVE 100TC

Tube pile clamp		
Clamping force	112	ton
Max. operating press.	4,351	psi
Max. clamp open press.	2,611	psi
Min. Inner diameter	19	inch
Weight	1,521	lbs