

Specifications :

PVE 200 STAGE V

Diesel Engine	Volvo TAD 582 VE	
Max. theoretical power	160/218	kW/HP
Max. frequency	2300	rpm
Max. operating pressure	350	bar
Hydraulic pump	Parker	
Max. oil flow	211	L/min
Diesel oil	490	L
DEF (AdBlue) capacity	25	L
Hydraulic oil	540	L
Weight without fuel	3900	kg
Weight filled up	4350	kg



Technische Daten PVE 200 STAGE V

Aggregat

Deutsch

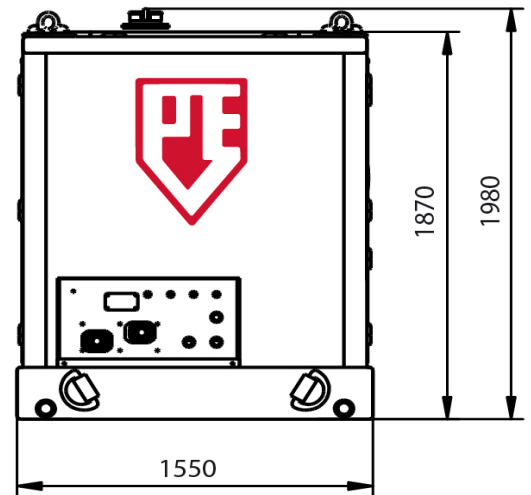
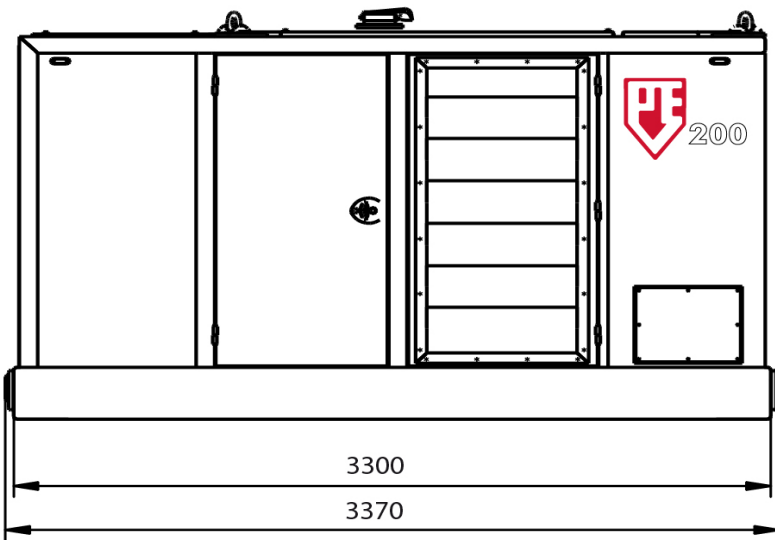
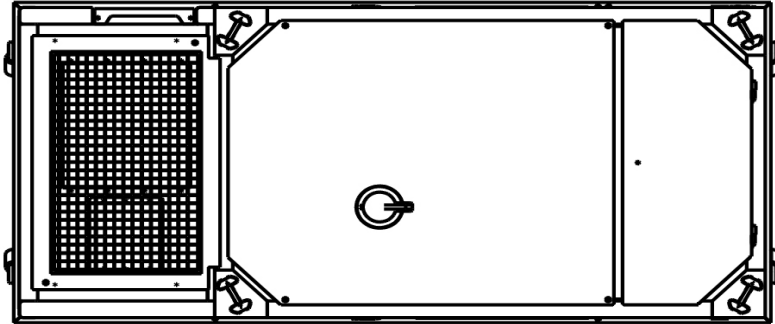

Technische Daten :

PVE 200 STAGE V

Dieselmotor	Volvo TAD 582 VE	
Max. theoretische Leistung	160/218	kW/HP
Max. Drehzahl	2300	rpm
Max. Betriebsdruck	350	bar
Hydraulische Pumpe	Parker	
Max. Fördermenge	211	L/min
Diesel Öl	490	L
DAF (AdBlue) kapazität	25	L
Hydraulische Öl	540	L
Gewicht ohne Diesel Öl	3900	kg
Gewicht	4350	kg



Spécifications

PVE 200 STAGE V

Groupe hydraulique

Français

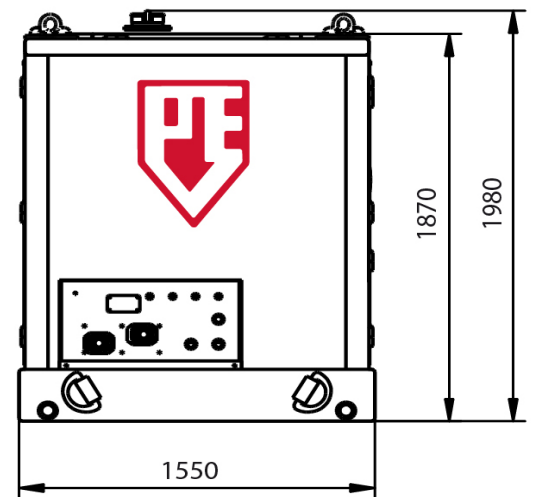
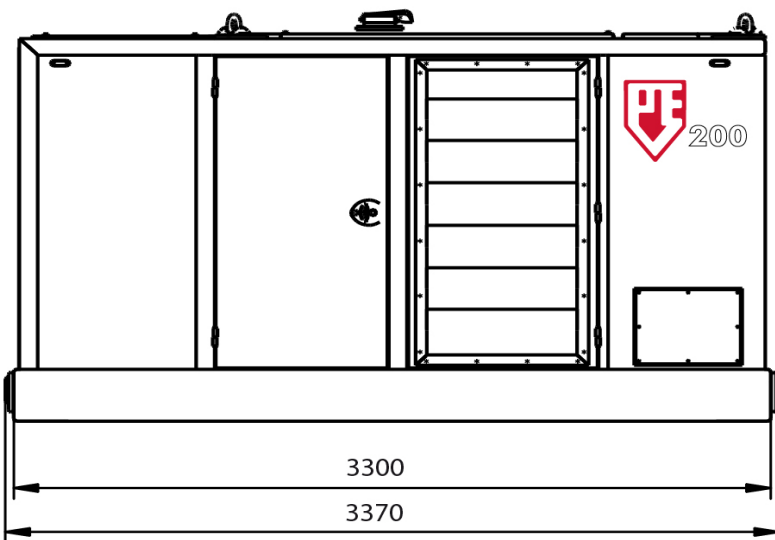
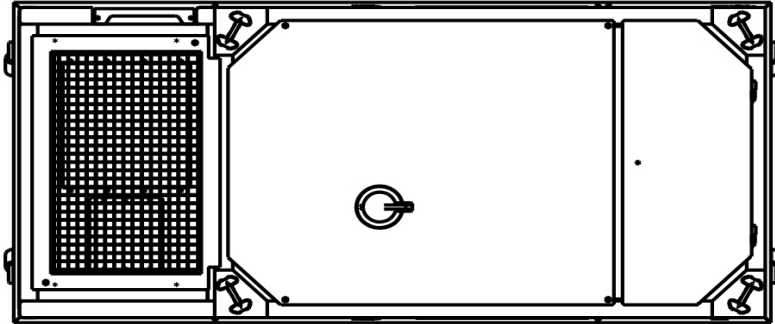

Spécifications

PVE 200 STAGE V

Moteur Diesel	Volvo TAD 582 VE	
Puissance théorique max.	160/218	kW/HP
Max. fréquence	2300	rpm
Pression de travail max.	350	bar
Pompe hydraulique	Parker	
Débit d'huile max.	211	L/min
Huile diesel	490	L
Capacité FED (AdBlue)	25	L
Huile hydraulique	540	L
Poids sans huile diesel	3900	kg
Poids	4350	kg



Specificaties PVE 200 STAGE V

Hydraulisch aggregaat

Nederlands

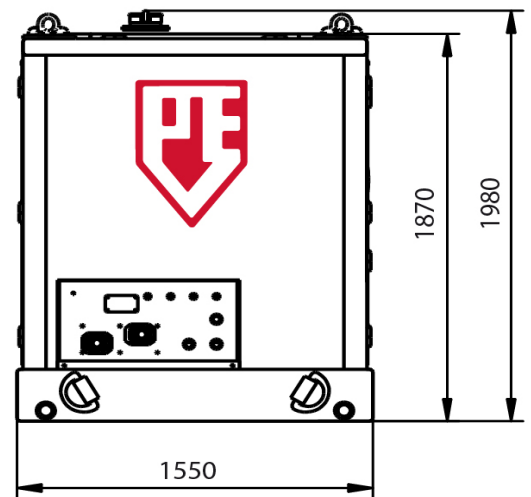
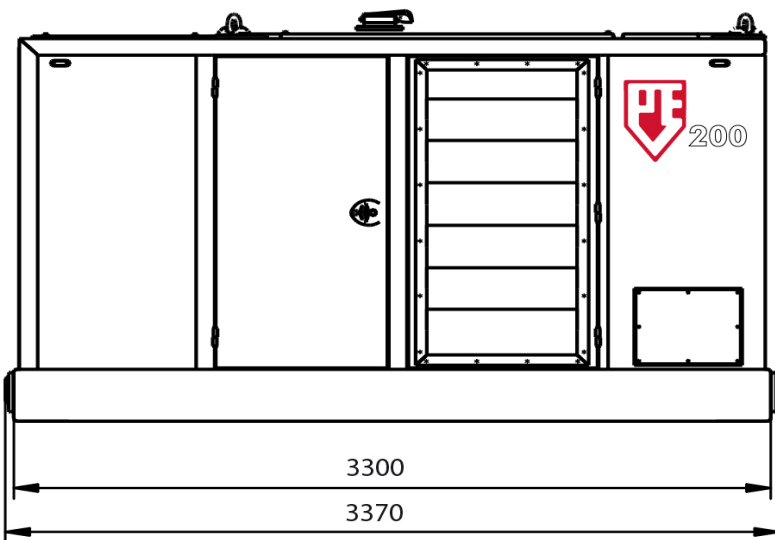
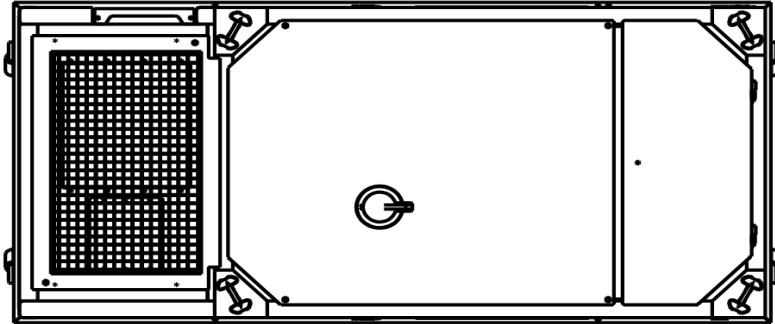

Specificaties

PVE 200 STAGE V

Dieselmotor	Volvo TAD 582 VE	
Max. theoretisch vermogen	160/218	kW/HP
Max. toerental	2300	rpm
Max. werkdruk	350	bar
Hydraulische pomp	Parker	
Max. olie doorstroming	211	L/min
Diesel olie	490	L
DEF (AdBlue) capaciteit	25	L
Hydraulische olie	540	L
Gewicht zonder diesel	3900	kg
Gewicht	4350	kg

Specificatii

PVE 200 STAGE V

Unitate de putere hidraulica

Español

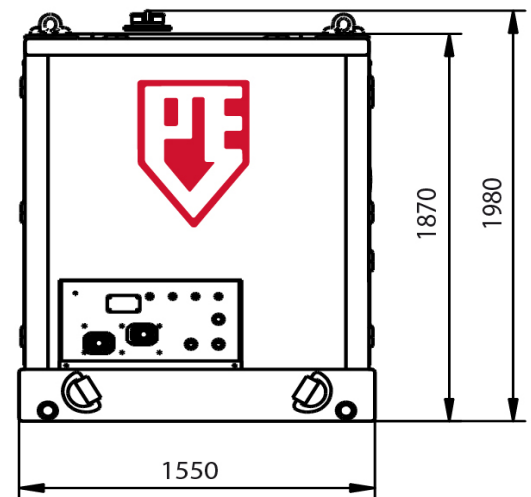
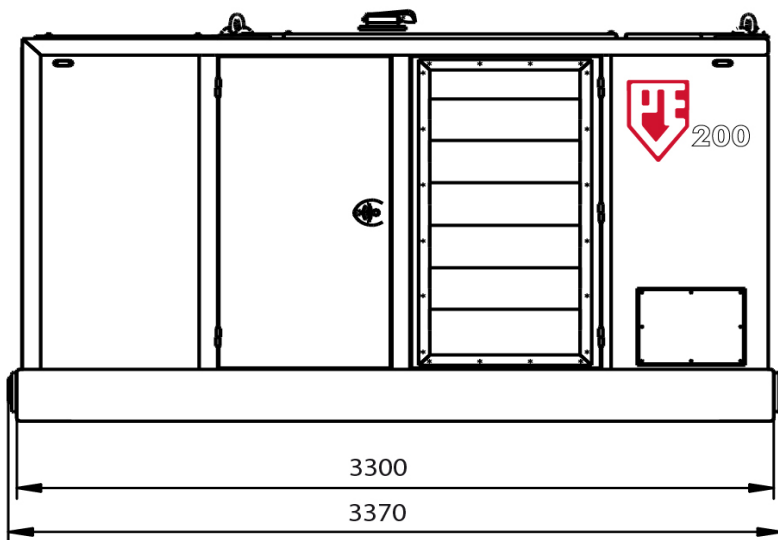
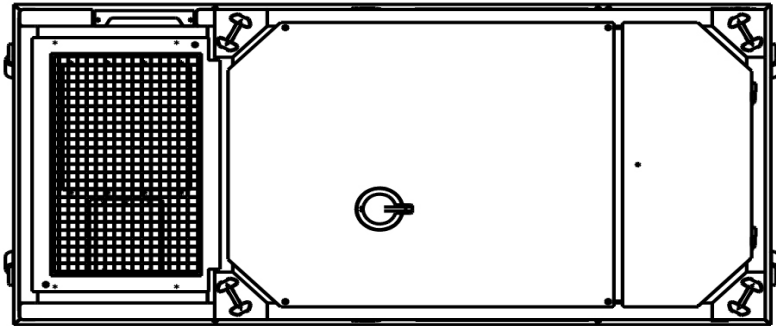

Specificatii

PVE 200 STAGE V

Motor Diesel	Volvo TAD 582 VE	
Putere max. teoretica	160/218	kW/HP
Frecventa max.	2300	rpm
Presiune maxima de lucru	350	bar
Pompa hidraulica	Parker	
Debit max. de ulei	211	L/min
Ulei Diesel	490	L
Capacitate rezervor aditiv AdBlue	25	L
Ulei hidraulic	540	L
Greutate fara ulei	3900	kg
Greutate	4350	kg

Specifications

PVE 200 STAGE V

Hydraulic Power Pack

USA

Dimensions in inches

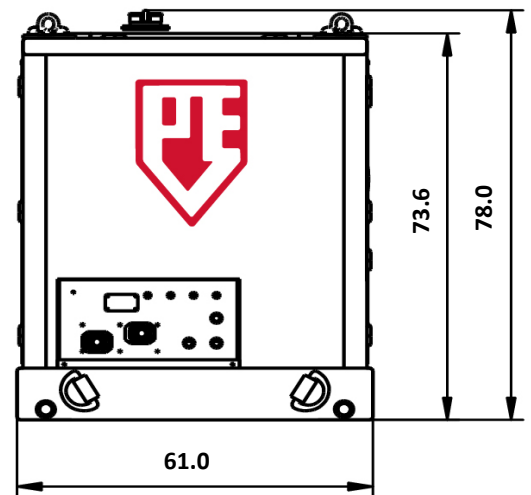
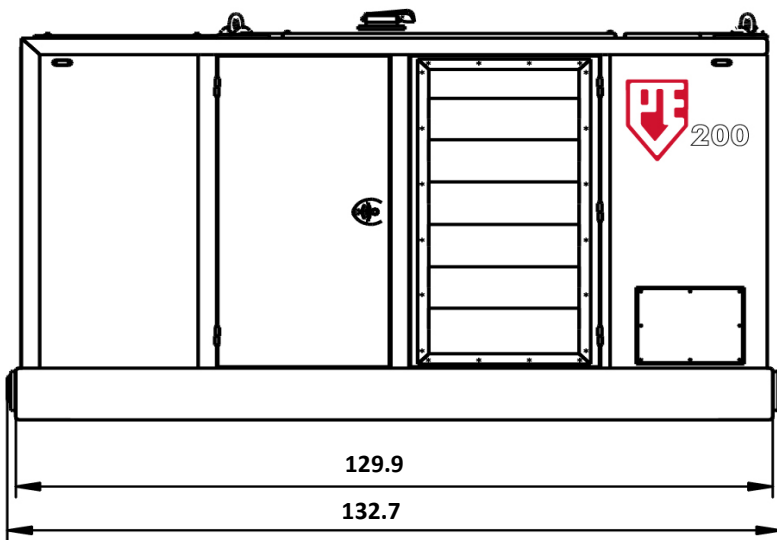
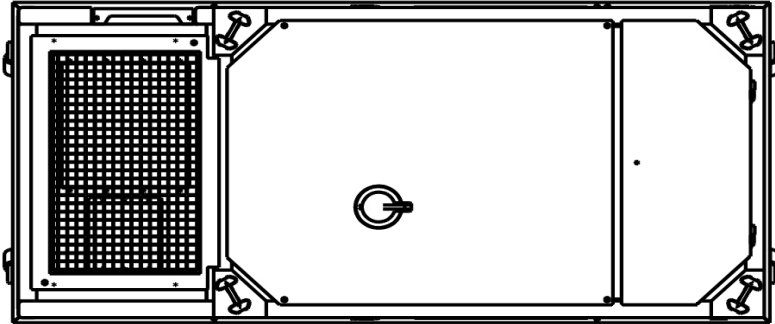

Specifications

PVE 200 STAGE V

Diesel Engine	Volvo TAD 582 VE	
Max. theoretical power	160/218	kW/HP
Max. frequency	2,300	rpm
Max. operating pressure	5,076	psi
Hydraulic pump	Parker	
Max. oil flow	56	gal/min
Diesel Fuel	129	gal
DEF (AdBlue) capacity	7	gal
Hydraulic oil	143	gal
Weight without fuel	8,598	lbs
Weight with fuel	9,590	lbs