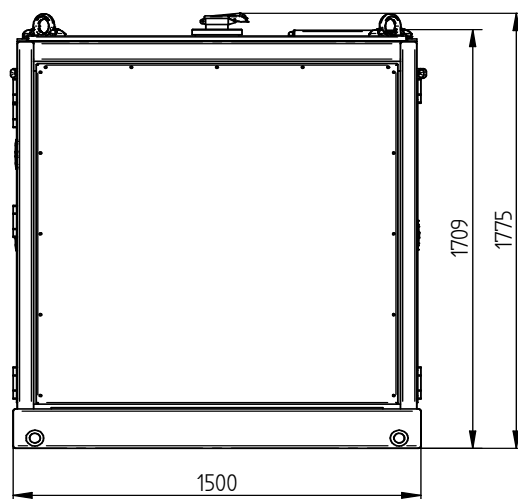
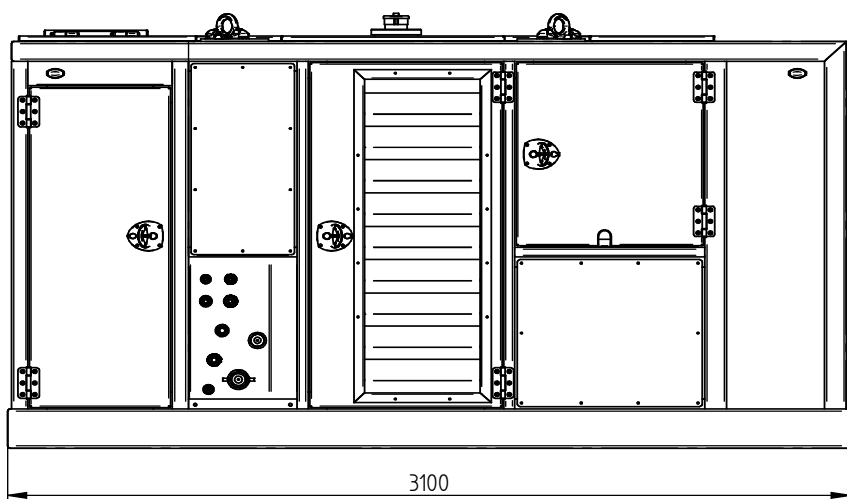
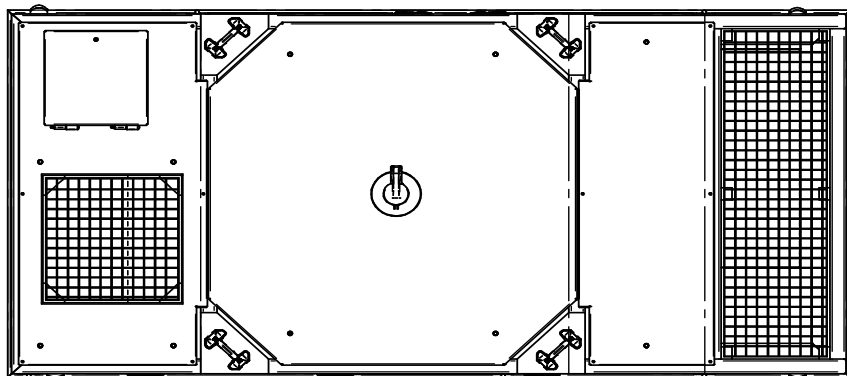

Specification sheet

PVE 200 XS STAGE V / TIER 4F

Hydraulic Power Pack

Specifications :
PVE 200 XS STAGE V / TIER 4F

Diesel Engine	Caterpillar C7.1	
Max. theoretical power	186/249	kW/HP
Max. frequency	2000	rpm
Max. operating pressure	350	bar
Hydraulic pump	Parker	
Max. oil flow	280	L/min
Diesel oil	370	L
DEF (AdBlue) capacity	33	L
Hydraulic oil	500	L
Weight without fuel	3560	kg
Weight filled up	3900	kg

Technische Daten

PVE 200 XS STAGE V / TIER 4F

Aggregat

Deutsch

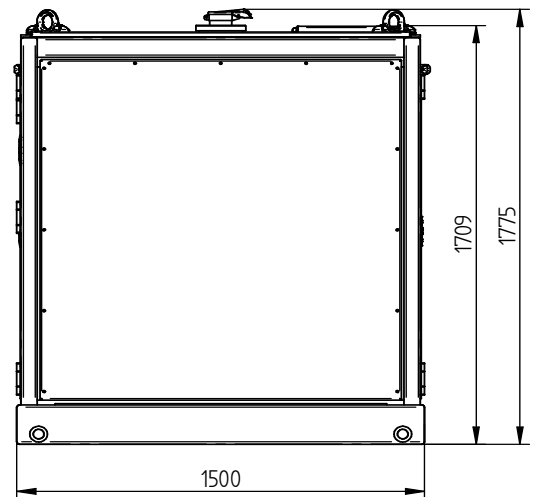
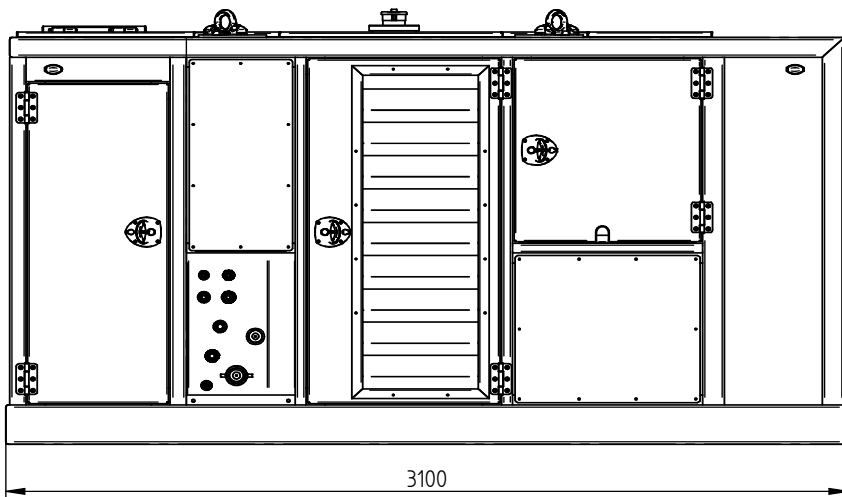
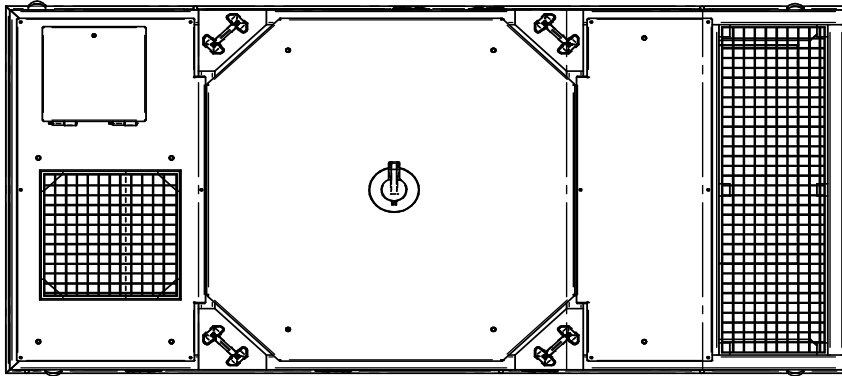
Technische Daten :
PVE 200 XS STAGE V / TIER 4F

Dieselmotor	Caterpillar C7.1	
Max. theoretische Leistung	186/249	kW/HP
Max. Drehzahl	2000	rpm
Max. Betriebsdruck	350	bar
Hydraulische Pumpe	Parker	
Max. Fördermenge	280	L/min
Diesel Öl	370	L
DAF (AdBlue) kapazität	33	L
Hydraulische Öl	500	L
Gewicht ohne Diesel Öl	3560	kg
Gewicht	3900	kg



Spécifications

PVE 200 XS STAGE V / TIER 4F

Groupe hydraulique

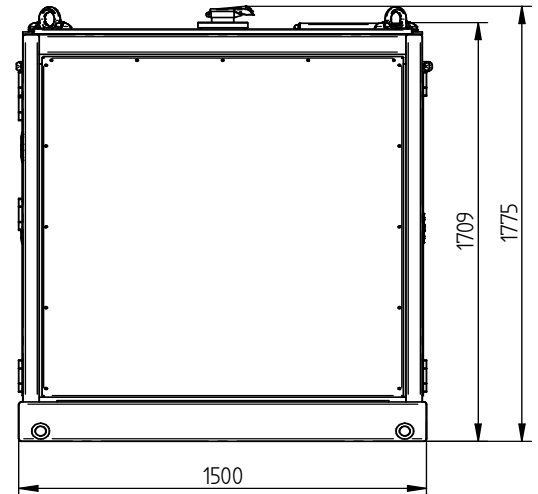
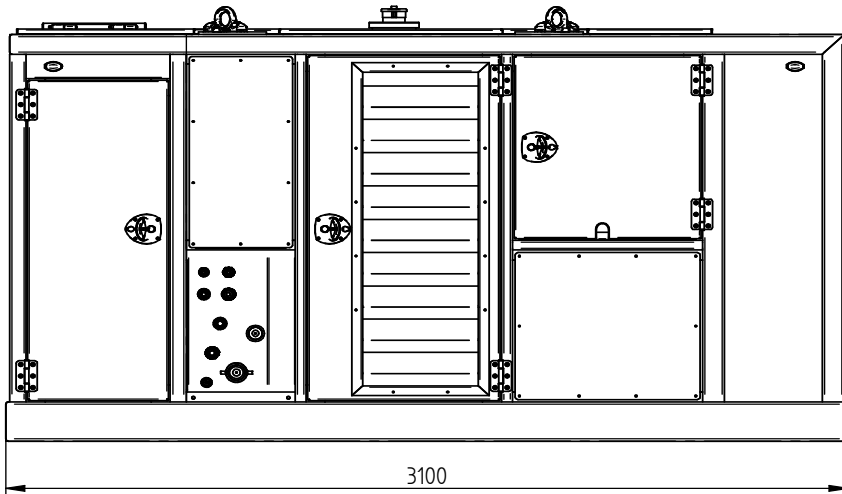
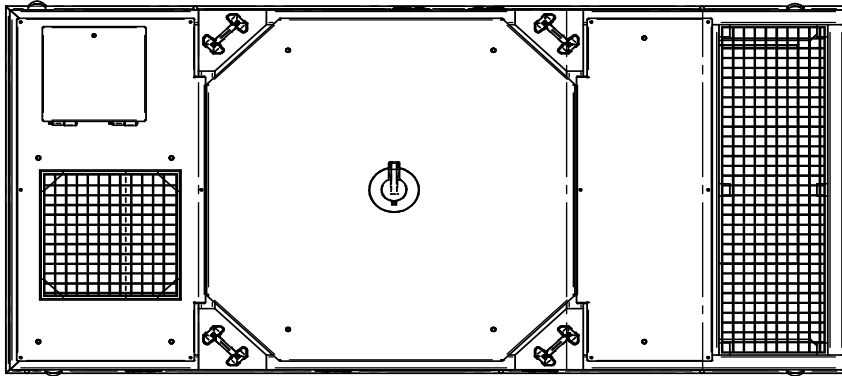
**Spécifications****PVE 200 XS STAGE V / TIER 4F**

Moteur Diesel	Caterpillar C7.1	
Puissance théorique max.	186/249	kW/HP
Max. fréquence	2000	rpm
Pression de travail max.	350	bar
Pompe hydraulique	Parker	
Débit d'huile max.	280	L/min
Huile diesel	370	L
Capacité FED (AdBlue)	33	L
Huile hydraulique	500	L
Poids sans huile diesel	3560	kg
Poids	3900	kg

Specificaties

PVE 200 XS STAGE V / TIER 4F

Hydraulisch aggregaat

Nederlands

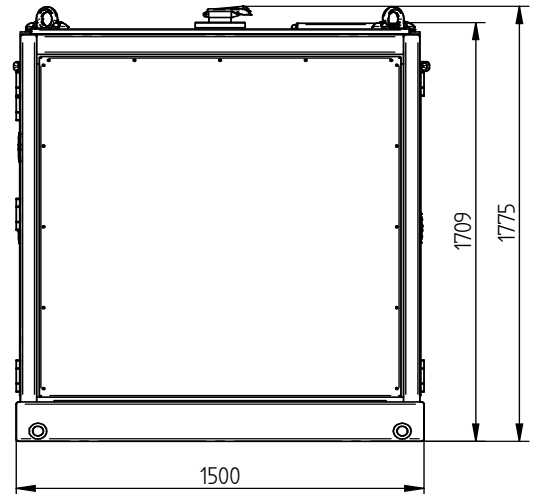
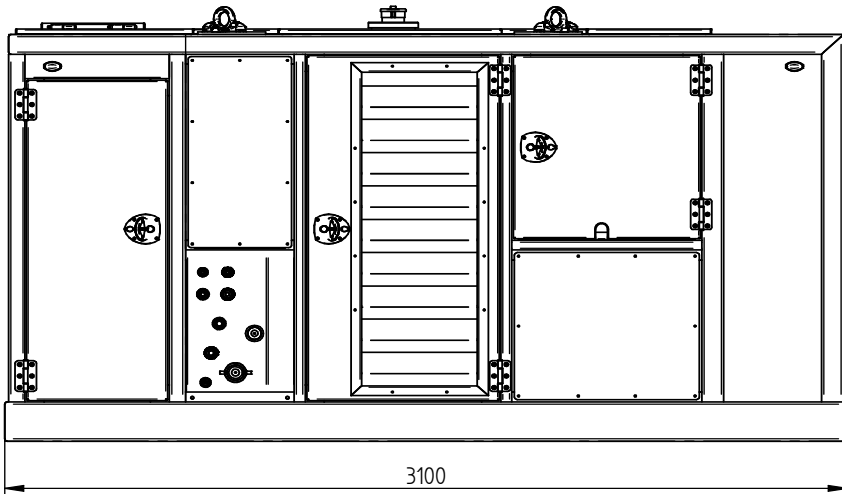
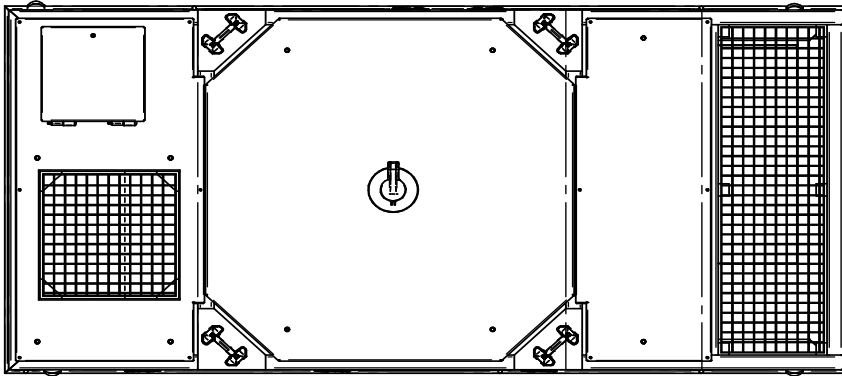

Specificaties

PVE 200 XS STAGE V / TIER 4F

Dieselmotor	Caterpillar C7.1	
Max. theoretisch vermogen	186/249	kW/HP
Max. toerental	2000	rpm
Max. werkdruk	350	bar
Hydraulische pomp	Parker	
Max. olie doorstroming	280	L/min
Diesel olie	370	L
DEF (AdBlue) capaciteit	33	L
Hydraulische olie	500	L
Gewicht zonder diesel	3560	kg
Gewicht	3900	kg

Specificatii

PVE 200 XS STAGE V / TIER 4F

Unitate de putere hidraulica

Español

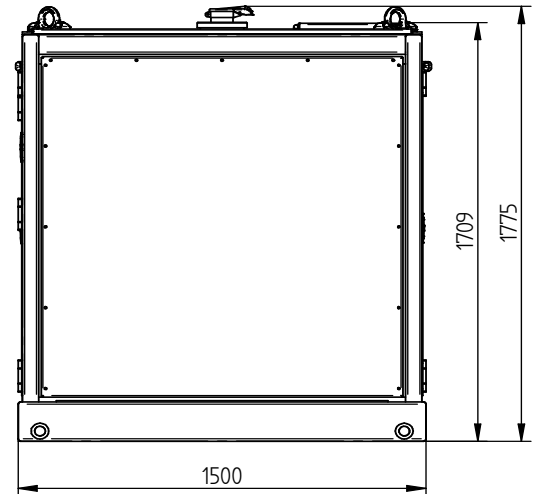
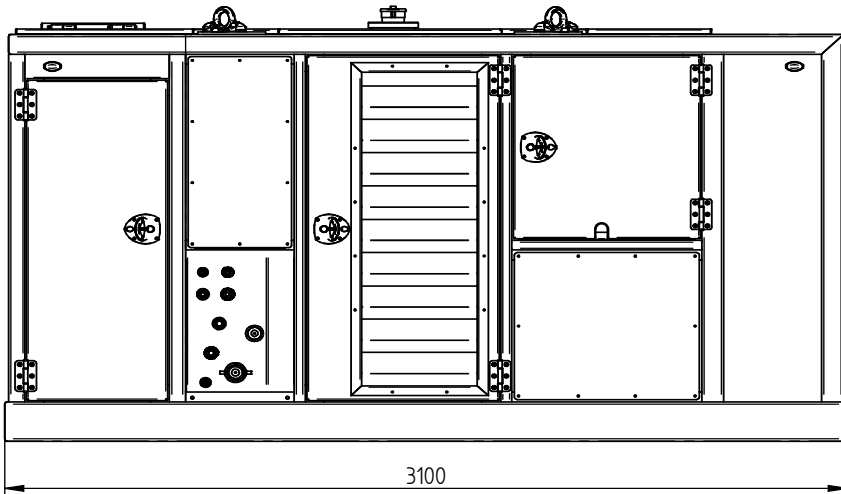
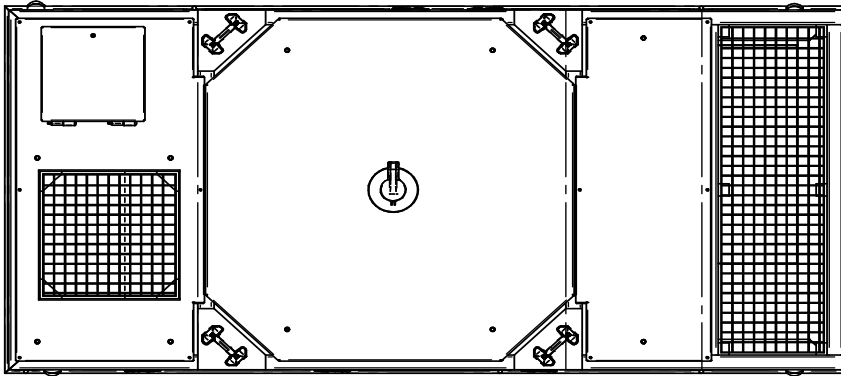
Specificatii
PVE 200 XS STAGE V / TIER 4F

Motor Diesel	Caterpillar C7.1	
Putere max. teoretica	186/249	kW/HP
Frecventa max.	2000	rpm
Presiune maxima de lucru	350	bar
Pompa hidraulica	Parker	
Debit max. de ulei	280	L/min
Ulei Diesel	370	L
Capacitate rezervor aditiv AdBlue	33	L
Ulei hidraulic	500	L
Greutate fara ulei	3560	kg
Greutate	3900	kg

Specifications

PVE 200 XS STAGE V / TIER 4F

Hydraulic Power Pack

USA

Dimensions in inches

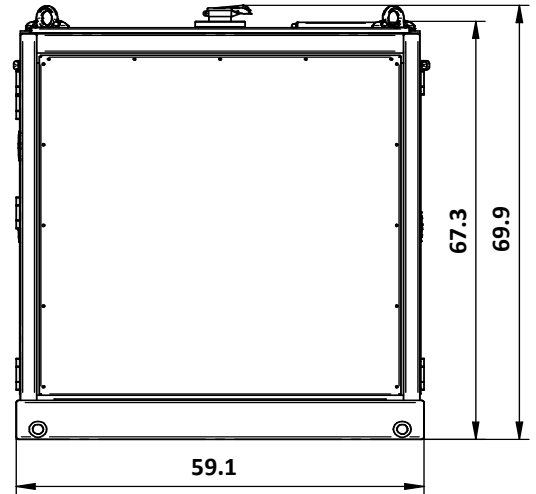
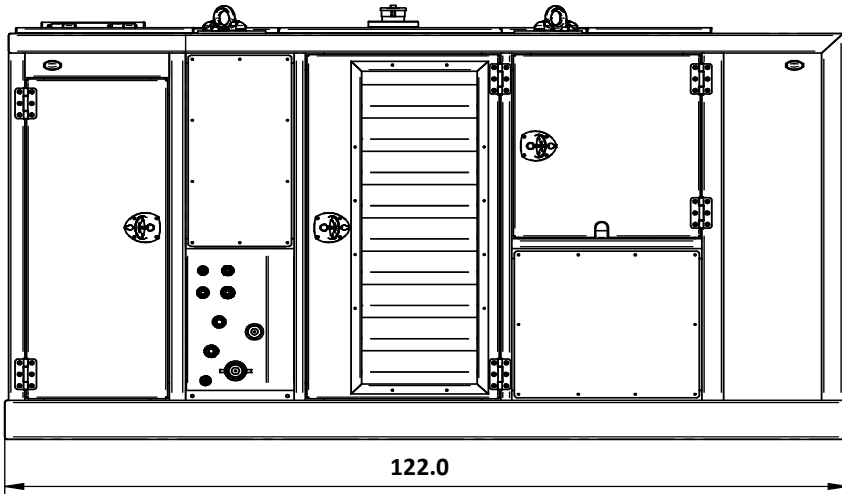
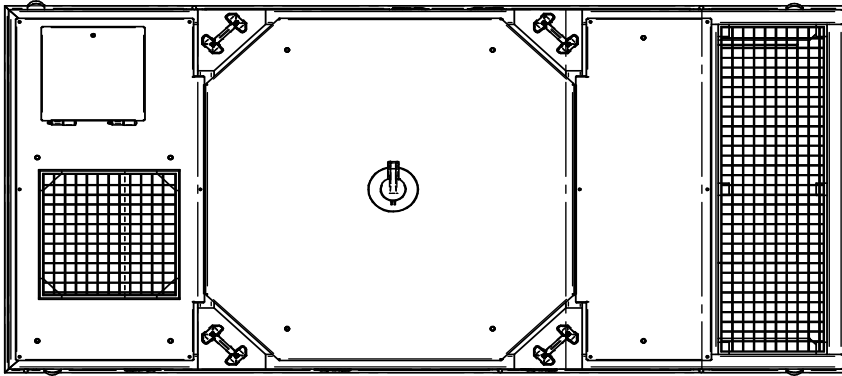
Specifications
PVE 200 XS STAGE V / TIER 4F

Diesel Engine	Caterpillar C7.1	
Max. theoretical power	186/249	kW/HP
Max. frequency	2,000	rpm
Max. operating pressure	5,076	psi
Hydraulic pump	Parker	
Max. oil flow	74	gal/min
Diesel Fuel	98	gal
DEF (AdBlue) capacity	9	gal
Hydraulic oil	132	gal
Weight without fuel	7,848	lbs
Weight with fuel	8,598	lbs