



DREDGING EQUIPMENT

2020



DREDGING EQUIPMENT

member of **DISEKO GROUP**





INDEX

BELL® PUMPS	4
• Overview	
• Characteristics	
• Production	
• Applications & Areas Of Operation	
STRONG POINTS	7
• Basic Design	
• Development	
• Spares & Services	
BELL® HEADS	10
• Sand Production Head	
• Flat Barge Head	
• Cutter Head	
• Auger Head	
• Double Cutter Head	
AVAILABLE OPTIONS	16
• Process Instrumentation	
• Production Instrumentation	
• Pipes, Hoses & Floats	
BELL® POWER PACKS	17
BELL® WATER JET PUMPS	18
BELL® BOOSTER STATIONS	19
BELL® DREDGE COMPUTER + SOUNDER SYSTEM	20
BELL® DREDGING PUMPS APP	21
BELL® A-FRAME DREDGER 250	21
BELL® CUTTER DREDGERS	22
• BCD 250 & 300	
• BCD 400	



**BELL®
PUMPS**

OVERVIEW



CHARACTERISTICS

	Units	BELL 100	BELL 150	BELL 200	BELL 250	BELL 300	BELL 400
Mixture capacity max	m ³ /h	300	500	800	1250	1800	3150
Pump speed max.	rpm	1350	1300	1200	900	750	600
Max power at shaft	kW	30	75	110	190	300	500
Pump head	m	40	55	65	65	65	65
Suction bore	Ø mm	100	150	200	250	300	400
Discharge piping	Ø mm	100	150	200	250	300	400
Spherical passage	mm	50	75	125	130	155	210
Weight (hydraulic, without head)	kg	550	950	1200	2000	3500	7750
Weight (electric, without head)	kg	1000	1375	1900	2900	4600	9150
Hydraulic Pressure	bar	250	250	250	250	300	300
Hydraulic Flow	L/min	85	195	290	475	600	1000
Hydraulic Cutter flow	L/min	15-20	15-20	35-50	35-50	70-110	140-210
Cutter power	kW	8.3	8.3	21	21	46	105



PRODUCTION

PRODUCTION DIAGRAM BELL PUMPS
(Medium Sand 230 μm)

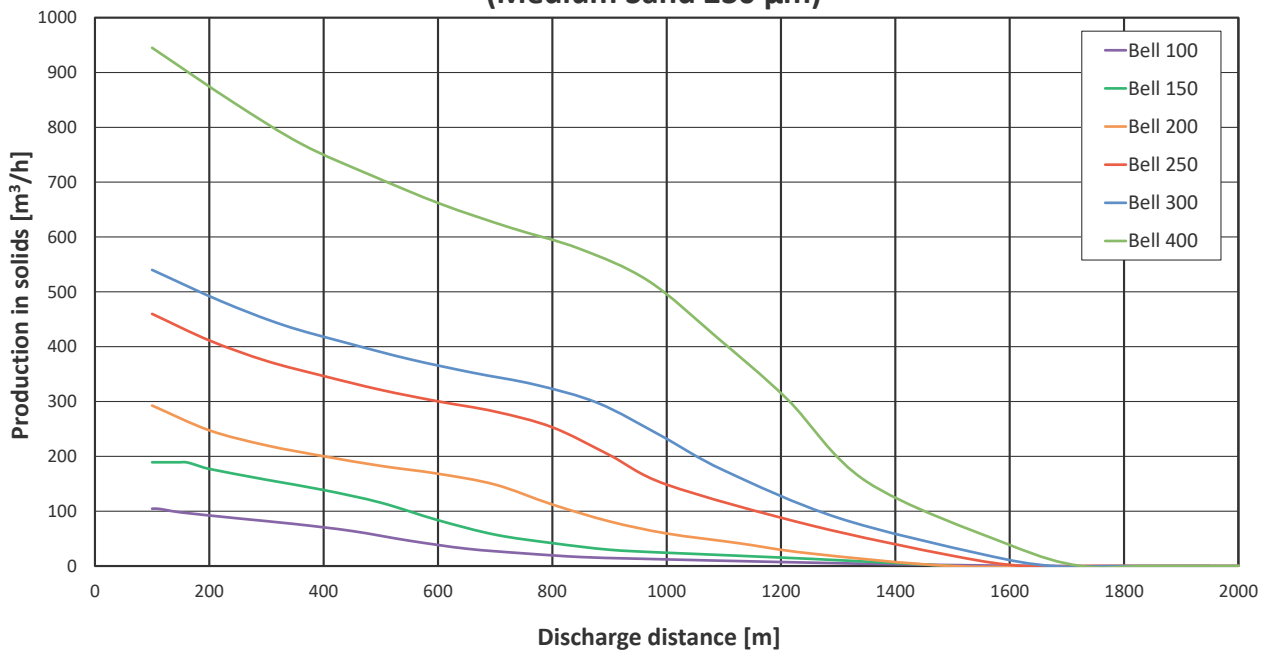

APPLICATIONS & AREAS OF OPERATION

Fields of application

- Environmental dredging
- Maintenance dredging
- Sand / gravel mining
- Mobile booster station
- Mounted on ladder of cutter suction dredger
- Suspension from A-frame
- Beach nourishment/reclamation dredging
- Free hanging on crawler crane
- Hopper barges

Typical areas of operation:

- Harbours
- Rivers
- Canals
- Restricted areas
- Sewage/power plants
- Emptying foundation piles







BASIC DESIGN

- Delivery from stock
- Heavy duty design
- Low maintenance
- Proven design
- Compact
- Multifunctional
- Low cost
- Large spherical passage
- Various suction heads available
- Changeable wear parts



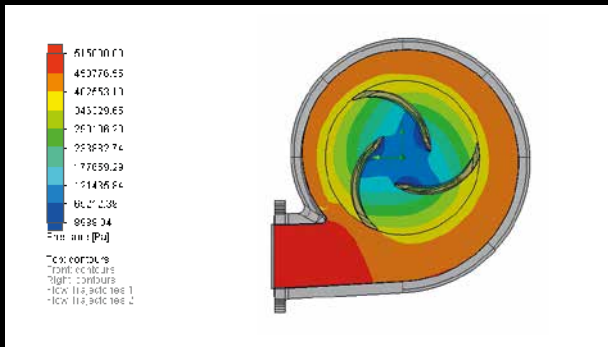

- **ADJUSTABLE NIHARD WEAR PLATES**
- **ADJUSTABLE NIHARD IMPELLER**
- **OPTIONAL SENSORS**



DEVELOPMENT

- Continuous improvement of pump design
- Flow simulations for higher efficiency
- Development of new suction heads and tools

SPARES AND SERVICES

After Sales Department:

- Components with short delivery time
- Complete package of spare parts
- Advice and support
- Experienced and dedicated team

Bell Field Service:

- Warranty and after sales services
- Training courses (in house and on site)
- Technical check-ups
- Service in remote areas
- Experienced operators

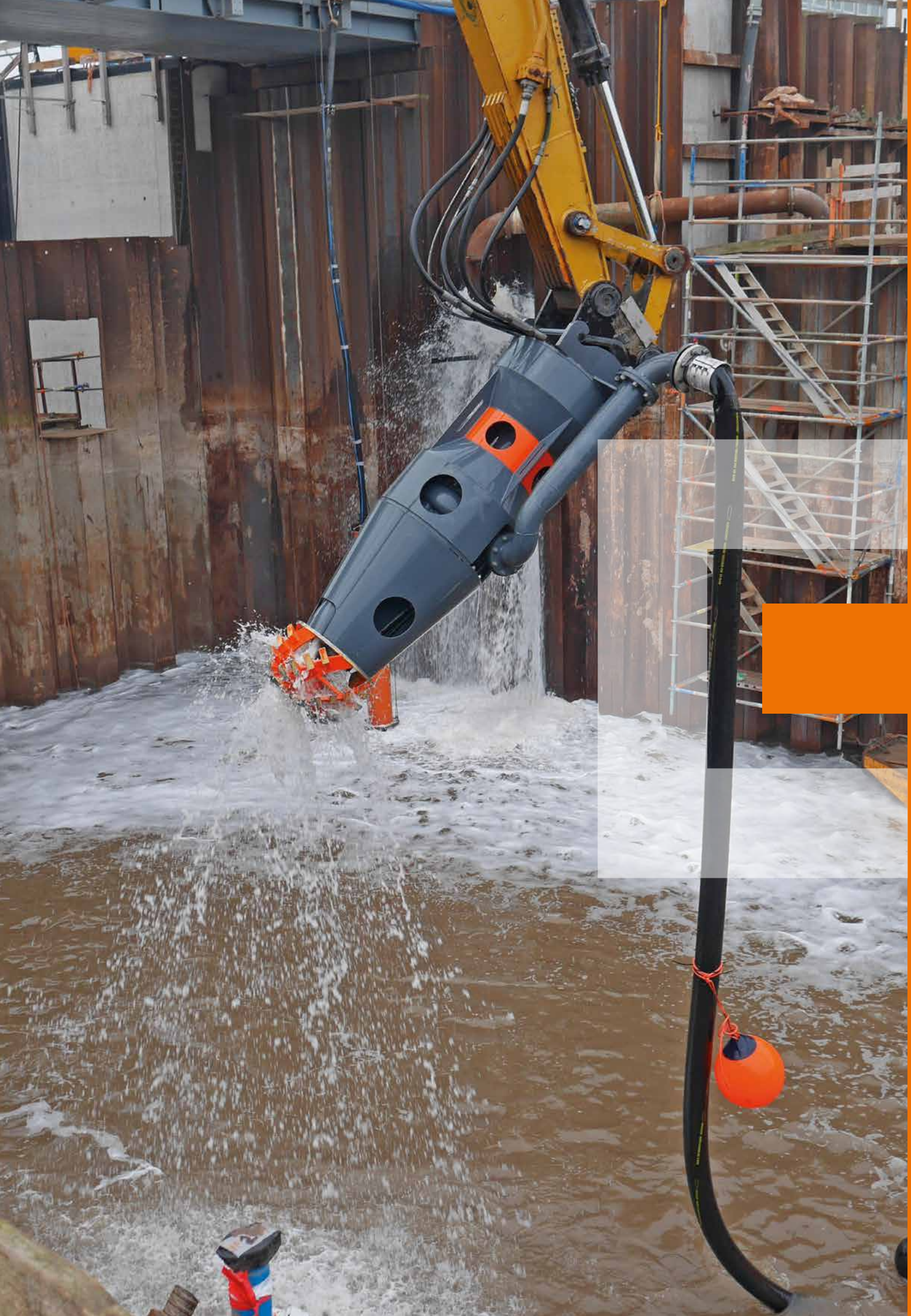



SAND PRODUCTION HEAD

FLAT BARGE HEAD

CUTTER HEAD

AUGER HEAD

DOUBLE CUTTER HEAD



SAND PRODUCTION HEAD

- Jet-water pipe and nozzles
- Suspension from crane or A-frame
- High production of solid material

FLAT BARGE HEAD

- Jet-water pipe and ring around head
- Suspension from crane or A-frame
- Emptying barges



CUTTER HEAD

- Separate hydraulic powered cutter
- Fixed suspension on crane or ladder
- Designed for cutting consolidated sand or clay



AUGER HEAD

- Dredging with minimal turbidity
- Used in polluted areas
- Less water is taken from the area
- Used for levelling soil under water
- High solids percentage

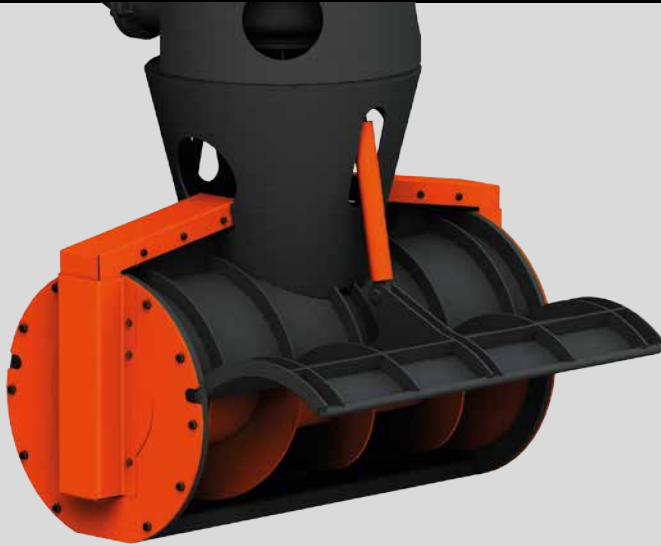





DOUBLE CUTTER HEAD

Thanks to the double cutter configuration, the pump can be used free-hanging from a cable, which is impossible with a normal, single cutter.

This set-up is the only free-hanging tool on the market that can both cut and pump simultaneously. In addition, the double cutter is also equipped with water jet nozzles in and around the rotating heads to keep them free of clay.



- Emptying foundation piles
- Suspension from cable/free hanging
- High hydraulic torque
- Cleaning pile wall with jet ring

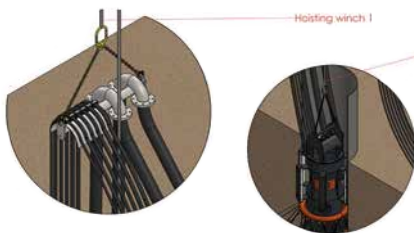

- BELL Hose Guide Beam
- Crawler Crane
- BELL Booster Station 100
- BELL Water Jet Pump 300
- BELL Hose Guide
- BELL Dredging Pump 100
- BELL Water Jet Ring
- BELL Double Cutter Head 100
- BELL Hydraulic Power Pack Stand-Alone 100

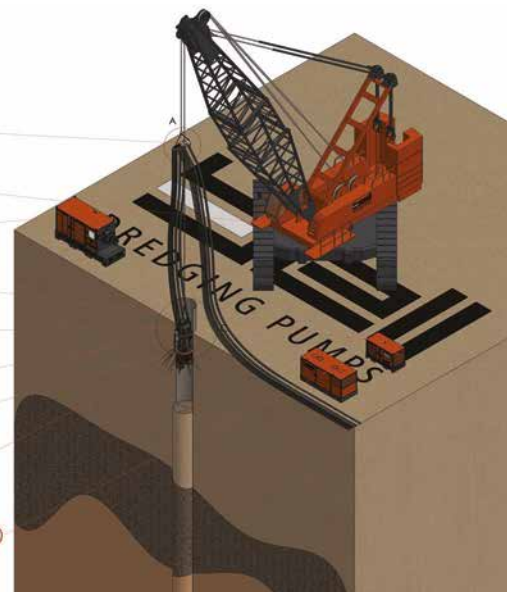

SPLITTERBOX

- Manometer on the dredging pump pressure line
- Manometer on the double cutter head pressure line
- Flow control valve and manual lever, all built into one box
- Hydraulic blockage protection & reverse system





PROCESS INSTRUMENTATION

BELL SENSORS

- Water ingress sensor
- Discharge pressure
- Pump speed
- Depth measurement



PRODUCTION INSTRUMENTATION

- Non-nuclear density meter
- Flow meter

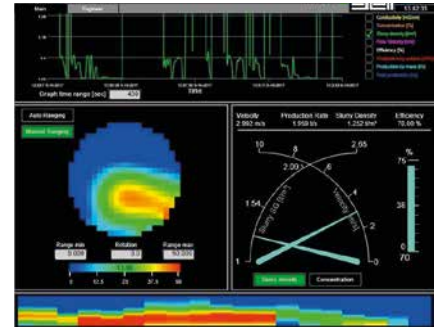

PIPES, HOSES AND FLOATS

- Discharge hoses including floats
- Discharge over land (Steel / HDPE)
- Self floating hoses
- Hydraulic hoses
- Jet-water hoses
- Geotubes





BELL® STAND-ALONE & AUXILIARY POWER PACKS AVAILABLE FOR ALL BELL DREDGING PUMPS & HEADS

	STAND-ALONE		
	AUXILIARY	FLOW 1	FLOW 2
BELL 100 POWER PACK	60 kW	85 L/min.	20 L/min.
BELL 150 POWER PACK	126 kW	195 L/min.	20 L/min.
BELL 200 POWER PACK	194 kW	290 L/min.	50 L/min.
BELL 250 POWER PACK	253 kW	475 L/min.	50 L/min.
BELL 300 POWER PACK	338 kW	600 L/min.	110 L/min.
BELL 400 POWER PACK	653 kW	1000 L/min.	110 L/min.

Auxiliary Power Packs have just one function to power the dredge pump. Stand-alone powerpacks have two functions to power both pump + pump head. Custom power packs with additional functions are also possible.





BELL® AUXILIARY POWER PACKS AVAILABLE FOR ALL BELL DREDGING PUMPS

BELL 150 AUXILIARY POWER PACK

- Power: 110 kW
- Flow: 195 L/min.

BELL 200 AUXILIARY POWER PACK

- Power: 129 kW
- Flow: 290 L/min.

BELL 250 AUXILIARY POWER PACK

- Power: 194 kW
- Flow: 475 L/min.

BELL® WATER JET PUMPS

BELL 100-200 WATERJET PUMP

- 120 m³/h
- 6-16 bar

BELL 250-300 WATERJET PUMP

- 270 m³/h
- 6-16 bar

BELL 400 WATERJET PUMP

- 480 m³/h
- 6-16 bar

- Diesel or hydraulic driven
- Fast dry priming
- On open skid or in closed sound-attenuated canopy
- Available for all Bell sand production heads and flat barge heads



BELL® BOOSTER STATIONS RANGE

When the discharge length needs to be increased, a Bell stand alone booster station can be added in the discharge line. This will ensure te productivity over the total required discharge length.

The Bell booster station can be either diesel-powered or electrically driven. For the diesel driven version, the pump is positioned on a frame with integrated diesel tank at the bottom. In the upper part of the frame multiple ventilation grids are installed as well as doors for access to the diesel engine. The pump itself is located outside of the canopy for easy access and connection of the discharge hoses.



BELL BOOSTER STATIONS	POWER
100	55 kW
150	96 kW
200	143 kW
250	237 kW
300	338 kW
400	560 kW

BELL® DREDGE COMPUTER + SOUNDER SYSTEM

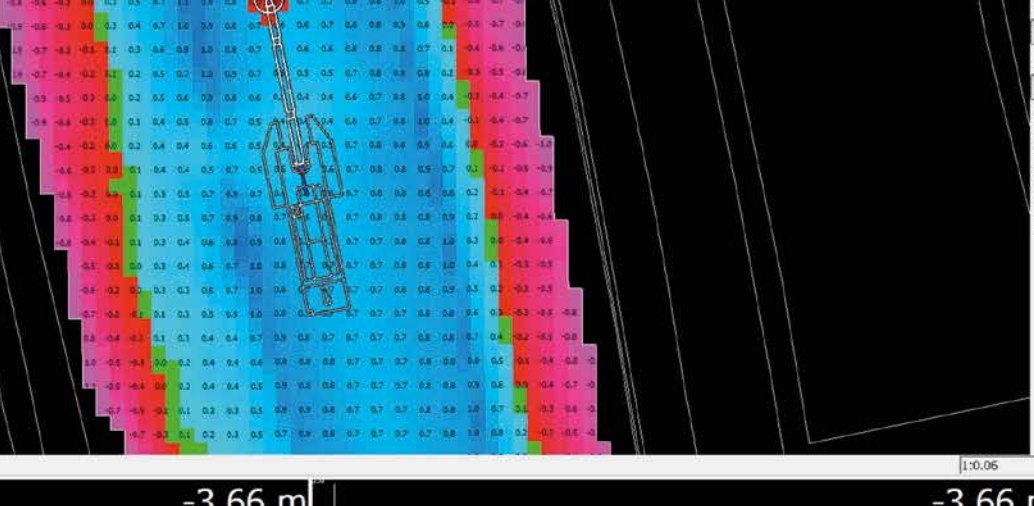

BELL® DREDGE COMPUTER

TYPICAL APPLICATIONS

- Cutter suction dredgers
- Grab dredgers
- (Amphibious) Excavators

SPECIFICATIONS

- Industrial Intel Computer
- Internal (G)PS/GLONASS (RTK) receiver
- Industrial GSM/GPRS/UMTS Modem
- CAN Sensor Interface
- IP67 9-30 VDC Power Input
- IP67 USB & Serial Connections
- IP67 Ethernet Connection
- Optional Internal UHF Transceiver
- Optional Internal GNSS Compass
- Wide range of accessories and sensors
- Dimensions: 40 x 23 x 11 cm

HARDWARE

- Internal industrial Intel PC with windows 7 Pro, SSD
- Internal Trimble RTK GPS/GLONASS 50 Hz with Heading
- Internal GSM/GPRS/UMTS/LTE Modem + Marine antenna
- AG Nevo X15 LCD + LCD Arm
- Mini keyboard/Trackball combo

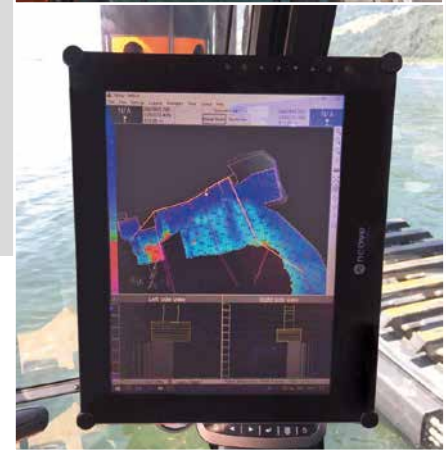

BELL® SOUNDER SYSTEM

BELLSounder is designed to be a simple and rugged hydrographical survey solution with the basic functions of an echo sounder. Depending on the connected sensors, BELLSounder will function as a dual or a single frequency echo sounder. Powered by either an internal Trimble or a Hemisphere GNSS receiver, it provides the perfect solution for a hydrographic survey solution. The BELLSounder consists of a rugged Peli Case that provides a protected housing for every environment.



BELL®
DREDGING
PUMPS APP



BELL® DREDGING PUMPS APP

Thanks to our newly developed application, it is now possible to remotely control your booster station, power pack or water jet pump. Imagine you have 3 mile long discharge pipe line with multiple booster stations in between. With the Bell app on your phone or tablet you can now start up, monitor and control all the booster stations without leaving the cabin of your excavator or dredger. Any notifications like fuel level or oil pressure will be shown on the screen, so you can take action much sooner when one gets critical.

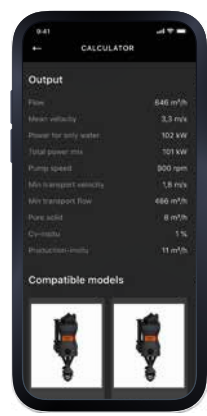
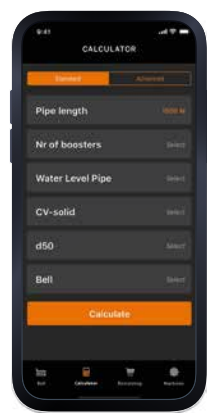
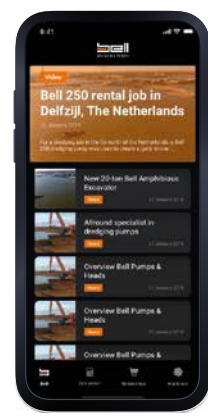

A-FRAME DREDGER 250

MAIN SPECIFICATIONS

Length	12.192 mm
Width	7.376 mm
Height	6.090 mm
Design draught	607,2 mm
Total weight	± 35.000 kg
Total installed power	516 kW
Max river flow rate	3 m/s

DREDGING PUMP SPECIFICATIONS

Dredging pump	BELL 250
Max mixture capacity	1250 m³/h
Pump speed	900 rpm
Max power at shaft	190 kW





BELL CUTTER DREDGERS 250 & 300



BELL CUTTER DREDGER 250

- Dredge pump: BELL 250
- Dredge capacity (water & solids): 1250 m³/hr
- Dredge capacity in dry volume (max.): 250 m³/hr
- Stone size diameter (max.): 130 mm
- Installed power on the dredge pump: 190 kW
- Power source dredger: Diesel engine
- Positioning entities: 2x mooring winches & 2x spud poles

BELL CUTTER DREDGER 400

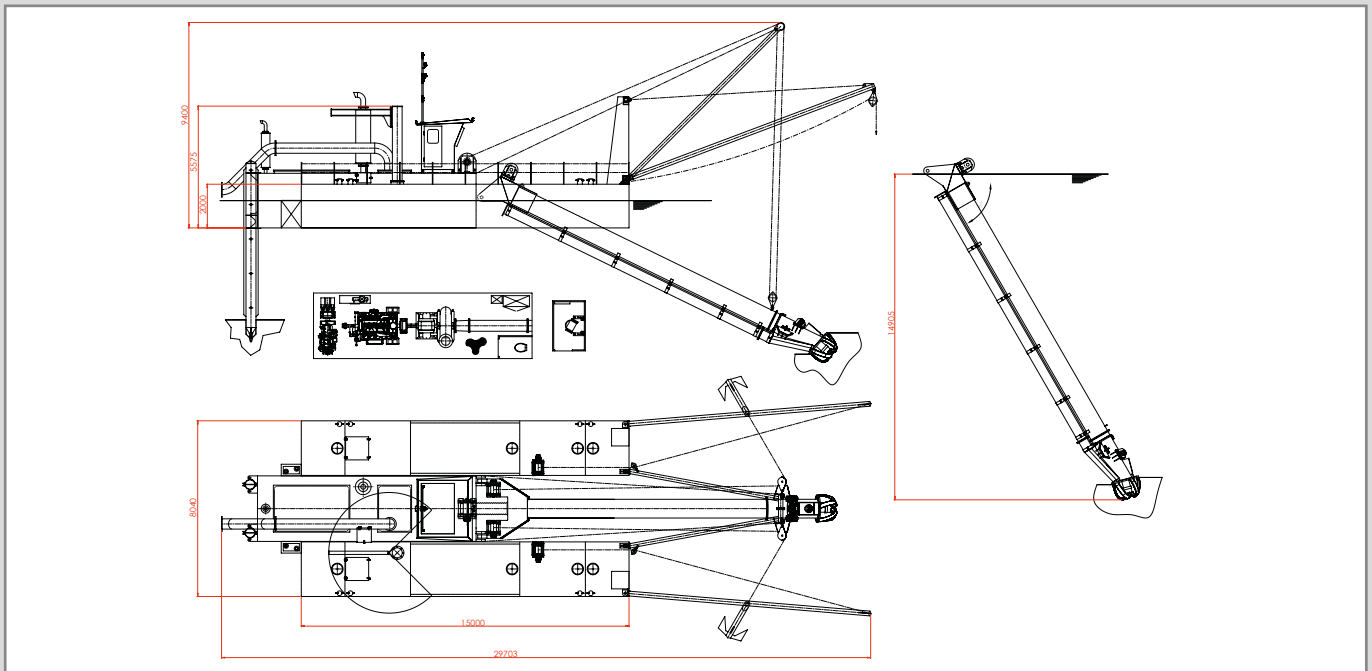

BELL CUTTER DREDGER 400

- Dredge pump: BELL 400
- Dredge capacity (water & solids): 3150 m³/hr
- Dredge capacity in dry volume (max.): 630 m³/hr
- Stone size diameter (max.): 210 mm
- Installed power on the dredge pump: 500 kW
- Power source dredger: Diesel engine
- Positioning entities: 2x mooring winches & 2x spud poles

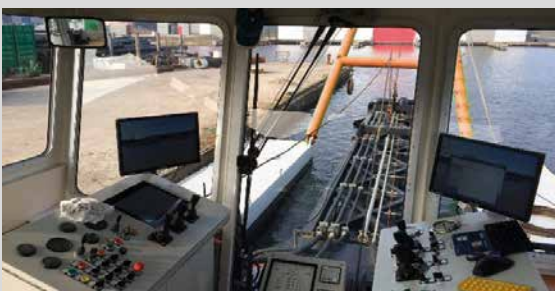



member of **DIESEKO GROUP**

MORE INFORMATION:
BELLDREDGING.COM

Bell Dredging Pumps B.V. | Winkelerzand 1a | 1731 LR Winkel, the Netherlands | Telephone: +31(0)224-855 340
www.BellDredging.com | info@BellDredging.com | VAT: NL8522.96.964 | COC: 56 77 52 45

012020-EN

Dealer:

