

Accessories for Clamshell Buckets

KM 680 - Scrapers

Scrapers for clamshell buckets with narrow widths clear the inside of the shells of sticky materials such as clay, during each opening. The design varies depending on the grapple.

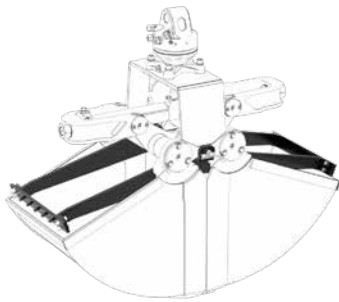

Type For clamshell bucket

KM 680 01	KM 603/ 604/ 604HPX/ 605/ 605HPX/ 606/ 607
KM 680 02	KM 626HPX / KM 626
KM 505 04	link-set for KM 604HPX/605HPX/626HPX in combination with KM 505 / KM 505 HD and scraper KM 680



link for the combination
KM 505 (HD) + HPXdrive + scraper

KM 685 05 - Adapter for compression rails and compression rails

Adapters enable mounting of compression rails or support for concrete rings, for handling paving slabs, curbstones, concrete rings etc. The adapters can only be used with a **non-return valve**. They are not suitable for the use with a scraper.

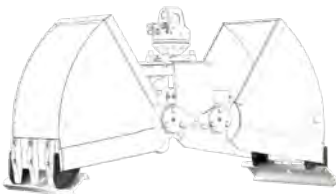

Type Description

KM 685 05	adapters for compression rails (Load capacity max. 250 kg)
KM 381 09 (720)	compression rails – length 720 mm lang (2 pieces)
KM 381 09 (1000)	compression rails – length 1000 mm lang (2 pieces)

The adapters for compression rails are available for the following clamshell buckets:
KM 603/ 604/ 604HPX/ 604U HPX/ 605/ 605U/ 605HPX/ 605U HPX/ 606

KM 685 06 - Central lifting devices for HPXdrive, welded hooks and welded eyes

KM 685 06 hook

The central lifting device for HPXdrive, welded eyes or welded hooks suit lifting chains or slings. The max. capacity per eye or hook is 1000 kg.



KM 685 06 HPX

Type Description

KM 685 06 HPX SD	to suit lifting chain or sling, 1 piece
KM 685 06 HPX HD	to suit lifting chain or sling, 1 piece
KM 685 06 hook	to suit lifting chain or sling, 1 piece
KM 685 06 hook set 2	to suit lifting chain or sling, 2 pieces
KM 685 06 hook set 4	to suit lifting chain or sling, 4 pieces
KM 685 06 eye	to suit lifting chain or sling, 1 piece
KM 685 06 eye set 2	to suit lifting chain or sling, 2 pieces



central lifting device HPXdrive



welded hook



welded eye
(not for HPX)

KM 685 07 - Wear plates (2 pcs.)

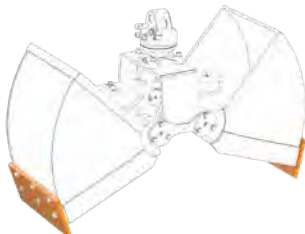

Type Description

KM 685 07 set	Wear plates, 2 pieces, to protect horizontal cutting edges
----------------------	--

KM 685 08 - Extension for excavation works with the HPXdrive Standard or the HPXdrive Heavy Duty



Type Description

KM 685 08 HPX-450	HPXdrive extension for excavating e.g. trenches (for canal and civil engineering) – 450 mm (30 kg)
--------------------------	--

KM 501 - Upper suspension between rotator and crane

An upper suspension is a cardan link between rotator and crane. It is available for all current makes and models of cranes. Please specify dimensions when ordering.

Type	Load capacity (kg)	Self weight (approx. kg)
KM 501 (3000)	up to 3000	5
KM 501 (4500)	up to 4500	10
KM 501 (6000)	up to 6000	15
KM 501 (10,000)	up to 10000	25



KM 511 - Upper suspension with pendulum damper between rotator and crane

A pendulum damper reduces the horizontal swing of the attachment. It can also be retrofitted to an existing upper suspension.

Type	Load capacity (kg)	Self weight (approx. kg)
KM 511 (4500)	up to 4500	15
KM 511 (6000)	up to 6000	20
KM 511 (10,000)	up to 10000	30



KM 206 - Hose guard

The hose guard is a metal bow to be attached onto the rotator. It is designed to protect the hoses of the rotator from damage i.e. from protruding branches.

Type	Description	Self weight (approx. kg)
KM 206	hose guard for the rotator	3



KM 502 - Reduction link between rotator and grapple

A reduction link adapts a shaft type rotator to an attachment with a standard hole pattern for a flange (KM 502).

Type	Load capacity (kg)	Self weight (approx. kg)
KM 502 (3000)	up to 3000	2
KM 502 (4500)	up to 4500	3
KM 502 (6000)	up to 6000	4



KM 460 - Accessories for Attaching Pallet Forks with shaft rotator

Type	Description	Type of rotator	Weight (approx. kg)
KM 460 03 (KM 03 S)	rigid suspension link with pin for all KINSHOFER shaft-type rotators	KM 03	8
KM 460 03 (KM 04 S)		KM 04	10
KM 460 08 (KM 03 S)	rigid hook for all KINSHOFER shaft rotators	KM 03	8
KM 460 08 (KM 04 S)		KM 04	9
KM 460 04 (KM 04 S)	non-rotating swinging hook for all KINSHOFER shaft rotators	KM 04	12
KM 460 04 (KM 06 S)		KM 06	15
KM 460 10	non-rotating swinging hook for all KINSHOFER flange rotators	KM 10 F173	25



KM 460 03



KM 460 04

KM 505 - Quick change system for shaft-type rotators up to 4000 kg load capacity

The quick change system enables an easy exchange between different attachments. The mechanical coupling and locking is achieved by the turning motion of the rotator. You simply disconnect the quick couplings and disengage the locking device manually. The upper element of the quick change system is available for all KM 04 - shaft rotators. The KM 505 system allows the easy exchange between pallet fork and brick stack grapple for example; not suitable for heavy duty work.



Type	Description	Hole pattern of flange (mm)	Self weight (kg)
KM 505	complete, incl. hydraulic couplings (KM 204 03)	4x Ø18 / □ 140	12
KM 505 01	upper element fitted to rotator incl. mobile and fixed parts		5
KM 204 01	mobile part of hydraulic quick coupling (2 pieces) for KM 505 01		
KM 505 02	lower element mounted to the attachment	4x Ø18 / □ 140	7
KM 505 03	rigid suspension link with non-rotating hook to connect to the KM 505 01		7
KM 505 05	distance ring between KM 505 and KM 461 universal fork		5



KM 505 01



KM 505 02



KM 505 03

KM 505 HD - Heavy duty quick change system for shaft-type rotators

The quick change system enables an easy exchange between different attachments. The mechanical coupling and locking is achieved by the turning motion of the rotator. You simply disconnect the quick couplings and disengage the locking device manually. The upper element of the heavy duty quick change system is available for the KINSHOFER shaft rotators KM 04 S68-30US or KM 06 S68-40. The KM 505 system allows the easy exchange between pallet fork and clamshell bucket for example; especially developed for the heavy duty task with clamshell buckets.



Type	Description	Hole pattern of flange (mm)	Self weight (kg)
KM 505 HD	complete, incl. hydraulic couplings (KM 204 03)	4x Ø18 / □ 140	18
KM 505 01 HD	upper element HD fitted to rotator incl. mobile and fixed parts		7
KM 204 01	mobile part of hydraulic quick coupling (2 pieces) for KM 505 01 HD		
KM 505 02 HD	lower element HD mounted onto attachment	4x Ø18 / □ 140	11
KM 505 03 HD	rigid suspension link with non-rotating hook to connect to the KM 505 01 HD		14
KM 505 05	distance ring between KM 505 HD and KM 461 universal fork		5



KM 505 01 HD



KM 505 02 HD



KM 505 03 HD

KM 203 - Connecting hoses / KM 204 - Hydraulic quick change kit for hoses

KM 203 01



Type	Description
KM 203 01	short connecting hoses between rotator and attachment with standard fittings M 18 x 1,5 (2 pieces)
KM 203 03	long connecting hoses between rotator and crane. Please specify dimensions (4 pieces)



KM 204 03

KM 204 01	mobile part of hydraulic quick coupling for hose (Ø 10 mm, 2 pieces)
KM 204 02	fixed part of hydraulic quick coupling for rotator (Ø 10 mm, 2 pieces)
KM 204 03	hydraulic quick change kit incl. mobile and fixed parts (2 pieces each) mounted with adapters to rotator

Compression rails

	Type	Description	Length (mm)	Weight (kg)
	KM 381 29 (720)	compression rails with smooth rubber inserts (2 pieces)	720	17
	KM 381 29 (1000)		1000	24
	KM 381 29 (1250)		1250	28
	KM 381 39 (720)	compression rails with two rubber inserts, upper insert contoured, lower insert smooth (2 pieces each)	720	24
	KM 381 39 (1000)		1000	33
	KM 381 39 (1250)		1250	42
	KM 381 32 (1000)	spring loaded rails with parallel-action teeth (2 pieces) fitted within seconds by locking lever	1000	62
	KM 381 32 (1250)		1250	76
	KM 381 09 (720)	compression rails for adapter KM 381 38 (2 pieces)	720	17
	KM 381 09 (1000)		1000	23
	KM 381 09 (1250)		1250	28
	KM 381 38	adapter for clamping arms to take compression rails KM 381 09		40

Please note: additional lengths of compression rails are available on request.

Others

Non-standard opening range: all grapples are available with opening ranges not listed
Non-standard plunge depth: all grapples are available with plunge depth not listed

KM 381 08 S



Type	Description	Weight (kg)
KM 381 08 S	tilting device to reduce overall height of the equipment in transport	12
KM 381 08 F	tilting device to reduce overall height of the equipment in transport	18



KM 381 18	height reduction link to reduce the overall height of the equipment in transport - for flange rotators	15
-----------	--	----



KM 381 05	height stop for quick adjustment of plunge depth	8
KM 381 06	spring loaded guide rails for stabilizing the top layer of the stack	---
KM 381 07	spring loaded guide plates for lateral stabilizing of the stack	---
KM 381 31	adapter for concrete pipes with diameters from 800 to 1350 mm	60