

Universal clamshell bucket with the *HPXdrive* for compact excavators from 3t/6600lbs to 6t/13200lbs operating weight - low maintenance.

- ▷ ***HPXdrive* - the revolutionary concept for hydraulically operated grabs!**
The rotation of the arms of the grab is generated by two hollow shafts, which run opposed and have a helix thread, hydraulically driven by a single piston.
No hydraulic cylinder required.
- ▷ **50% longer life cycle.** The drive unit runs in a permanent oil bath – no lubrication necessary. Resistant against dirt and blows due to the compact design.
- ▷ **Constant closing forces** during the entire digging process (25kN/5500lbf at an internal operating pressure of 26MPa/3770psi; varies depending on width).
- ▷ Different applications possible thanks to **shell exchange system.**
- ▷ **Long life** is ensured due to the use of 500 HB steel in the manufacture of cutting edges.

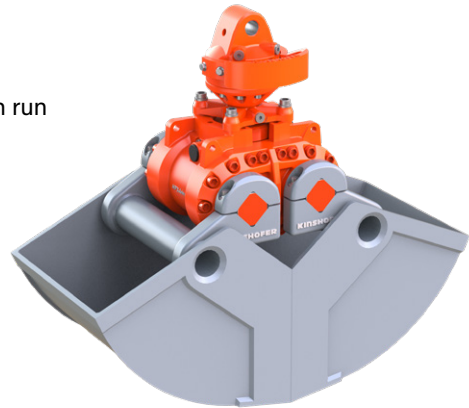

Clamshell Bucket C05HPX							
Type	Width E (mm/in)	Opening A (mm/in)	Height C max. (mm/in)	Volume (liter/c.y.)	Number of teeth	Weight (kg/lbs)	Load capacity (kg/lbs)
C05HPX-40	400 / 15.7	1110 / 43.7	880 / 34.6	115 / 0.15	4	270 / 594	3000 / 6600
C05HPX-45	450 / 17.7	1110 / 43.7	880 / 34.6	130 / 0.17	4	285 / 627	3000 / 6600
C05HPX-50	500 / 19.6	1110 / 43.7	880 / 34.6	140 / 0.18	4	290 / 638	3000 / 6600
C05HPX-60	600 / 23.6	1110 / 43.7	880 / 34.6	170 / 0.22	6	305 / 671	3000 / 6600
C05HPX-80	800 / 31.4	1110 / 43.7	880 / 34.6	230 / 0.30	6	330 / 726	3000 / 6600

Package consists of: clamshell bucket, bolt-on teeth, **KINSHOFER** rotator, non-return valve and hose protection

Note: exchangeable shells see page 50 in this catalog. Special shells on request

KINSHOFER Rotator

Integrated in a single unit with the *HPXdrive*, no more connecting hoses. Continuous rotation. Overload protection ensured by pressure relief valves.

Type	Upper dimension (width x pin-Ø) (mm/in)	Torque (Nm/ft.lbs)	Bending moment max. (Nm/ft.lbs)
KM 04 F140-30VE	84 x 30 / 3.3 x 1.1	850 / 626	3000 / 2212

Accessories

Type	Description
KM 501 1t-8t	upper suspension without pendulum damper
KM 511 1t-8t	upper suspension with pendulum damper
KM 510 1t-8t	single pendulum damper to upgrade the upper suspension KM 501 1t-8t / 2200-17600lbs
KSW03 cardanic	adapter for system L-Lock KMS03L/KHS03L incl. cardan link excl. pendulum damper – up to 6t / 13200lbs
KSW03 cardanic-P	adapter for system L-Lock KMS03L/KHS03L incl. cardan link incl. pendulum damper – up to 6t / 13200lbs
	adapters for quick change systems from other manufacturers or different sizes on request
KM 680 5t-8t	scraper
KM 685 06E hook set 2	welded hooks (2 pcs.)
KM 685 07E set	wear plates to protect cutting edges
KM 685 08 HPX 450E	digging extension for channel construction – 450mm / 17.7in (60kg / 132lbs)

Requirements of carrier machine

Operating pressure at pump capacity (open/close):

26 MPa (260 bar) at max. 75 l/min / 3745 psi at max. 20 GPM
26 - 32 MPa (260 - 320 bar) at max. 40 l/min / 3745 - 4640 psi at max. 10.6 GPM

Operating pressure at pump capacity (rotate):

32 MPa (320 bar) at 15 - max. 50 l/min / 4640 psi at 4 - max. 13 GPM

Technical drawings

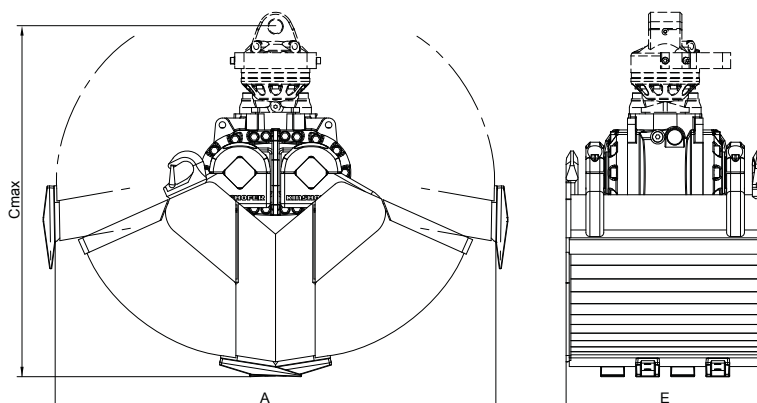

Free extension
of warranty
kinshofer.com/service