

Clamshell Bucket with exchangeable shells and vertical cylinders for excavators from 9t/19800lbs to 12t/19800lbs operating weight - through quick and easy exchange of shells, the C12VE is ideal for different applications, for excavation operations, landscaping, trench digging, handling of logs and more. The shells can be changed in less than four minutes.

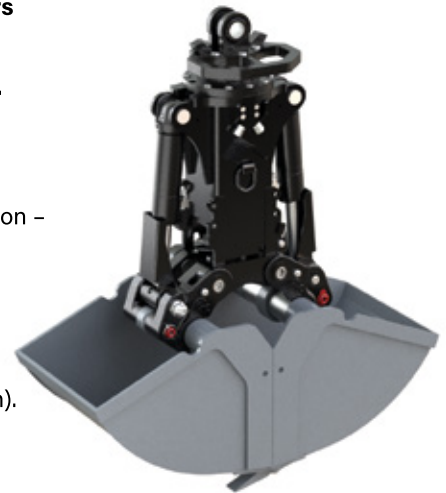

- ▷ **Economic solution** as only the shells have to be exchanged for another application - bucket carrier, hydraulic cylinder and bearings are integrated into the unit.
- ▷ **Long life** is ensured due to the use of 500 HB steel in the manufacture of cutting edges.
- ▷ **Reduced wear** resulting from generously dimensioned bearing system.
- ▷ **Excellent digging characteristics** are the result of high closing forces (39kN/8580lbf at 32MPa/4640psi operating pressure; varies depending on width).

Clamshell Bucket C12VE								
Type	Width E (mm/in)	Opening A (mm/in)	Height C max.(mm/in)	Length F (mm/in)	Volume (liter/c.y.)	Number of teeth	Weight (kg/lbs)	Load capacity (kg/lbs)
C12VE-32	325 / 12.7	1645 / 64.7	1570 / 61.8	1350 / 53.1	125 / 0.16	3	475 / 1045	4500 / 9900
C12VE-40	400 / 74.1	1645 / 64.7	1570 / 61.8	1350 / 53.1	160 / 0.21	3	485 / 1067	4500 / 9900
C12VE-50	500 / 19.6	1645 / 64.7	1570 / 61.8	1350 / 53.1	200 / 0.26	5	500 / 1100	4500 / 9900
C12VE-60	600 / 23.6	1645 / 64.7	1570 / 61.8	1350 / 53.1	245 / 0.32	5	515 / 1133	4500 / 9900
C12VE-70	700 / 27.5	1645 / 64.7	1570 / 61.8	1350 / 53.1	285 / 0.37	7	525 / 1155	4500 / 9900
C12VE-80	800 / 31.4	1645 / 64.7	1570 / 61.8	1350 / 53.1	330 / 0.43	9	535 / 1177	4500 / 9900

Package consists of: clamshell bucket, bolt-on teeth, **KINSHOFER** rotator with hose guard, 2 weld-on eyes, shell exchange aid kit and non-return valve

KINSHOFER Rotator

Continuous rotation and two oil passages. Overload protection is ensured by pressure relief valves.

Type	Upper dimension (width x pin-Ø) (mm/in)	Torque (Nm/ft.lbs)	Bending moment max. (Nm/ft.lbs)
KM 10 F275-50	110 x 50 / 4.3 x 1.9	2000 / 1475	14000 / 10325

Accessories

Type	Description
KM 501 9t-12t	upper suspension without pendulum damper
KM 511 9t-12t	upper suspension with pendulum damper
KM 510 9t-12t	single pendulum damper to upgrade the upper suspension KM 501 9t-12t / 19800-26400lbs
KSW08 cardanic	adapter for system L-Locks KMS08L/KHS08L incl. cardan link excl. pendulum damper - up to 12t / 26400lbs
KSW08 cardanic-P	adapter for system L-Locks KMS08L/KHS08L incl. cardan link incl. pendulum damper - up to 12t / 26400lbs
KSW10 cardanic	adapter for system L-Lock KMS10L/KHS10L incl. cardan link excl. pendulum damper - up to 19t / 41800lbs
KSW10 cardanic-P	adapter for system L-Lock KMS10L/KHS10L incl. cardan link incl. pendulum damper - up to 19t / 41800lbs
KM 680 C12VE	scraper

Requirements of carrier machine

Operating pressure (open/close):	max. 32 MPa (320 bar) / 4640 psi
Recommended pump capacity (open/close):	40 - max. 120 l/min / 10.5 - max. 32 GPM
Operating pressure (rotate):	max. 32 MPa (320 bar) / 4640 psi
Recommended pump capacity (rotate):	20 - max. 50 l/min / 5 - max. 13 GPM

Technical drawing

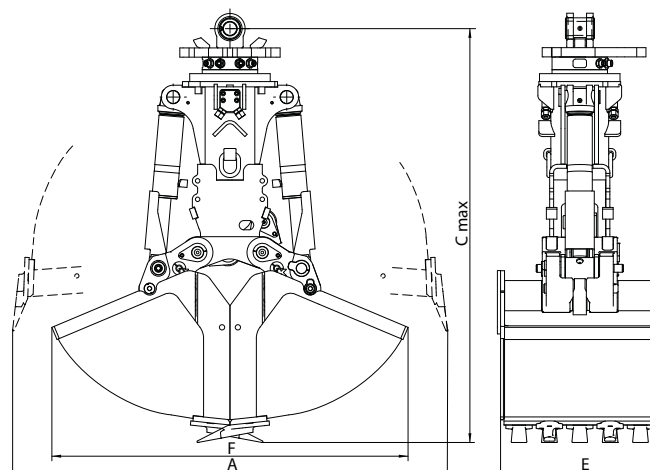

Exchangeable Shells for C12VE

Exchangeable shells for C12VE

Shells are interchangeable and available in all widths. Rapid exchange with shell stand and pin exchange tool.

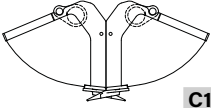
Type	Width (mm/in)	Opening (mm/in)	Height complete (mm/in)	Volume (liter/c.y.)	Number of teeth	Weight shells (kg/lbs)	Loading capacity (kg/lbs)	Closing force (kN/lbf)
Clamshell Bucket								
								
C12VE-32S	325 / 12.7	1535 / 60.4	1570 / 61.8	125 / 0.16	3	130 / 286	4500 / 9900	39 / 8580
C12VE-40S	400 / 15.7	1535 / 60.4	1570 / 61.8	160 / 0.21	3	140 / 308	4500 / 9900	39 / 8580
C12VE-50S	500 / 19.6	1535 / 60.4	1570 / 61.8	200 / 0.26	5	165 / 363	4500 / 9900	39 / 8580
C12VE-60S	600 / 23.6	1535 / 60.4	1570 / 61.8	245 / 0.32	5	180 / 396	4500 / 9900	39 / 8580
C12VE-70S	700 / 27.5	1535 / 60.4	1570 / 61.8	285 / 0.37	7	205 / 451	4500 / 9900	39 / 8580
C12VE-80S	800 / 31.4	1535 / 60.4	1570 / 61.8	330 / 0.43	9	225 / 495	4500 / 9900	39 / 8580

Excavating Grab

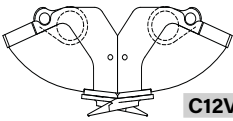

C12VE-32S EG	325 / 12.7	1200 / 47.2	1350 / 53.1	90	3	110 / 242	4500 / 9900	52 / 11440
C12VE-40S EG	400 / 15.7	1100 / 43.3	1355 / 53.3	55	3	125 / 275	4500 / 9900	55 / 12100
C12VE-80S EG	800 / 31.4	800 / 31.4	1350 / 53.1	100	9	155 / 341	4500 / 9900	63 / 13860

Pipe Grab

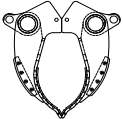

C12VE-80S PG	800 / 31.4	Ø75-560 / Ø2.9-22	1590 / 62.5	-	-	145 / 319	4500 / 9900	39 / 8580
---------------------	------------	----------------------	-------------	---	---	-----------	-------------	-----------

Well Shaft Grab



C12VE-100S WSG	Ø1000 / Ø39.3	1000 / 39.3	1320 / 51.9	100 / 0.13	5	140 / 308	4500 / 9900	60 / 13200
-----------------------	------------------	-------------	-------------	------------	---	-----------	-------------	------------

Note: larger shells available on request

Hay and Forestry Grab

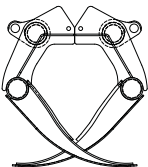

A12VE-94S	940 / 37	1850 / 72.8	1695 / 66.7	400 / 0.52	-	205 / 451	4500 / 9900	39 / 8580
A12VE-122S	1220 / 48	1850 / 72.8	1695 / 66.7	600 / 0.78	-	240 / 528	4500 / 9900	39 / 8580

Rock Grab

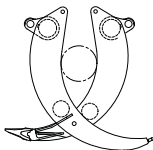

R12VE-48S	480 / 18.8	1850 / 72.8	1790 / 70.4	0,50 m ² / 33.5 cord	-	200 / 440	4500 / 9900	30 / 6600
------------------	------------	-------------	-------------	------------------------------------	---	-----------	-------------	-----------

Timber Grab

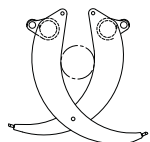

T12VE-47S	470 / 18.5	1835 / 72.2	1795 / 70.6	0,50 m ² / 33.5 cord	-	180 / 396	4500 / 9900	30 / 6600
------------------	------------	-------------	-------------	------------------------------------	---	-----------	-------------	-----------

Rail Tines

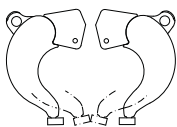

C12VE-50S RG	500 / 19.6	1350 / 53.1	1405 / 55.3	-	-	135 / 297	4500 / 9900	44 / 9680
---------------------	------------	-------------	-------------	---	---	-----------	-------------	-----------

Package consists of: shells, teeth (for clamshell bucket, excavating and well shaft grab), shell exchange aid kit and pin extraction tool

Note: special shells on request