

Clamshell Bucket with exchangeable shells and vertical cylinders for excavators from 13t/28600lbs to 18t/39600lbs operating weight - through quick and easy exchange of shells, the C18VE is ideal for different applications, for excavation operations, landscaping, trench digging, handling of logs and more. The shells can be changed in less than four minutes.

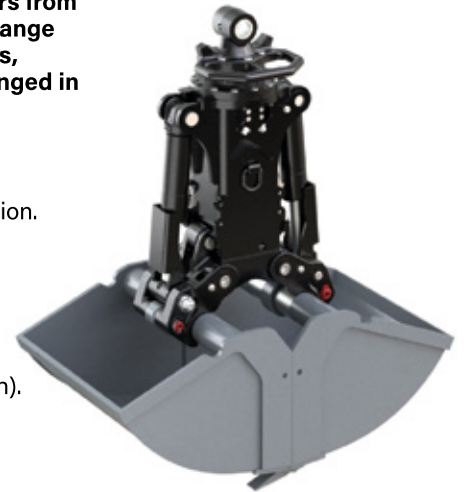

- ▷ **Economic solution** as only the shells have to be exchanged for another application. Bucket carrier, hydraulic cylinder and bearings are integrated into the unit.
- ▷ **Long life** is ensured due to the use of 500HB steel in the manufacture of cutting edges.
- ▷ **Reduced wear** resulting from generously dimensioned bearing system.
- ▷ **Excellent digging characteristics** are the result of high closing forces (42kN/9240lbf at 35MPa/5070psi operating pressure, varies depending on width).

### Clamshell Bucket C18VE

Type	Width	Opening	Height	Length	Volume	Number of teeth	Weight (kg/lbs)	Load capacity (kg/lbs)
	E (mm/in)	A (mm/in)	C max.(mm/in)	F (mm/in)	(liter/c.y.)			
C18VE-33	335 / 13.2	1655 / 65.2	1595 / 62.8	1360 / 53.5	125 / 0.16	3	590 / 1298	4500 / 9900
C18VE-40	400 / 15.8	1655 / 65.2	1595 / 62.8	1360 / 53.5	160 / 0.21	3	605 / 1331	4500 / 9900
C18VE-50	500 / 19.7	1655 / 65.2	1595 / 62.8	1360 / 53.5	200 / 0.26	5	630 / 1386	4500 / 9900
C18VE-60	600 / 23.6	1655 / 65.2	1595 / 62.8	1360 / 53.5	245 / 0.32	5	655 / 1441	4500 / 9900
C18VE-80	800 / 31.5	1655 / 65.2	1595 / 62.8	1360 / 53.5	330 / 0.43	9	705 / 1551	4500 / 9900
C18VE-100	1000 / 39.4	1655 / 65.2	1595 / 62.8	1360 / 53.5	415 / 0.54	9	755 / 1661	4500 / 9900

**Package consists of:** clamshell bucket, bolt-on teeth, **KINSHOFER** rotator with hose guard, 2 weld-on eyes, shell exchange aid kit and non-return valve

### KINSHOFER Rotator

Continuous rotation and two oil passages. Overload protection is ensured by pressure relief valves.

Type	Upper connection (width x pin-Ø) (mm/in)	Torque (Nm/ft.lbs)	Bending moment max. (Nm/ft.lbs)
KM 10 F275-60	125 x 60 / 4.9 x 2.4	1500 / 1106.3	14000 / 10325

### Accessories

Type	Description
KM 501 13t-25t	upper suspension without pendulum damper
KM 511 13t-25t	upper suspension with pendulum damper
KM 510 13t-25t	single pendulum damper
KSW10 cardanic	adapter for system L-Lock KMS10L/KHS10L incl. cardan link excl. pendulum damper - up to 19t/41800lbs
KSW21/25 cardanic	adapter for system L-Lock KMS21/25L / KHS21/25L incl. cardan link excl. pendulum damper - up to 40t/88000lbs
	adapters for quick change systems from other manufacturers or different sizes on request
KM 680 C18VE	scraper

### Requirements of carrier machine

<b>Operating pressure (open/close):</b>	<b>max. 35 MPa (350 bar) / 5070psi</b>
<b>Recommended pump capacity (open/close):</b>	75 - max. 150 l/min / 20 - max. 40GPM
<b>Operating pressure (rotate):</b>	<b>max. 32 MPa (320 bar) / 4640psi</b>
<b>Recommended pump capacity (rotate):</b>	20 - max. 50 l/min/ 5 - max. 13GPM

### Technical drawing

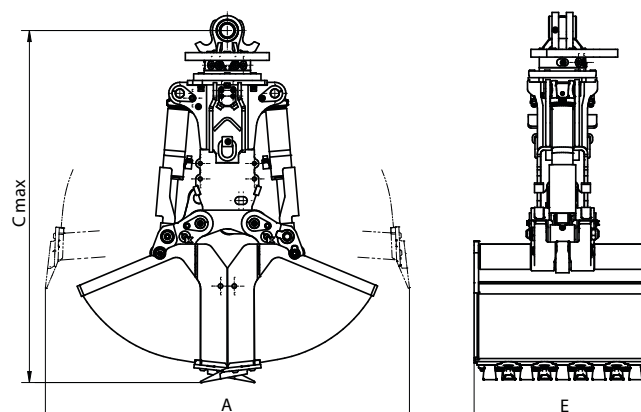

# Exchangeable Shells for C18VE

## Exchangeable shells for C18VE

Shells are interchangeable and available in all widths. Rapid exchange with shell stand and pin exchange tool.

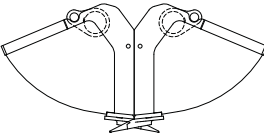
Type	Width (mm/in)	Opening (mm/in)	Height complete (mm/in)	Volume (liter/c.y.)	Number of teeth	Weight shells (kg/lbs)	Loading capacity (kg/lbs)	Closing force (kN/lbf)
<b>Clamshell Bucket</b>								
								
<b>C18VE-33S</b>	335 / 13.2	1655 / 65.2	1595 / 62.8	125 / 0.16	3	160 / 352	4500 / 9900	42 / 9240
<b>C18VE-40S</b>	400 / 15.8	1655 / 65.2	1595 / 62.8	160 / 0.21	3	180 / 396	4500 / 9900	42 / 9240
<b>C18VE-50S</b>	500 / 19.7	1655 / 65.2	1595 / 62.8	200 / 0.26	5	195 / 429	4500 / 9900	42 / 9240
<b>C18VE-60S</b>	600 / 23.6	1655 / 65.2	1595 / 62.8	245 / 0.32	5	225 / 495	4500 / 9900	42 / 9240
<b>C18VE-80S</b>	800 / 31.5	1655 / 65.2	1595 / 62.8	330 / 0.43	9	275 / 605	4500 / 9900	42 / 9240
<b>C18VE-100S</b>	1000 / 39.4	1655 / 65.2	1595 / 62.8	415 / 0.54	9	325 / 715	4500 / 9900	42 / 9240

## Excavating Grab

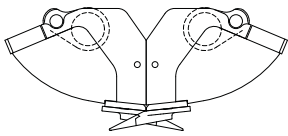

<b>C18VE-33S EG</b>	335 / 13.2	1205 / 47.4	1430 / 56.3	90 / 0.12	3	125 / 275	4500 / 9900	57 / 12540
<b>C18VE-40S EG</b>	400 / 15.8	1120 / 44.1	1385 / 54.5	55 / 0.07	3	130 / 286	4500 / 9900	60 / 13200
<b>C18VE-80S EG</b>	800 / 31.5	820 / 32.3	1380 / 54.3	100 / 0.13	9	185 / 407	4500 / 9900	69 / 15180

## Pipe Grab

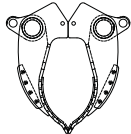

<b>C18VE-83S PG</b>	830 / 32.7	Ø100 - Ø 600/ Ø3.9 - Ø23.6	1625 / 64	Ø 600 mm/ Ø23.6		295* / 649	4500 / 9900	41 / 9020
---------------------	------------	-------------------------------	-----------	--------------------	--	------------	-------------	-----------

\*incl. support

## Well Shaft Grab



<b>C18VE-97S WSG</b>	Ø 970 / Ø38.2	970 / 38.2	1410 / 55.5	110 / 0.14	5	170 / 374	4500 / 9900	65 / 14300
----------------------	---------------	------------	-------------	------------	---	-----------	-------------	------------

note: larger shells available on request

## Hay and Forestry Grab

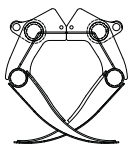

<b>A18VE-95S</b>	955 / 37.6	1830 / 72	1685 / 66.3	400 / 0.52		340 / 748	4500 / 9900	41 / 9020
<b>A18VE-122S</b>	1220 / 48	1835 / 72.2	1725 / 67.9	600 / 0.78		275 / 605	4500 / 9900	32 / 7040

## Rock Grab

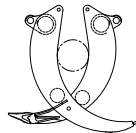

<b>R18VE-49S</b>	490 / 19.3	1850 / 72.8	1820 / 71.7	m <sup>2</sup> / cord 0,50 / 0.34		195 / 429	4500 / 9900	33 / 7260
------------------	------------	-------------	-------------	--------------------------------------	--	-----------	-------------	-----------

## Timber Grab

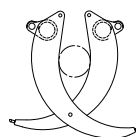

<b>T18VE-49S-0,5</b>	490 / 19.3	1830 / 72	1825 / 71.9	m <sup>2</sup> / cord 0,50 / 0.34		200 / 440	4500 / 9900	30 / 6600
<b>T18VE-49S-0,6</b>	490 / 19.3	1975 / 77.8	1905 / 75	0,60 / 0,40		220 / 484	4500 / 9900	33 / 7260

## Rail Tines

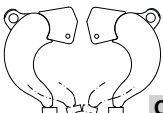

<b>C18VE-50S RG</b>	500 / 19.7	1250 / 49.2	1400 / 55.1	-		130 / 286	4500 / 9900	44 / 9680
---------------------	------------	-------------	-------------	---	--	-----------	-------------	-----------

**Package consists of:** shells, teeth (for clamshell bucket, excavating and well shaft grab), shell exchange aid kit and pin extraction tool

**Note:** special shells on request