

KM 507

Kwikbel™ and Striker

A simple, innovative and dependable system for changing lift connections. Consisting of two pieces - the Kwikbel™, which is welded onto a "target" (form basket, skid steer or gas bottle rack) and the Striker, which hangs from a hook.

- ▷ **Fast** - exchange attachments quickly as the self aligning Kwikbel™/Striker system needs no mechanical or hydraulical adjustments.
- ▷ **Economical** - the Kwikbel™/Striker system can be handled by the operator alone and no rotator hydraulics are necessary.
- ▷ **Safe** - direct contact with loads is eliminated which reduces finger pinch points; color coding allows operator to see work when fully extended.
- ▷ **Reliable** - sealed roller thrust bearing for free turning action.
- ▷ The Kwikbel™/Striker is suitable for loads up to 6500 lbs.

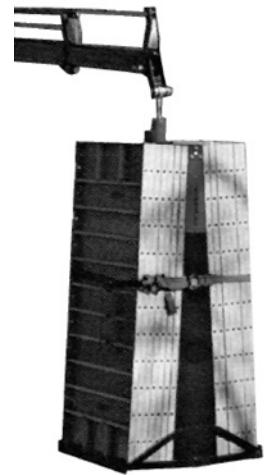

Form Crane Tool KM 507

Type	Description	Load capacity (lbs)	Self weight (lbs)
KM 507 01	Kwikbel™ - welded onto a 'target' (form basket, skid steer or gas bottle rack)	6500	12
KM 507 02	Striker - hangs from a non rotating hook	6500	7

Technical Details



Kwikbel™



Striker

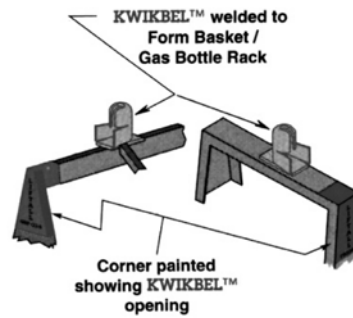

Painted corner showing Kwikbel™ opening

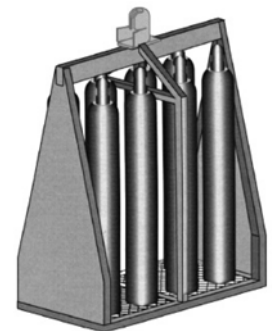

Kwikbel™ application at gas bottle rack

Accessories

Type	Description	Self weight (lbs)
KM 460 04 KM 04 S	non rotating hook	26

Technical Drawings

