

Rock grab with the low maintenance *HPXdrive* for compact excavators up to 6t/6600lbs and 9t/19800lbs operating weight to position natural rocks, curb stones etc.

- ▷ ***HPXdrive*** – the revolutionary concept for hydraulically operated grabs! The rotation of the arms of the grab is generated by two hollow shafts, which run opposed and have a helix thread, hydraulically driven by a single piston. **No hydraulic cylinder required!**
- ▷ **50% longer life cycle.** The drive unit runs in a permanent oil bath – no lubrication necessary. Resistant against dirt and blows, due to the compact design.
- ▷ **Constant closing force** during the entire operation.
- ▷ Different applications possible thanks to easy **shell exchange system**.



R08HPX

Rock Grabs R05HPX/ R08HPX

Type	Width	Volume	Opening	Height	Gripping range	Weight	Load capacity	Closing force	Operating weight
	E (mm/in)	(m ²)	A (mm/in)	C min. - max. (mm/in)	D min. (mm/in)				
R05HPX-0,16	405 /	0,16 /	1210 /	780 - 1000 /	170 /	220 /	1000 /	18 /	3-6 /
	15.9	0.11	47.6	30.7 - 39.3	6.6	484	2200	3960	6600-13200
R08HPX-0,16	405 /	0,16 /	1210 /	795 - 1005 /	170 /	230 /	1000 /	18 /	5-9 /
	15.9	0.11	47.6	31.2 - 39.6	6.6	506	2200	3960	11000-19800

Package consists of: rock grab, **KINSHOFER** rotator, hose guard and non-return valve

KINSHOFER Rotator

Integrated in a single unit with the *HPXdrive*, no more connecting hoses. Continuous rotation. Overload protection ensured by pressure relief valves.

Type	Upper dimension (width x pin-Ø) (mm/in)	Torque (Nm/ft.lbs)	Bending moment max. (Nm/ft.lbs)
R05HPX: KM 04 F140-30VE	84 x 30 / 3.3 x 1.1	850 / 630	3000 / 2215
R08HPX: KM 04 F140-30USE	84 x 30 / 3.3 x 1.1	1000 / 740	8500 / 6270

Accessories

Type	Description
KM 501 1t-8t	upper suspension without pendulum damper
KM 511 1t-8t	upper suspension with pendulum damper
KM 510 1t-8t	single pendulum damper to upgrade the upper suspension KM 501 1t-8t/2200-17600lbs
KSW03 cardanic	adapter for system L-Lock KMS03L/KHS03L incl. cardan link excl. pendulum damper – up to 6t/13200lbs
KSW03 cardanic-P	adapter for system L-Lock KMS03L/KHS03L incl. cardan link incl. pendulum damper – up to 6t/13200lbs
KSW08 cardanic	adapter for system L-Lock KMS08L/KHS08L incl. cardan link excl. pendulum damper – up to 12t/26400lbs
KSW08 cardanic-P	adapter for system L-Lock KMS08L/KHS08L incl. cardan link incl. pendulum damper – up to 12t/26400lbs
KM 685 06E hook set 2	adapters for quick change systems from other manufacturers or different sizes on request
	weld-on hooks (2 pcs.)

Requirements of carrier machine

Operating pressure at pump capacity (open/close):

26 MPa (260 bar) at max. 75 l/min / 3745 psi at max. 20 GPM

26 - 32 MPa (260 - 320 bar) at max. 40 l/min / 3745 - 4640 psi at max. 10.6 GPM

Operating pressure at pump capacity (rotate):

32 MPa (320 bar) at 15 - max. 50 l/min / 4640 psi at 4 - max. 13 GPM

Technical drawings

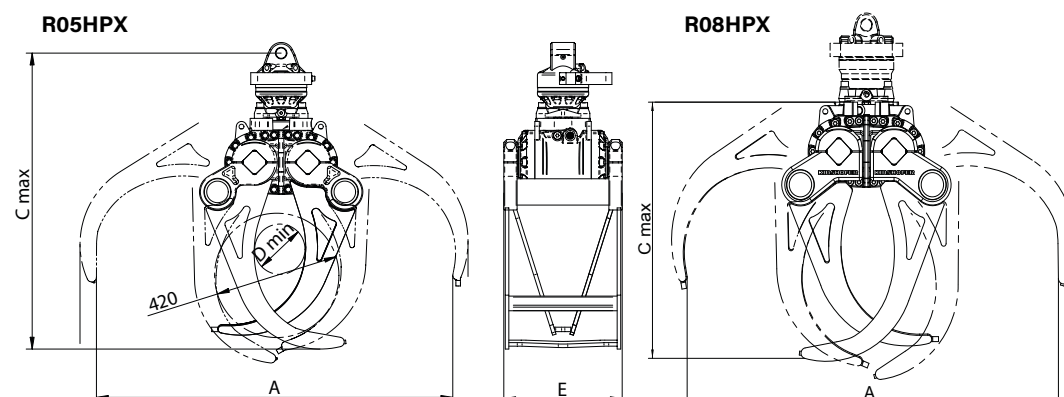

Free extension of warranty
kinshofer.com/service