

T06 - T09HPX-3Z 3-Finger Timber Grab with *HPXdrive* 3-9t / 6600-19800lbs

With the 3-finger timber grab for logging and forestry tasks with the low maintenance *HPXdrive* for excavators with up to 6t/13200lbs or 9t/19800lbs operating weight, even logs with only 90mm/3.5in diameter can be gripped firmly. Ideal also for the handling of brushwood and branches.

- ▷ ***HPXdrive*** – the revolutionary concept for hydraulically operated grabs! The rotation of the arms of the grab is generated by two hollow shafts, which run opposed and have a helix thread, hydraulically driven by a single piston. **No hydraulic cylinder required!**
- ▷ **50% longer life cycle.** The drive unit runs in a permanent oil bath – no lubrication necessary. Resistant against dirt and blows, due to the compact design.
- ▷ **Constant closing force** during the entire operation.
- ▷ Different applications possible thanks to easy **shell exchange system.**
- ▷ **Rigid mounting and flat 360° rotator for precise positioning.**
- ▷ **Arms made of cutting edge material 500HB.**



T09HPX-3Z

Timber Grab T06HPX/T09HPX

Type	Width E (mm/in)	Opening A (mm/in)	Height C max. (mm/in)	Gripping range D min. - D max. (Ø mm/in)	Weight (kg/lbs)	Load capacity (kg/lbs)	Closing force (kN/lbf)	Operating weight (t/lbs)
T06HPX-3Z	378 / 14.9	1240 / 48.8	1050 / 41.3	90 / 3.5 - 560 / 22	310 / 682	1000 / 2200	17 / 3740	3-6 / 6600-13200
T09HPX-3Z	375 / 14.7	1240 / 48.8	1035 / 40.7	90 / 3.5 - 560 / 22	320 / 704	2000 / 4400	17 / 3740	5-9 / 11000-19800

Package consists of: timber grab, **KINSHOFER** rotator (T06HPX: KM 10 F214/180 / T09HPX: KM 15 F273/273) and non-return valve

KINSHOFER Rotator

Integrated in a single unit with the *HPXdrive*, no more connecting hoses. Continuous rotation. Overload protection ensured by pressure relief valves.

Type	Upper dimension (hole/Ø-hole pattern) (mm/in)	Torque (Nm/ft.lbs)	Bending moment max. (Nm/ft.lbs)
T06HPX: KM 10 F214/180	6 x M16; Ø 180 / 7	1000 / 737	12000 / 8850
T09HPX: KM 15 F273/273	10 x M16; Ø 273 / 10.7	2000 / 1475	50000 / 36875

Accessories

Type	Description
KM 691 8t	adapter plate for specific solutions – up to 8t/17600lbs
KM 690 8t	adapter for rigid mounting – up to 8t/17600lbs
OQ45/4 rigid	bolt-on adapter for Oilquick OQ45 - up to 12t/26400lbs
KSW03 rigid	bolt-on adapter for system L-Lock KMS03L/KHS03L for rigid mounting – up to 6t/13200lbs
KSW08 rigid	bolt-on adapter for system L-Lock KMS08L/KHS08L for rigid mounting – up to 12t/26400lbs
KM 980-2 2t-8t c	adapters for quick change systems from other manufacturers or different sizes on request
	solenoid valve for additional circuit, up to 26MPa/3770psi, incl. parts and mounting

Requirements of carrier machine

Operating pressure at pump capacity (open/close):

26 MPa (260 bar) at max. 75 l/min / 3745 psi at max. 20 GPM
 26 - 32 MPa (260 - 320 bar) at max. 40 l/min / 3745 - 4640 psi at max. 10.6 GPM

Operating pressure at pump capacity (rotate):

32 MPa (320 bar) at 20 - 50 l/min / 4640 psi at 5.3 - 13 GPM

Technical drawings

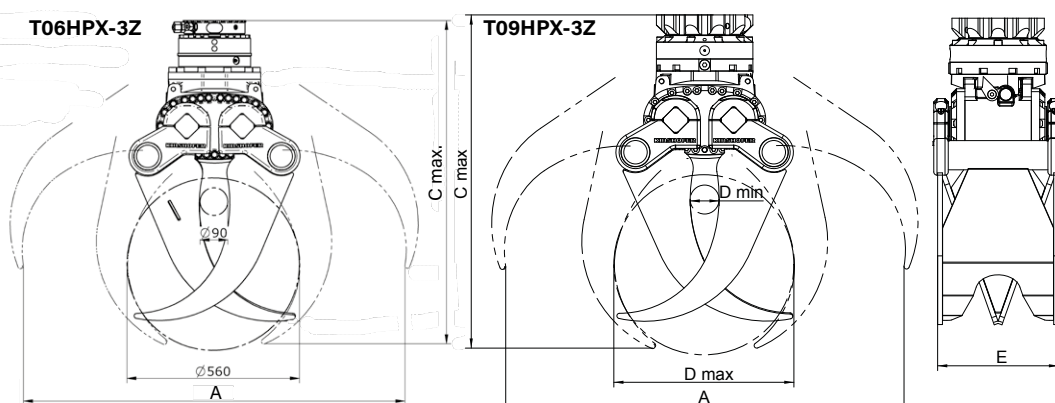

Free extension of warranty
kinshofer.com/service