



NEWS
Special and Custom
Solutions

Wood Chips Grapple KM 602 Special



www.kinshofer.com



193110/2009

The new wood chips grapple KM 602 Special is a combination of the already proven high volume clamshell bucket KM 602 and the robust logging grapple KM 634 - the ideal tool for loading and handling wood chips or light bulk cargo.

The grapple has a big volume while having a low self weight.

The mounted rotator with 6t loading capacity allows for a precise positioning of the load and is equipped additionally with a hose protection.

An integrated **counter-balance valve** guarantees a secure retention of loads and thus increases the working security.



TECHNICAL DATA:

Operating pressure:	240 bar
Internal pressure:	240 bar
Pump capacity:	40 - 75 l/min
Load capacity:	2000 kg
Closing force:	23 kN
Volume:	1500 l
Self weight:	550 kg

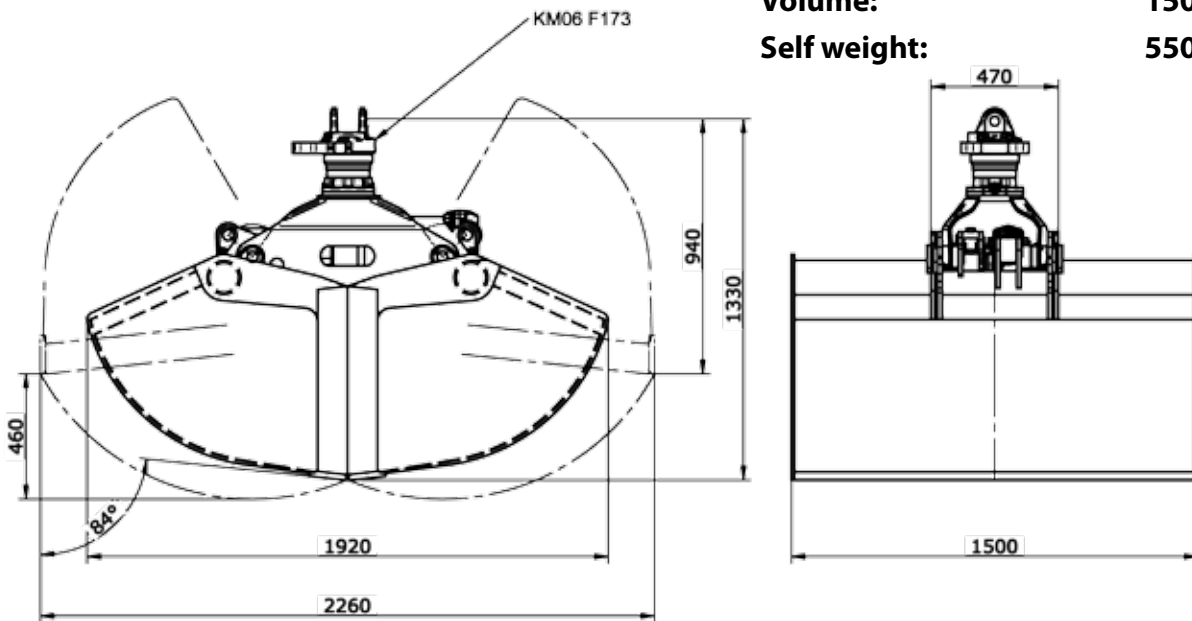

More special and custom solutions can be found on our website under „Downloads“, „Products“ or the Product News Archive.

You also have the possibility to apply for our newsletter on our website under „Service“.

We reserve the right to amend specifications without prior notice! **KINSHOFER** GmbH, D- 83666 Waakirchen, Germany

Main Office Germany:
KINSHOFER GmbH
 Hauptstrasse 76
 83666 Waakirchen
 Tel.: +49 (0)8021 – 88 99 0
 Fax: +49 (0)8021 – 88 99 37
 Email: info@kinshofer.com

France:
KINSHOFER France S.A.R.L.
 B.P. 20100
 67213 Obernai Cedex
 Tel.: +33 (0) 3 88 39 55 00
 Fax: +33 (0) 3 88 79 06 75
 Email: info@kinshofer.fr

General Agency for Benelux:
 Rigter Handelsonderneming B.V.
 Nieuwe Maatsweg 7
 NL-3755 NP Eemnes
 Tel.: +31 (0) 35 53 10628
 Fax: +31 (0) 35 53 17462
 Mobil: +31 (0) 653 - 370935
 +31 (0) 651 - 366420
 Email: gf.rigter@gmail.com gfjm.rigter@hccnet.nl

United Kingdom:
KINSHOFER UK Ltd.
 4 Milton Industrial Court
 Horsfield Way, Bredbury
 Stockport, Cheshire, SK6 2TA
 Tel.: +44 (0)161 – 406 7046
 Fax: +44 (0)161 – 406 7014
 Email: sales@kinshofer.co.uk

... everywhere in front

KINSHOFER
 crane and excavator attachments